



Design & Installation Engineering Guide

2023
© Copyright Pexgol

PEXGOL
X-LINKED PIPING SOLUTIONS

For infrastructure & industrial piping systems

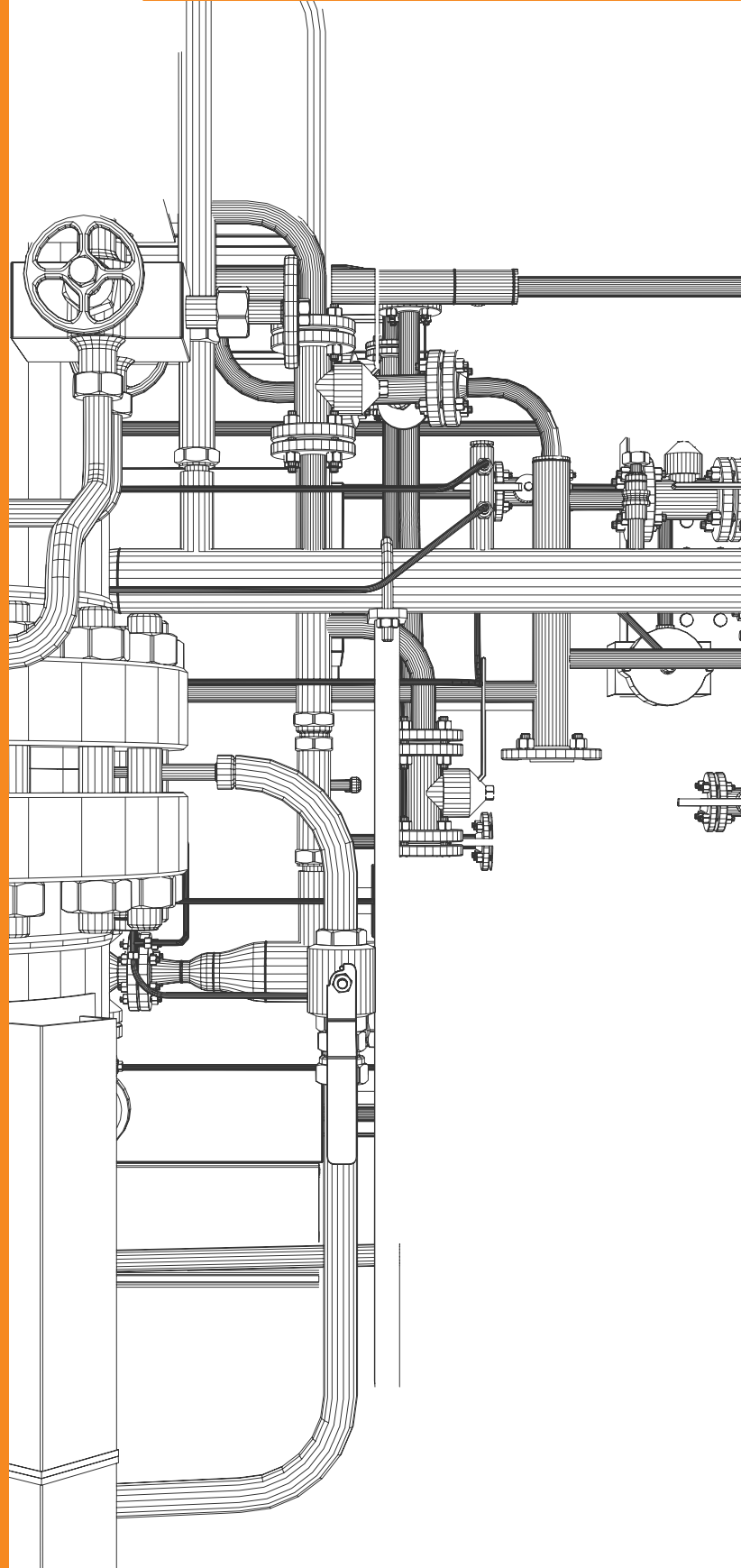

Golan Plastic Products, manufacturer and distributor of Pexgol, is a world leader in providing comprehensive solutions for the transportation of all types of hot, corrosive or abrasive liquid materials. It is the only manufacturer on an international scale with factories in Israel, Argentina, Chile and Mexico, specialising in large diameter, cross-linked polyethylene pipe systems, the most cost-effective, long-term solutions available to infrastructure, industrial, oil & gas and mining sectors throughout the world.

Established in 1964, **Golan Plastic Products** today is a global company listed on the Tel Aviv stock exchange.

Pexgol's global reputation and reliable brand name are based on accredited international standards in more than 40 countries, along with a decades-long proven track record with established clients around the world.

Welcome



Pexgol Solutions

Technical Information

Fittings

Design Considerations

Installation Instructions

Transportation of Pexgol Pipes

Application Questionnaire

Fittings Catalogue

Index

/ 1

Technical Information

Design Stresses of Pexgol Pipes8
Allowable Working Pressures (bar/psi)9
Dimensions & Pressure Rating10
Flow Chart for Full Flow Conditions14
Coefficients of Friction23
Pexgol Properties24
Chemical Resistance26

/ 2

Design Considerations

Water Hammer44
Water Hammer Calculation for Different Pipe Materials45
Natural Bend Radius in Pexgol Pipes49
Natural Bend in Pexgol Pipes50
Vacuum/Suction Pipelines51
Pexgol Pipes Design Considerations52
Slurry Design Considerations53
Inclined and Dewatering Pipes, High Gradient Supply Lines54
Design Guidelines for Complete Systems58
Design Considerations for Pexgol Fittings60
Abrasion Resistance63

/ 3

Installation Instructions

Performing Pressure Tests in Pexgol Water Supply Lines & Dewatering66
Instructions for Welding EF Fittings67
Electrofusion Welding69
Saddle Welding71
Installation of Mechanical Branch Saddles72
Connecting Pexgol Pipes with Flared Ends73
Repair Instructions for Pexgol Pipes74
Guidelines for Underground Installations75
Backfilling of the Trench75
Above-Ground Installation Guidelines76
Calculation of Fores at Fixpoints77
Pexgol Horizontally Supported Pipeline80

/ 4

Pexgol Solutions

Industry

Dewatering Lines84
Borehole Rising Mains84
Industrial Installation Example85
Industrial Applications85

Infrastructure

Infrastructure Applications86
Pexgol Cold Water Supply Installation Guide86
Pexgol Lines for Very Low Ambient Temperatures86
Pexgol Fire Extinguisher Lines86
Natural Gas Pipes86
Air Supply Pressure Lines86
Pexgol Pre-Insulated Pipes.....87

Residential

Pexgol Solutions for Hot and Cold Water88
Hot Water Risers89

/ 5

Transportation of Pexgol Pipes

Transportation of Pexgol Pipes in Coils	92
Transportation of Pexgol Pipes in Coils with Cores	95
Transportation of Pexgol Pipes in Straight Sections	95

/ 6

Application Questionnaire

Newtonian Fluids	98
Boreholes & Dewatering.....	98
Slurry	99
Conversion Tables	100

/ 7

Fittings

Non-Restrained Fittings and Pullout Prevention Techniques	104
Fixpoint Clamp	105
Floating Fixpoint Devices	106
PE100 Electrofusion Fittings	107
Reinforced Electrofusion Couplers	108
PE-Xc Fittings	109
PE-X Lined Fittings	110
Brass Fittings for Pexgol Pipes Class 15 & 24	115
Branch-Off Saddles	116
PE-Xa Pexgol Elbows	117
PE-Xa Flared End Connectors	119
Compatibility of Pexgol Flanges	121
PE-Xa Short Sections with Two Flared Ends	122
PE-Xa Spigot Reducers	123
Pexgol Reducers with Flared Ends and Flanges	125
PE-Xc ID Adaptor/Spacer	125
Pexgol Instrument Tees & Water Flushing Ports	126
Pexgol Transition Flange	126
Flange Couplers for Pexgol Pipes	127
Fixpoint Clamps	131
Fixpoint Bridge	134

/ 8

Fittings Catalogue

Flared Ends/Stub Ends	138
Loose Flanges	139
Split Flanges for Flared Ends	140
Split Flanges for PE-Xc Fittings	141
Pexgol Elbow	142
Pexgol Reducer	145
Flange Coupler	147
Hydrant Connector	150
Branch-Off Saddles - Flanged Outlet	151
Branch-Off Saddles - Female Flanged Outlet	153
Brass Fittings	154
GP Bolt Connector Stainless Steel	158
Fixpoint Clamps	159
Fixpoint Bridge	160
PE-X Lined Fittings	161
Mechanical Double Connector	173





1

Technical Information





Index

Design Stresses of Pexgol Pipes

Allowable Working Pressures (bar/
psi)

Dimensions & Pressure Rating

Flow Chart for Full Flow Conditions

Coefficients of Friction

Pexgol Properties

Chemical Resistance

Design Stresses of Pexgol Pipes

Pexgol pipes are produced according to the DIN Standards 16892/16893 and the Israeli Standard 1519 Part 1. These standards show the working pressures of Pexgol pipes at various temperatures.

Pipes according to other standards (IPS according to ASTM 2788, for example), are available by special order.

The working pressures for Pexgol pipes are determined by the following equation:

$$p = \frac{2\sigma t}{D-t} \quad \text{or} \quad p = \frac{2\sigma}{\text{SDR}-1} \quad \text{or} \quad \frac{\sigma}{S}$$

P = Maximum working pressure (kg/cm²)

σ = Long term strength at the design temperature (kg/cm²) (10.1)

D = Outside diameter (mm)

t = Wall thickness (mm)

S = ISO 4065 series

SDR (Standard Dimensions Ratio) = $\frac{D}{t} = 2s + 1$

Table 8.1: Changes of Design Stress Values σ with Temperature

Temperature (°C)	σ (kg/cm ²)
10°C	85
20°C	76
30°C	66.5
40°C	59
50°C	52.5
60°C	48
70°C	42.5
80°C	37.5
90°C	33.5
95°C	32
100°C	27.5
105°C	22.5
110°C	18.75

Allowable Working Pressures

The working pressures of Pexgol pipes are based on DIN 16893-2000 and the accumulated experience of Pexgol pipes in Infrastructure and Industry including pipes that were installed since 1985 at the Dead Sea Hot Leach Crystallisation Facility carrying hot sylvinit at 114°C and are still working today.

The design stresses σ in tables 8.1 and the working pressures in tables 9.1 & 9.2 were calculated with a safety factor of 1.25 according to DIN 16893-2000 these values are for water.

In case of chemicals and corrosive agents, the working pressures might have to be de-rated according to the data in the chemical resistance tables.

Allowable Working Pressures

Table 9.1: Allowable working pressures [bar] for conveying water in Pexgol pipes, with a safety factor C = 1.25

Design Temperature	Class 6	Class 8	Class 10	Class 12	Class 15	Class 19	Class 24	Class 30
	Pipe Series (S)							
	12.5	10	7.6	6.3	5	4	3.2	2.5
	Standard Dimension Ratio (SDR)							
	26	21	16.2	13.6	11	9	7.4	6
10 °	6.8	8.5	11.20	13.50	17.00	21.40	26.90	33.89
20 °	6.0	7.6	9.90	11.90	15.00	18.90	23.80	29.99
30 °	5.3	6.7	8.80	10.60	13.30	16.80	21.10	26.59
40 °	4.7	5.9	7.80	9.40	11.80	14.90	18.70	23.56
50 °	4.1	5.2	7.00	8.30	10.50	13.20	16.70	21.04
60 °	3.8	4.8	6.30	7.50	9.50	11.90	15.00	18.90
70 °	3.4	4.3	5.60	6.70	8.50	10.70	13.40	16.88
80 °	3.0	3.8	5.10	6.10	7.50	9.50	12.00	15.12
90 °	2.7	3.4	4.50	5.40	6.80	8.60	10.90	13.73
95 °	2.6	3.2	4.10	4.90	6.40	8.10	10.30	12.98
100 °	2.1	2.7	3.5	4.2	5.5	7.0	9.0	11.2
105 °	1.8	2.2	2.8	3.4	4.5	5.5	7.0	8.7
110 °	1.5	1.9	2.40	2.90	3.80	4.70	5.90	7.43

Table 9.2: Allowable working pressures [psi] for conveying water in Pexgol pipes, with a design factor DF = 0.8; safety factor C = 1.25

Design Temperature		Class 6	Class 8	Class 10	Class 12	Class 15	Class 19	Class 24	Class 30
		12.5	10	7.6	6.3	5	4	3.2	2.5
°C	°F	26	21	16.2	13.6	11	9	7.4	6
10	50	99	123	162	196	247	310	390	491
21	70	83	105	137	164	207	261	329	414
32	90	72	91	120	144	181	228	287	361
38	100	72	90	119	143	180	227	285	360
49	120	61	77	104	123	155	195	247	311
60	140	55	70	91	109	138	173	218	274
71	160	49	61	80	96	122	153	192	241
82	180	42	54	72	86	106	134	170	214
88	190	40	50	67	80	101	128	162	204
93	200	39	47	61	73	95	120	153	192
99	210	31	40	51	62	81	103	132	164
104,5	220	26	32	41	50	66	81	102	127
110	230	22	28	35	42	55	68	86	108

Dimensions & Pressure Rating



Pexgol pipes are transported in coils, coils with cores and straight sections. See "Transportation" section.

Pexgol Pipe Class 6 (SDR 26 S12.5): Working pressures: 6 bar at 20°C, Initial ring stiffness 5 KN/m²

Catalogue Number	Outside Diameter (mm)	Wall thickness (mm)	Inside Diameter (mm)	Weight (kg/m)
PA-903.5 BLK	90	3.5	83	0.9
PA-1104.2 BLK	110	4.2	101.6	1.4
PA-1254.8 BLK	125	4.8	115.4	1.8
PA-1405.4 BLK	140	5.4	129.2	2.3
PA-1606.2 BLK	160	6.2	147.6	3
PA-1806.9 BLK	180	6.9	166.2	3.7
PA-2007.7 BLK	200	7.7	184.6	4.6
PA-2258.6 BLK	225	8.6	207.8	5.8
PA-2509.6 BLK	250	9.6	230.8	7.2
PA-28010.7 BLK*	280	10.7	258.6	9
PA-31512.1 BLK*	315	12.1	290.8	11.4
PA-35513.6 BLK	355	13.6	327.8	14.4
PA-40015.3 BLK*	400	15.3	369.4	18.3
PA-45017.2 BLK	450	17.2	415.6	23.2
PA-50019.1 BLK*	500	19.1	461.8	28.6
PA-56021.4 BLK**	560	21.4	517.2	35.8
PA-63024.1 BLK*	630	24.1	581.8	45.4
PA-71027.2 BLK**	710	27.2	655.6	57.8

Pexgol Pipe Class 8 (SDR 21 S10): Working pressures: 7.6 bar at 20°C, Initial ring stiffness 10 KN/m²

Catalogue Number	Outside Diameter (mm)	Wall thickness (mm)	Inside Diameter (mm)	Weight (kg/m)
PA-753.6BLK	75	3.6	67.8	0.8
PA-904.3BLK	90	4.3	81.4	1.1
PA-1105.3BLK	110	5.3	99.4	1.7
PA-1256.0BLK	125	6	113	2.2
PA-1406.7BLK	140	6.7	126.6	2.8
PA-1607.7BLK	160	7.7	144.6	3.6
PA-1808.6BLK	180	8.6	162.8	4.6
PA-2009.6BLK	200	9.6	180.8	5.7
PA-22510.8BLK	225	10.8	203.4	7.2
PA-25011.9BLK	250	11.9	226.2	8.8
PA-28013.4BLK*	280	13.4	253.2	11.1
PA-31515.0BLK*	315	15	285	14
PA-35516.9BLK	355	16.9	321.2	17.8
PA-40019.1BLK*	400	19.1	361.8	22.6
PA-45021.5BLK*	450	21.5	407	28.7
PA-50023.9BLK	500	23.9	452.2	35.4
PA-56026.7BLK**	560	26.7	506.6	44.3
PA-63030.0BLK*	630	30	570	56
PA-71033.8BLK**	710	33.8	642.4	71.1

* Minimum quantity required ** By special order

Pexgol Pipe Class 10 (SDR 16.2 S7.6): Working pressures: 10 bar at 20°C, 6 bar for natural gas | Initial ring stiffness 23 KN/m²

Catalogue Number	Outside Diameter (mm)	Wall thickness (mm)	Inside Diameter (mm)	Weight (kg/m)
PA-633.9BLK	63	3.9	55.2	0.72
PA-754.7BLK	75	4.7	65.8	1.03
PA-905.6BLK	90	5.6	78.8	1.47
PA-1106.8BLK	110	6.8	96.4	2.18
PA-1257.7BLK	125	7.7	109.6	2.81
PA-1408.7BLK	140	8.7	122.6	3.55
PA-1609.9BLK	160	9.9	140.2	4.62
PA-18011.1BLK	180	11.1	157.8	5.83
PA-20012.4BLK	200	12.4	175.2	7.23
PA-22513.9BLK	225	13.9	197.2	9.12
PA-25015.5BLK	250	15.5	219	11.30
PA-28017.3BLK	280	17.3	245.4	14.12
PA-31519.5BLK	315	19.5	276	17.91
PA-35521.9BLK	355	21.9	311.2	22.67
PA-40024.7BLK	400	24.7	350.6	28.81
PA-45027.8BLK	450	27.8	394.4	36.48
PA-50030.9BLK	500	30.9	438.2	45.05
PA-56034.6BLK**	560	34.6	490.8	53.6
PA-63038.9BLK	630	38.9	552.2	71.50
PA-71043.8BLK**	710	43.8	622.4	90.75

Pexgol Pipe Class 12 (SDR 13.6 S6.3): Working pressures: 12 bar at 20°C, 7.5 bar for natural gas | Initial ring stiffness 40 KN/m²

Catalogue Number	Outside Diameter (mm)	Wall thickness (mm)	Inside Diameter (mm)	Weight (kg/m)
PA-634.7BLK	63	4.7	53.6	0.85
PA-755.6BLK	75	5.6	63.8	1.21
PA-906.7BLK	90	6.7	76.6	1.73
PA-1108.1BLK	110	8.1	93.8	2.57
PA-1259.2BLK	125	9.2	106.6	3.31
PA-14010.3BLK	140	10.3	119.4	4.15
PA-16011.8BLK	160	11.8	136.4	5.43
PA-18013.3BLK	180	13.3	153.4	6.8
PA-20014.7BLK	200	14.7	170.6	8.47
PA-22516.6BLK	225	16.6	191.8	10.75
PA-25018.4BLK	250	18.4	213.2	13.42
PA-28020.6BLK	280	20.6	238.8	16.60
PA-31523.2BLK	315	23.2	268.6	21.04
PA-35526.1BLK	355	26.1	302.8	26.68
PA-40029.4BLK	400	29.4	341.2	33.86
PA-45033.1BLK	450	33.1	383.8	42.89
PA-50036.7BLK	500	36.7	426.4	52.85
PA-56041.2BLK**	560	41.2	477.6	66.50
PA-63046.6BLK*	630	46.6	537.4	84.60
PA-71052.2BLK**	710	52.2	605.6	106.8

* Minimum quantity required ** By special order

Pexgol Pipe Class 15 (SDR 11 S5): Working pressures: 15 bar at 20°C, 9 bar for natural gas | Initial ring stiffness 80 KN/m²

Catalogue Number	Outside Diameter (mm)	Wall thickness (mm)	Inside Diameter (mm)	Weight (kg/m)
PA-162BLK	16	2.0	13	0.09
PA-202BLK	20	2.0	16.2	0.11
PA-252.3BLK	25	2.3	20.4	0.16
PA-322.9BLK	32	2.9	26.2	0.26
PA-403.7BLK	40	3.7	32.6	0.42
PA-504.6BLK	50	4.6	40.8	0.65
PA-635.8BLK	63	5.8	51.4	1.03
PA-756.8BLK	75	6.8	61.4	1.44
PA-908.2BLK	90	8.2	73.6	2.09
PA-11010BLK	110	10.0	90	3.11
PA-12511.4BLK	125	11.4	102.2	4.03
PA-14012.7BLK	140	12.7	114.6	5.02
PA-16014.6BLK	160	14.6	130.8	6.60
PA-18016.4BLK	180	16.4	147.2	8.34
PA-20018.1BLK	200	18.1	163.8	10.23
PA-22520.4BLK	225	20.4	184.2	12.97
PA-25022.7BLK	250	22.7	204.6	16.05
PA-28025.4BLK	280	25.4	229.2	20.10
PA-31528.6BLK	315	28.6	257.8	25.46
PA-35532.2BLK	355	32.2	290.6	32.30
PA-40036.3BLK*	400	36.3	327.4	41.5
PA-45040.9BLK*	450	40.9	368.2	52
PA-50045.4BLK	500	45.4	409.2	65
PA-56050.9BLK**	560	50.9	458.4	82
PA-63057.3BLK	630	57.3	515.6	103
PA-71064.5BLK**	710	64.5	581	129.50

Pexgol Pipe Class 19 (SDR 9 S4): Working pressures: 19 bar at 20°C, 11.5 bar for natural gas | Initial ring stiffness 150 KN/m²

Catalogue Number	Outside Diameter (mm)	Wall thickness (mm)	Inside Diameter (mm)	Weight (kg/m)
PA-637.1BLK	63	7.1	48.8	1.25
PA-758.4BLK	75	8.4	58.2	1.75
PA-9010.1BLK	90	10.1	69.8	2.50
PA-11012.3BLK	110	12.3	85.4	3.75
PA-12514.1BLK	125	14.1	97	4.90
PA-14015.7BLK	140	15.7	108.6	6.10
PA-16017.9BLK	160	17.9	124.2	7.90
PA-18020.1BLK	180	20.1	139.8	9.9
PA-20022.4BLK	200	22.4	155.2	12.40
PA-22525.0BLK	225	25.2	175	15.55
PA-25027.9BLK	250	27.9	194.2	19.30
PA-28031.3BLK*	280	31.3	217.4	24.20
PA-31535.2BLK	315	35.2	244.6	30.65
PA-35539.7BLK	355	39.7	275.6	39
PA-40044.7BLK*	400	44.7	310.6	49.40
PA-45050.3BLK	450	50.3	349.4	62.50
PA-50055.8BLK*	500	55.8	388.4	77
PA-56062.5BLK**	560	62.5	435	96.70
PA-63070.0BLK*	630	70.0	489.4	122
PA-71078.9BLK**	710	78.9	552.2	154.9

* Minimum quantity required ** By special order

Pexgol Pipe Class 24 (SDR 7.4 S3.2): Working pressures: 24 bar at 20°C, 15 bar for natural gas | Initial ring stiffness 300 KN/m²

Catalogue Number	Outside Diameter (mm)	Wall thickness (mm)	Inside Diameter (mm)	Weight (kg/m)
PA-122N	12	2.0	8	0.06
PA-162.2BLK	16	2.2	11.6	0.09
PA-202.8BLK	20	2.8	14.4	0.15
PA-253.5BLK	25	3.5	18	0.23
PA-324.4BLK	32	4.4	23.2	0.38
PA-405.5BLK	40	5.5	29	0.59
PA-506.9BLK	50	6.9	38.2	0.92
PA-638.6BLK	63	8.6	45.8	1.45
PA-7510.3BLK	75	10.3	54.4	2.07
PA-9012.3BLK	90	12.3	65.4	2.97
PA-11015.1BLK	110	15.1	79.8	4.45
PA-12517.1BLK	125	17.1	90.8	5.73
PA-14019.2BLK	140	19.2	101.6	7.21
PA-16021.9BLK	160	21.9	116.2	9.40
PA-18024.6BLK	180	24.6	130.8	11.88
PA-20027.4BLK	200	27.3	145.2	14.65
PA-22530.7BLK	225	30.8	163.4	18.59
PA-25034.2BLK	250	34.2	181.6	23
PA-28038.3BLK	280	38.3	203.4	29
PA-31543.1BLK*	315	43.1	228.8	37
PA-35548.5BLK	355	48.5	258	47
PA-40054.7BLK*	400	54.7	290.6	59
PA-45061.5BLK*	450	61.5	327	75
PA-50068.5BLK*	500	68.5	363	93
PA-56076.7BLK**	560	76.7	406.5	117
PA-63086.3BLK*	630	86.3	457	148
PA-71097.3BLK**	710	97.3	515	185.4

Pexgol Pipe Class 30 (SDR 6 S2.5): Working pressures: 30 bar at 20°C, 12.5 bar at 95°C, 19 bar for natural gas | Initial ring stiffness 640 KN/m²

Catalogue Number	Outside Diameter (mm)	Wall thickness (mm)	Inside Diameter (mm)	Weight (kg/m)
PA-6310.5BLK	63	10.5	42	1.7
PA-7512.5BLK	75	12.5	50	2.4
PA-9015BLK	90	15	60	3.5
PA-11018.3BLK	110	18.3	73	5.2
PA-12520.8BLK	125	20.8	83.4	6.8
PA-14023.3BLK	140	23.3	93	8.5
PA-16026.6BLK	160	26.6	106.8	11
PA-18029.9BLK	180	29.9	120	14
PA-20033.2BLK	200	33.2	133.5	17.2
PA-22537.4BLK	225	37.4	150	22
PA-25041.5BLK	250	41.5	167	27
PA-28046.5BLK*	280	46.5	187	34
PA-31552.3BLK*	315	52.3	210	43
PA-35559BLK*	355	59	237	55
PA-40066.7BLK*	400	66.7	266.5	70
PA-45075BLK*	450	75	300	89
PA-50083.4BLK*	500	83.5	333	108.5
PA-56093.4BLK**	560	93.5	373	135.5
PA-630105BLK*	630	105	420	171.5
PA-710118.3BLK**	710	118.3	473	217.7

* Minimum quantity required ** By special order

Flow Chart for Full Flow Conditions (Water)

Chart 15.1: Class 6 (SDR 26)

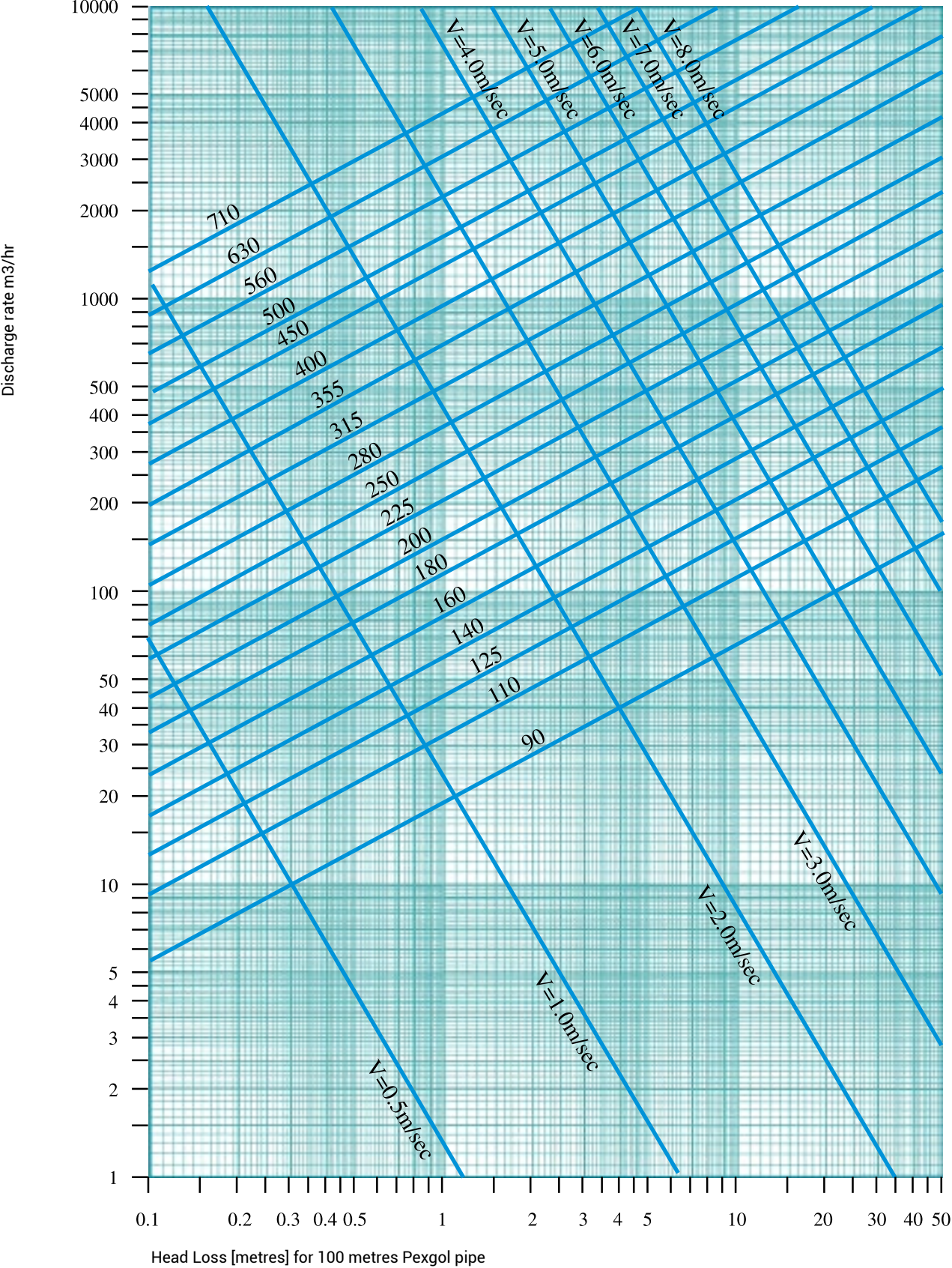

2023

Technical information

Chart 16.1 Class 8 (SDR 21)

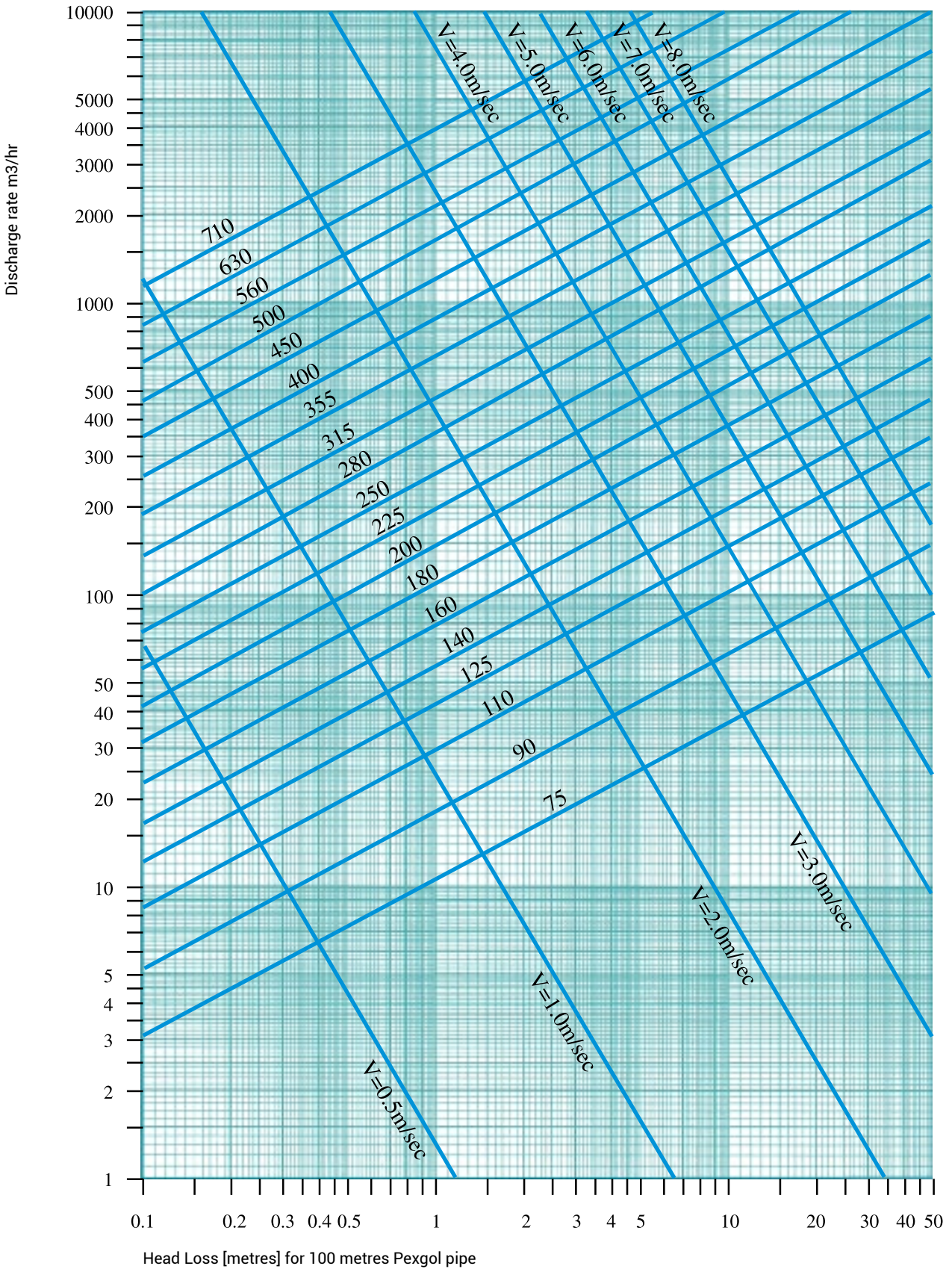
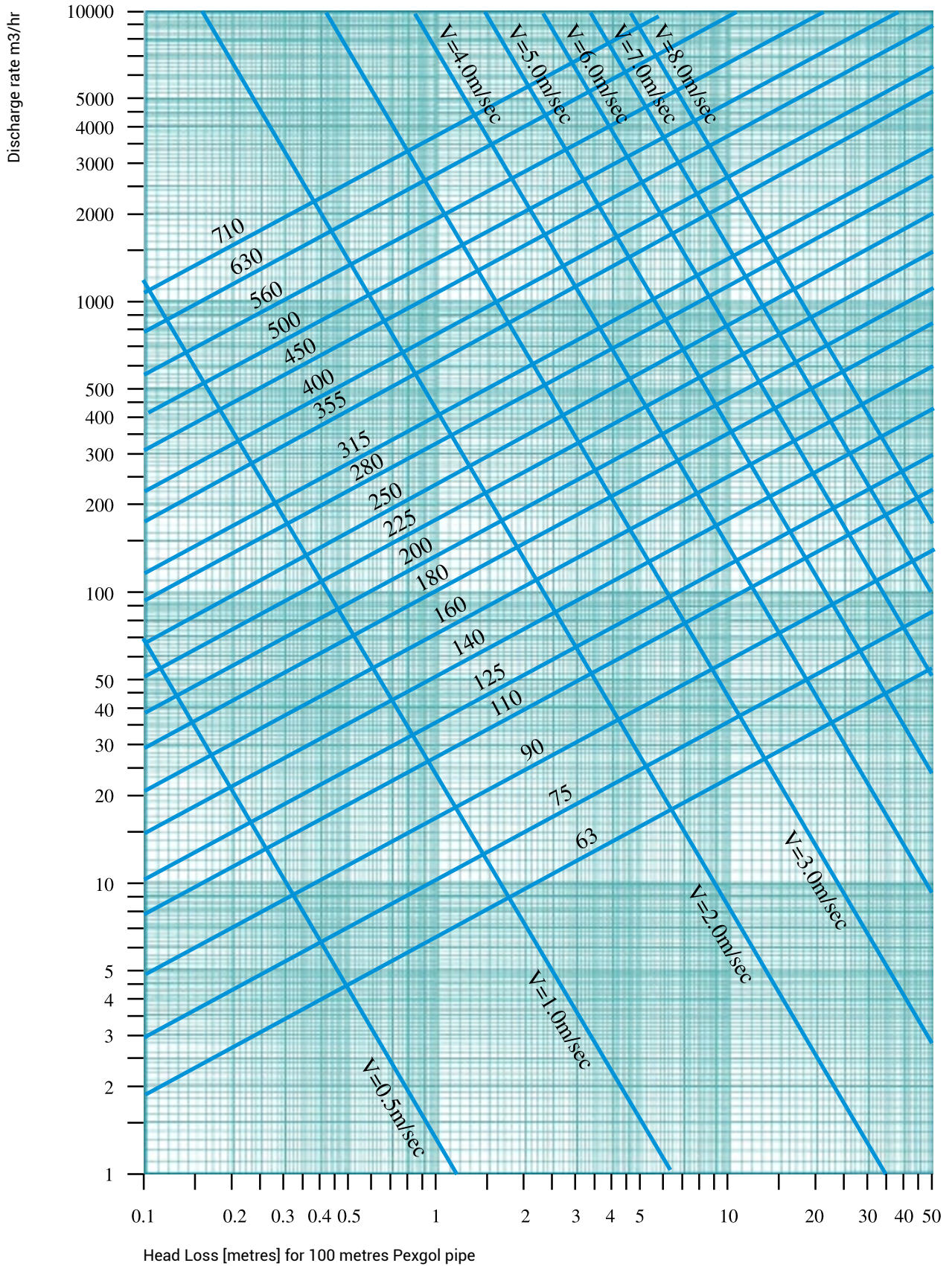

Chart 17.1 Class 10 (SDR 16.2)



2023

Technical information

Chart 18.1 Class 12 (SDR 13.6)

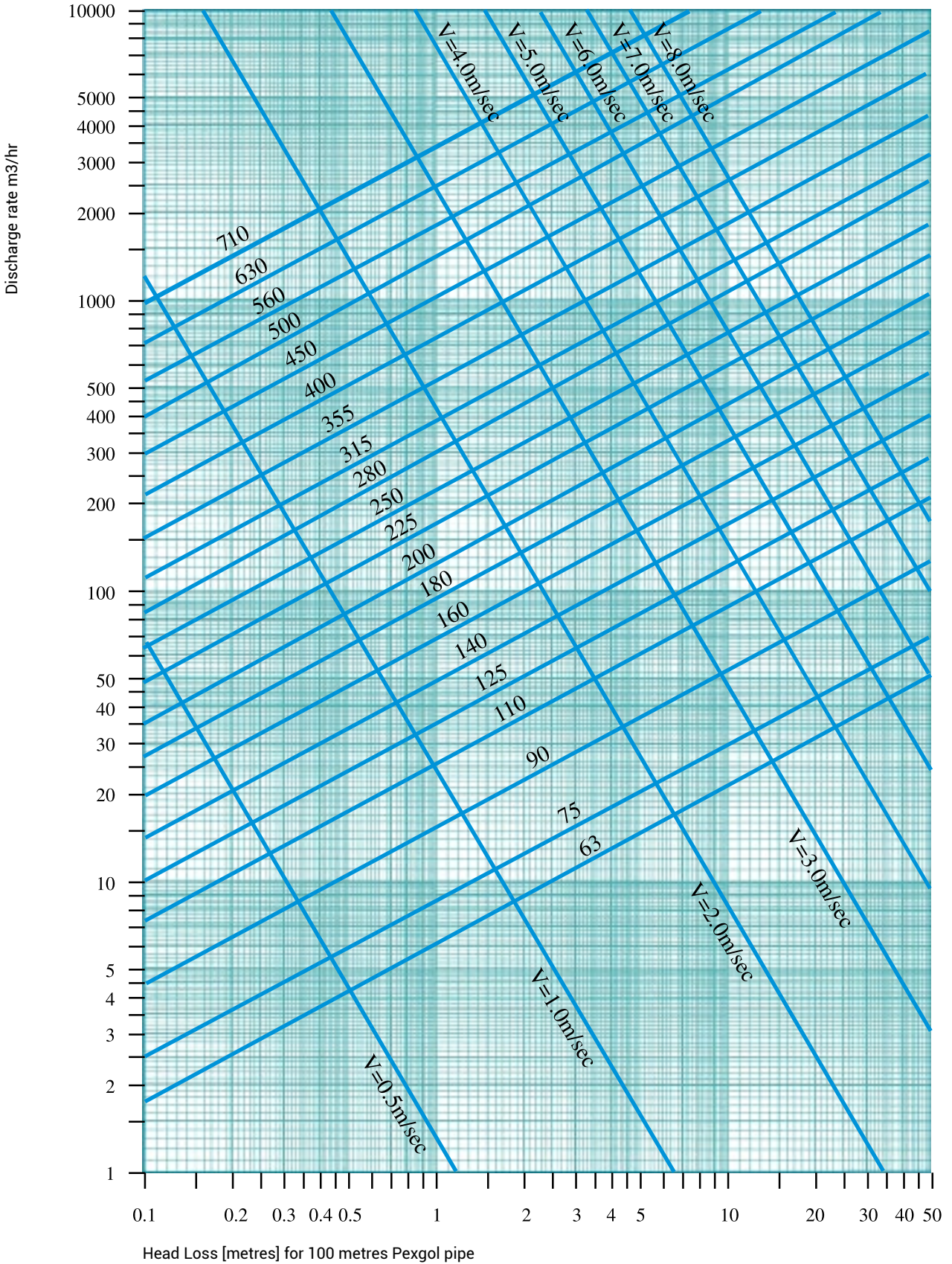
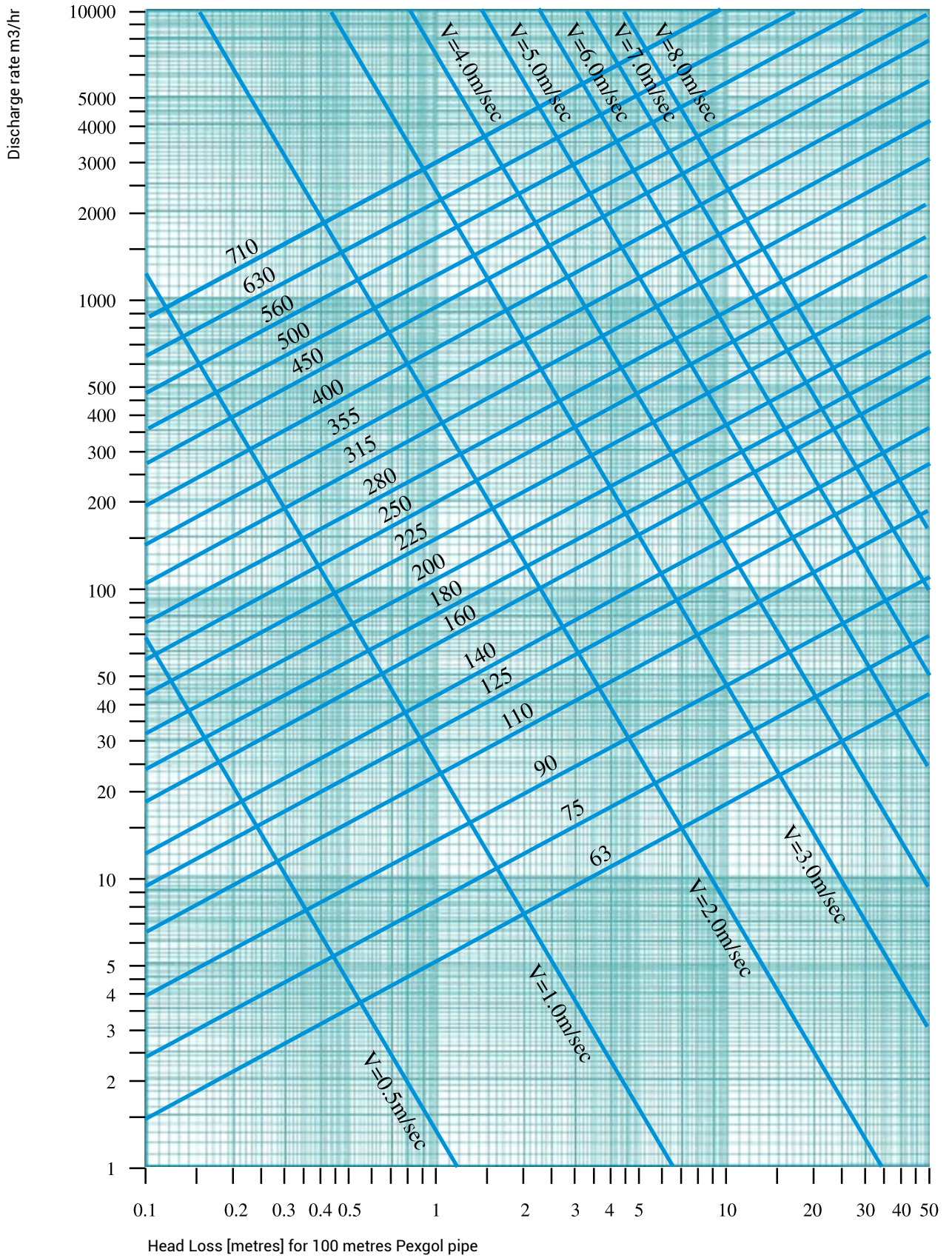

Chart 19.1 Class 15 (SDR 11)



2023

Technical Information

Chart 20.1 Class 19 (SDR 9)

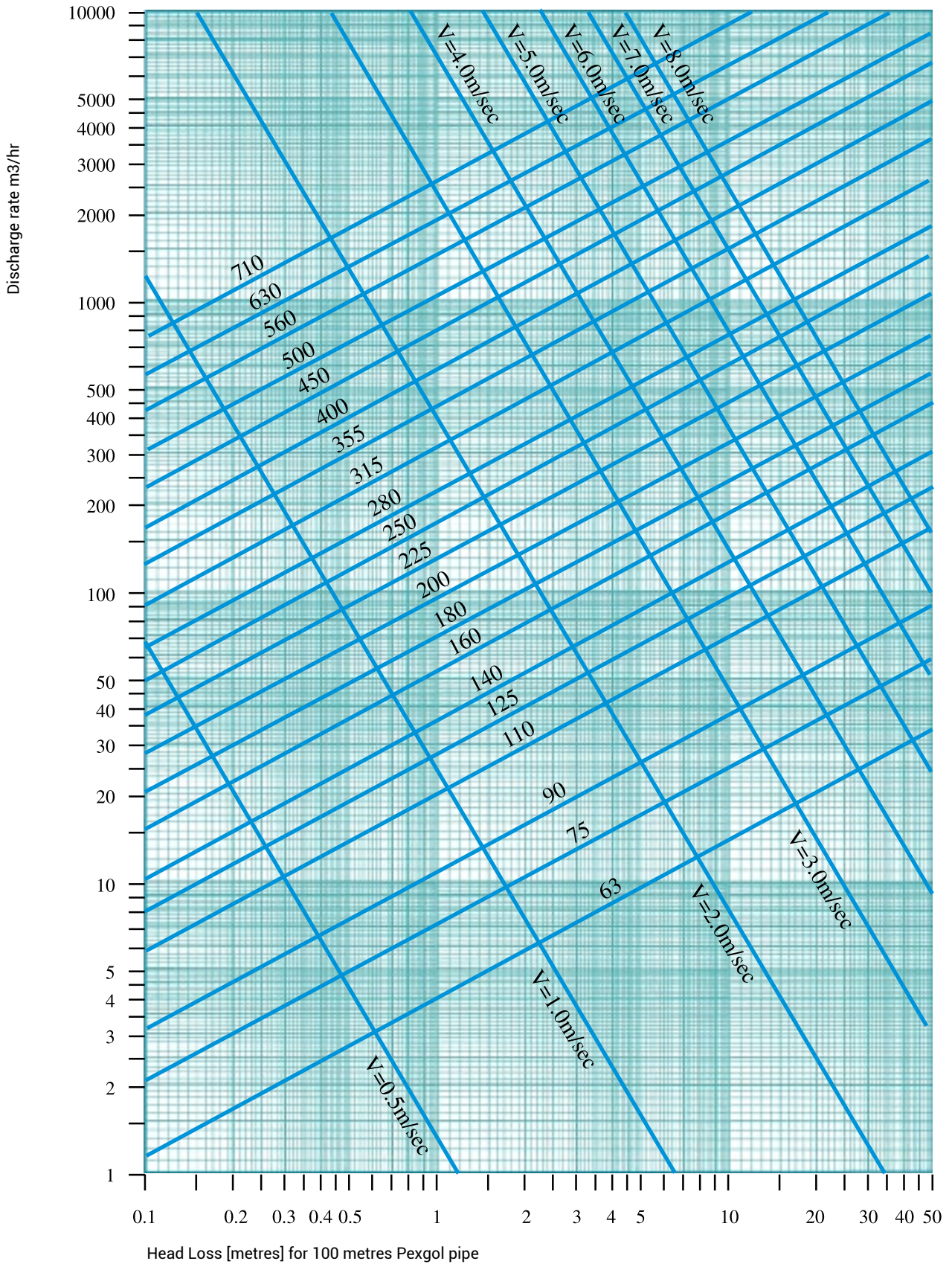
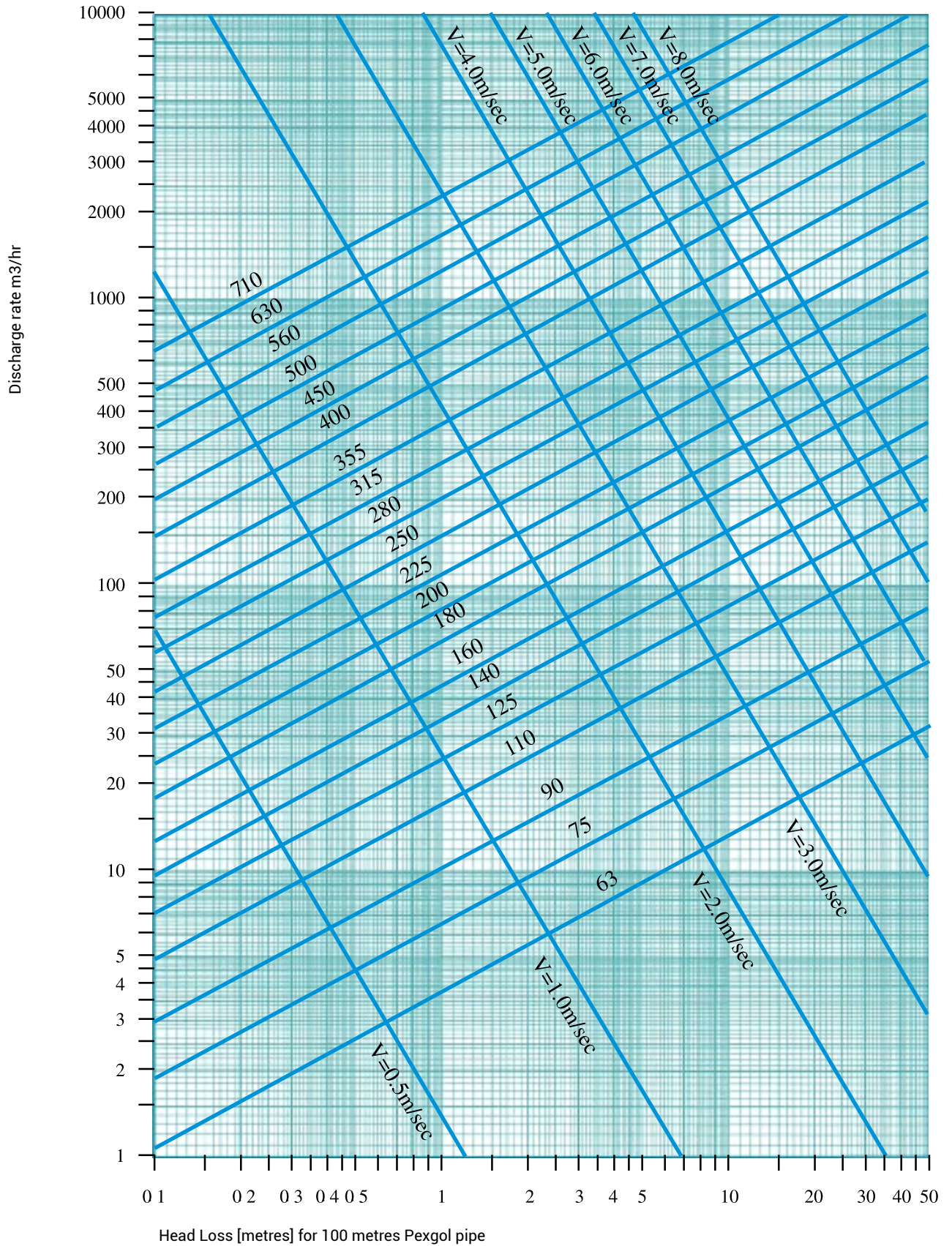

Chart 21.1 Class 24 (SDR 7.4)



2023

Technical information

Chart 22.1 Class 30 (SDR 6)

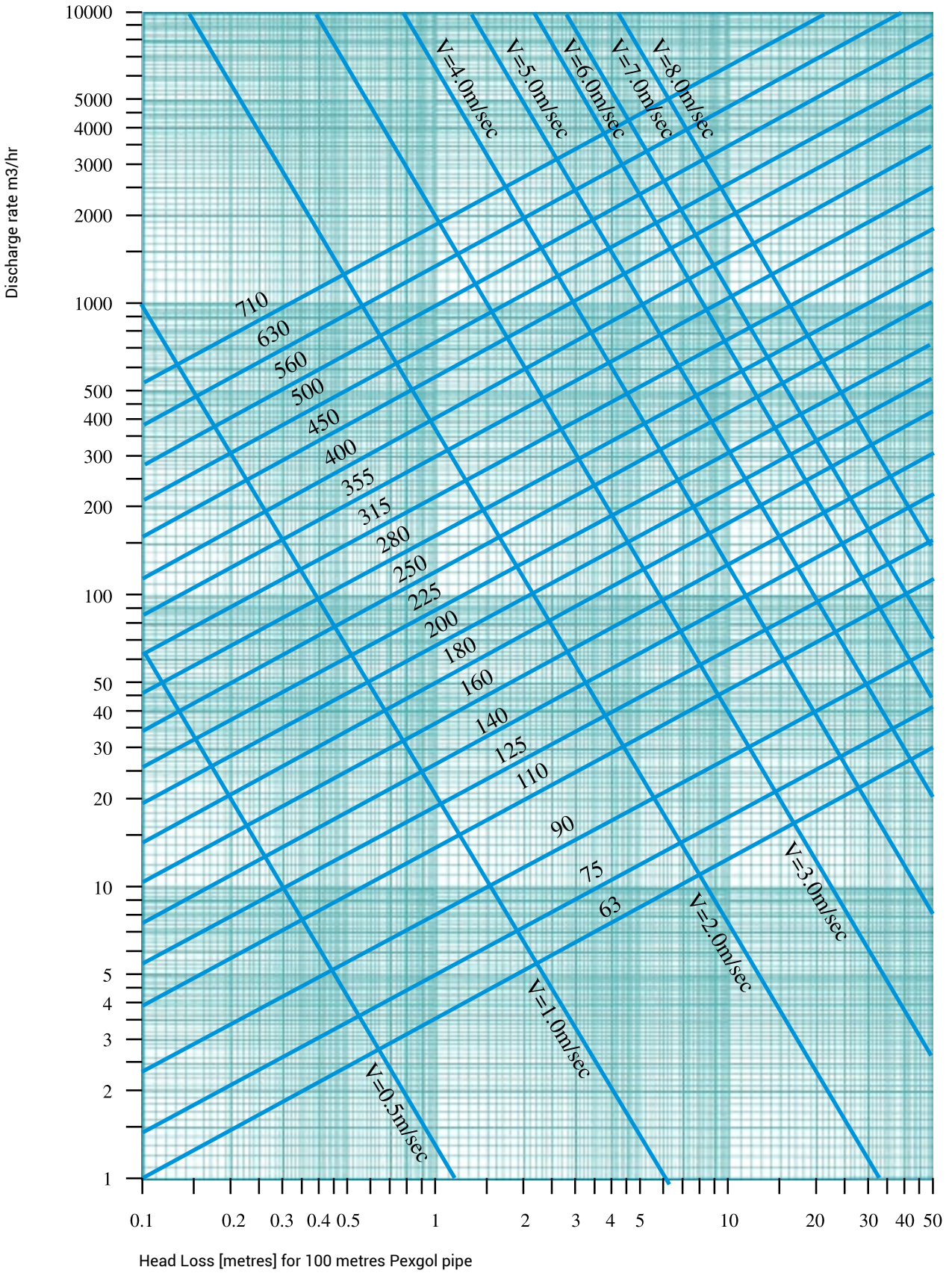
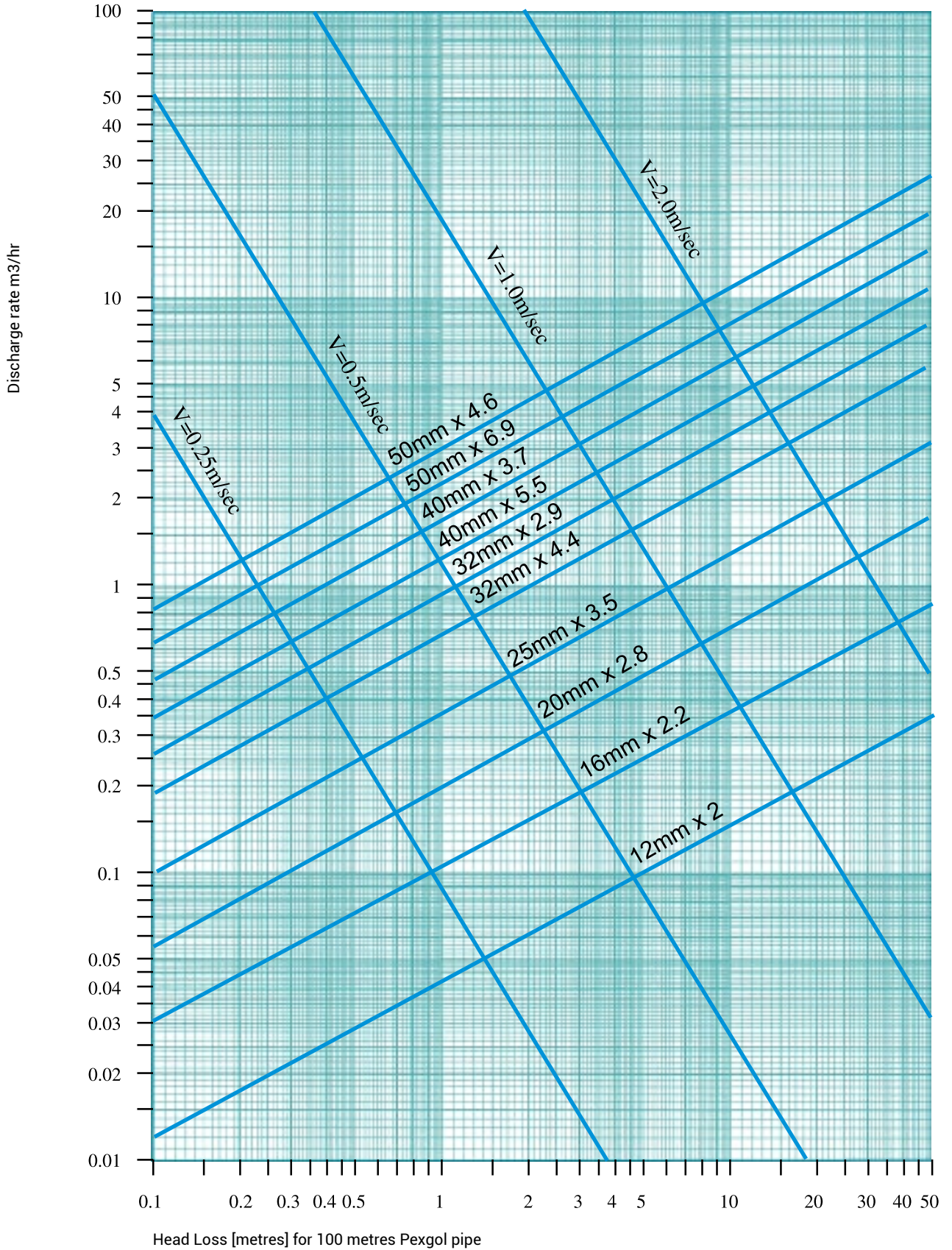

Chart 23.1 Class 24 (SDR 7.4) & Class 15 (SDR 11)



2023

Technical information

Coefficients of Friction

Absolute Surface Roughness

0.0005 mm – 0.0007 mm

The Values of the Hazen-Williams Coefficient

The values of the head losses in the charts were calculated using the Hazen-Williams formula with Hazen-Williams coefficient $C = 155$

Manning Coefficient

$n = 0.005 - 0.007$

Reduction Factors for Higher Temperatures

The values of the head losses J in the charts are correct for 20°C. At higher temperatures the head losses are lower. For different temperatures, multiply the value of J by the following reduction factors:

10 °C – 1.03
20 °C – 1.00
30 °C – 0.98
40 °C – 0.93
50 °C – 0.91
60 °C – 0.88
70 °C – 0.85
80 °C – 0.83
90 °C – 0.81

Calculating Pexgol Pipes for Boreholes

Pexgol pipes can be used as riser pipes for boreholes. For energy-saving reasons, we recommend choosing a Pexgol pipe with head losses that do not exceed $J = 5\%$, and preferably lower.

However, please note that designing these pipes is complicated, due to the complex three-dimensional stress regime in these applications. Golan's Technical Department will calculate the pipe design for you after receiving the completed borehole questionnaire (page 98).

Pexgol Properties

Test / Resina	Standard	Required	Nominal	Frequency
MFR	ASTM D1238 ISO 1133	1.7 – 2.3	1.9	Every Batch
Density	ASTM D1505 ISO 1183	926 Kg/m ³	955 Kg/m ³	Every Batch
Water Content	ASTM D6869 ISO 15512	<0.1%	<0.1%	Every Batch
Every Batch				
Melt Flow Rate (MFR)	ASTM D1238	1.0 – 3.0	1.61	Every Batch
Carbon Black Content (CBC)	ASTM D4218	2.0 – 2.6	2.4	Every Batch
Pipe				
Density	ISO 1183	938 kg/m ³	938 kg/m ³	
Cross Linking Degree	ISO 10147	70%	80%	At least twice a batch
Elongation at break (at 20°C)	ISO 6259-1, ISO 6259-3	350%	>400%	Every Batch
Tensile strength (at 20°C and at 100°C)	ISO 6259-1 ISO 6259-3	19 N/mm ² 19 N/mm ²	>19 N/mm ²	At least twice yearly
UV Resistance	ISO 14531-1, Annex C Resistance to Weathering	a) Thermal stability b) 95°C Hydrostatic strength c) Elongation at break	Comply	Type test
Longitudinal reversion	ISO 2505	<3%	<2.5%	Every Batch
Stabilisers Migration	NCh2086	At least 50% of a virgin sample	>50%	Annually
Oxidative Induction Time (OIT)	EN 728 ISO TR 10837	>20 min at 200°C	>40 min at 200°C	Every Batch
Oven aging 160°C	ATEC	After 100 hours, at least 50% elongation compared to virgin material	After 100 hours, 90% elongation compared to virgin material	Twice weekly
Thermal stability at 110°C	EN15632	15,000 h	>25,000	Type Test
Pent Test	ASTM F876	100 hs	>100 hs	Once per year
Squeeze-off	ISO 14531	1.000 hs (Pre cooling at -50°C)	>1.000 hs	Type Test
RCP	ISO 14531	lc/dn ≤ 4.7; a -50°C	lc/dn = 0.2 a -50°C	Type Test
Impact strength at 20 °C	DIN 53453	No failure	No failure	Type Test
Impact strength, at -140 °C Surface Energy Moisture absorption at 20 °C		No failure 34x10-3 N/m 0.01 mg/4d	No failure 34 x 10 - 3 N/m < 0.01 mg/4d	Type Test
Oxygen permeability (at 80°C) for pipe with oxygen barrier acc. To EN 15632	ISO 17455	≤3.60 mg O ₂ /(m ² /d)	≤2.0 mg O ₂ /(m ² /d)	Type Test

2023

Technical Information

Table 25.1: Thermal Properties

	Value	Unit	Tested for Standard
Service Temperature Range	-50 up to + 115	°C	
Coefficient of Linear Expansion at 20°C	1,4 x 10-4	m/m*°C	DIN53752
Coefficient of Linear Expansion at 100°C	2,05 x 10-4	m/m*°C	
Softening Temperature	+ 133	°C	
Specific Heat	2,3	kJ/Kg*°C	DIN53765
Coefficient of Thermal Conductivity	0,35	Watt/m*°C	DIN 4725

Table 25.2: Electronic Properties

	Value	Unit	Tested for Standard
Specific internal resistance at 20°C	10 ¹⁵	Ω.m	
Dielectric constant at 20°C	2,3	-	
Dielectric loss factor at 20°C/50Hz	1 x 10-3	-	DIN53483
Rupture voltage at 20°C	100	kV/mm	

International Approvals Standard and Guidelines

To view complete certification list, please visit our website www.pexgol.com



Chemical Resistance

The Pexgol Chemical Resistance List is based on information included in the professional literature. The list is only intended as a guide. Changes in the composition of the medium or special working conditions could lead to deviations. Consult the Golan Plastic Product experts in each specific case.

Chemical Resistance Test for Pexgol Pipes

The following procedure is an initial test for the chemical resistance of Pexgol pipes. Each combination of service conditions (service temperature, chemical concentration) constitutes a different case. However, for the same pipeline, the worst case is usually the highest temperature and the highest concentration.

The tested items are 20 "dumbbells" (also called "dogbones" or "coupons") made from Pexgol pipes.

Immersion Test

- The dumbbells are immersed in the same material transported through the pipeline (same chemical composition and same temperature) for a period of 4 weeks.
- After 2 weeks, 10 dumbbells are removed and stored.
- After an additional 2 weeks, the other 10 dumbbells are removed.
- The two groups of dumbbells are packed separately and the packages are marked appropriately to identify the removal and storage conditions.
- The packages are sent to Golan for tensile testing.

Classification

- A.** Resistant: can be used within the working pressures (safety factor of 1.25).
- B.** Conditionally resistant: restrictions of 70% to 90% must be made regarding the working pressures.
- C.** Conditionally resistant: can be used within pressures up to 60% of the working pressures.
- D.** Conditionally resistant: can be used within pressures up to 20% of the working pressures.
- U.** Unknown: not recommended.

In case of dangerous liquids (strong acids and bases) the safety factor should be increased to 1.5 or 2.0.

In case of doubt please consult us.



Compound	Chemical Resistance			
	40°C	60°C	80°C	100°C
Accumulator Acid	A	A	A	
Acetaldehyde 40%	A	A		B
Acetaldehyde 100%	U			
Acetamide	A	A	A	
Acetic Acid 05%	A	A		
Acetic Acid 10%	A	A		
Acetic Acid 20%	A	A		
Acetic Acid 50%	A	A		
Acetic Acid 60%	A	A		
Acetic Acid 80%	A	A		
Acetic Acid Ethyl Ester	A	A		
Acetic Anhydride	A	D		
Acetoacetic Acid	A			
Acetone	C			
Acetophenone			B	
Acetyl Bromide	U			
Acetyl Chloride			B	
Acetylene	A	A	A	
Acetylene Dichloride		see Dichloroethylene		
Acid mixture H2SO4-HNO3-H2O	U			
Acid mixture H2SO4-H3PO4-H2O		B		
Acrylic emulsions	A			
Acroline dispersion	A			
Acroline solution	B			
Acronal	C			
AcryloNitrile	A	A	A	
Acrylic Acid	A	A		
Adipic Acid	A	A	A	
Air	A	A	A	
Aktivin	A	A		
Alcohol		see Ethylalcohol		
Aliphatic Esters	A	A	A	
Allyl Acetate	A	C		
Allyl Alcohol 7%	A	A	A	
Allyl Alcohol 95%	A			
Allyl Aldehyde		see Acroline		
Allyl Chloride	C	U		
Alum	A	A	A	B
Aluminium Acetate	A	A	A	
Aluminium Chloride	A	A	A	

Compound	Chemical Resistance			
	40°C	60°C	80°C	100°C
Aluminium Fluoride	A	A	A	
Aluminium Hydroxide	A	A	A	
Aluminium Metaphosphate	A	A		
Aluminium Nitrate sol.	A	A	A	
Aluminium Phosphate	A	A	A	
Aluminium Potassium Phosphate	A	A	A	
Aluminium Potassium Sulphate	A	A	A	A
Aluminium Sodium Sulphate sol.	A	A	A	
Aluminium Sulphate	A	A	A	
Amino Acids	A	A		B
Aminoacetic Acid	B	B		
Ammonia Aqueous	A	A	A	
Ammonia, dry gas	A	A	A	
Ammoniacal Liquor	A	A		
Ammonium Acetate	A	A	A	
Ammonium Aluminium Sulphate	A	A		
Ammonium Bromide	B	B		
Ammonium Carbonate	A	A	A	
Ammonium Chloride	A	A	A	
Ammonium Fluoride 20%	A	A	A	
Ammonium Hydrogen Carbonate	A	A	A	
Ammonium Hydrogen Sulphide	A	A	A	
Ammonium Hydroxide	A	A	A	
Ammonium Metaphosphate	A	A	A	
Ammonium Molybdate	A		B	
Ammonium Nitrate	A	A	A	
Ammonium Persulphate	A	A	A	
Ammonium Phosphate	A	A	A	
Ammonium Sulfide	A	A	A	
Ammonium Sulphate	A	A	A	
Ammonium Sulphocyanide	A			
Ammonium Thiocyanate	A	A	A	
Amyl Acetate	A	A		
Amyl Alcohol	A	A	A	
Amyl Chloride	U			
Amyl Methyl Carbinol	B			
Amyl Naphthaline	B			
Amyl Phthalate	A	B		
Aniline Hydrochloride	D			
Aniline Sulphate	U			
Aniline, coloured		see Aniline		
Aniline, pure	A	A		

Compound	Chemical Resistance			
	40°C	60°C	80°C	100°C
Aniline, water soluble	B			
Animal Fats	A	A	A	
Animal Oils	B	B	B	
Anis Oil	B			
Aniseed Oil	C	U		
Anisole	see Cyclohexanone			
Antifreeze solution	A	A	A	
Antimony Pentachloride	A	A	A	
Antimony Trichloride	A	A	A	
Antrhoquinone Sulphonic Acid	A	A		
Aqua Regia	U			
Aromatic Acids	A	A	A	
Aromatic Hydrocarbons	U			
Arsenic	B	B		
Arsenic Acid 80%	A	A	A	
Arsenic Acid Anhydride	A	A		
Arsenic Salts	A			
Arsenic Trichloride	U			
Ascorbic Acid	A			
Asphalt	A	C		
ASTM Oil no. 1	A	A	A	
ASTM Oil no. 2	A	A	A	
ASTM Oil no. 3	A	A	A	
Atropine Sulphate	A			
Barium Carbonate	A	A	A	
Barium Chloride	A	A	A	
Barium Hydrosulphide, Bone Oil			B	
Barium Hydroxide	A	A	A	
Barium Salts	A			
Barium Sulphate	A	A	A	
Barium Sulphide	A	A	A	
Battery Acid	A	B		
Beater Glues	A			
Beer Colours	A	A	A	
Beer, trading quality	A			
Beet Juice	A	A		
Benzaldehyde 0.1%			C	
Benzaldehyde 100%	A	C		
Benzaldehyde Oxime 2%	A			
Benzaldoxime	see Benzaldehyde Oxime			
Benzene (Benzole)	D	U		

Compound	Chemical Resistance			
	40°C	60°C	80°C	100°C
Benzene Carbonic Acid	see Benzoic Acid			
Benzene Dicarboxylic Acid	see Phthalic Acid			
Benzene Sulphonic Acid	A		B	
Benzoic Acid	A	A	B	
Benzole Carbon Acid	see Benzoic Acid			
Benzole Dicarboxylic Acid	see Phthalic Acid			
Benzole Sulphonic Acid	U			
Benzyl Acetate	B			
Benzyl Alcohol	A	A	B	
Benzyl Benzoate		B		
Benzyl Chloride	A			
Bichromate Sulfuric Acid	B	U		
Bismuth Carbonate	A	A	A	
Bisulfite	see Sodium Bisulfite			
Bitumen	A	C		
Black Liquor	B	B		
Bleach	D U			
Bleach Lye 10%	B	B		
Bloodstream Salt, red	see Potassium Ferricyanide			
Bloodstream Salt, yellow	see Potassium Ferricyanide			
Bone Oil	A	A		
Bonewax	A		U	
Borax	see Sodium Tetraborate			
Boric Acid	A	A	A	
Boric Acid Methyl Ester	B	U		
Boric Copper Sulphate	A			
Boric Trifluoride	A			
Boron Trifluoride	A	D		
Brake Fluids	A	A	A	
Brandy	A			
Brines, saturated	A	A	A	A
Brom Oil	A		B	
Bromate Solution	A A			
Bromoethane	U			
Bromic Acid	A	A	A	
Bromine Vapours, low conc.	B			
Bromine Water	U			
Bromine, Liquid	U			
Bromochloromethane	U			
Butadiene 50%	A	A	A	
Butadiene 100%	B			

Compound	Chemical Resistance			
	40°C	60°C	80°C	100°C
Butane (gas)	U			
Butanediol up to 10%	A	A	A	
Butanediol up to 100%	B			
Butanetriol	A	A		
Butanol 100%	A	A	A	
Butanone	A	U		
Butene	U			
Butoxyl	A	C		
Butter	A		B	
Butter Acid	C			
Butter Acid in water, conc.	C			
Butter Acid in water, sol. 20%	C			
Butyl Acetate	A	B	C	
Butyl Acrylate	A	B		
Butyl Alcohol	see Butanol			
Butyl Aldehyde	A		B	
Butyl Benzyl Phtalate	A	A		
Butyl Carbinol			B	
Butyl Cellulose solution	U			
Butyl Phenol	U			
Butyl Stearate	A	A	A	
Butylene	see Butene			
Butylene Glycol	see Butanediol			
Butyric Acid	C	D		
Cadmium Salts	A			
Caffeine Citrate	B	B		
Calcium Acetate	A	A	A	
Calcium Bisulphide	A	B		
Calcium Bisulphite	A	A	A	
Calcium Bromide 50%	A	A		
Calcium Bromide 80%	A			
Calcium Carbide	A	A		
Calcium Carbonate (Soda)	A	A	A	
Calcium Chlorate	A	A	A	
Calcium Chloride	A	A	A	B
Calcium Hydrosulphite containing SO2	B	B		
Calcium Hydroxide	A	A	A	
Calcium Hypochlorite	A	A	A	
Calcium Nitrate	A	A	A	
Calcium Oxide	A			

Compound	Chemical Resistance			
	40°C	60°C	80°C	100°C
Calcium Phosphate	A			
Calcium Sulphate	A	A	A	
Calcium Sulphide			B	
Calcium Water	A			
Camphor	C			
Cane Sugar	A			
Cane Sugar Juice	A	A	A	
Carbamide 33%	A	A	A	
Carbazole	A	A		
Carbolic Acid	A	B		
Carbolic Acid (Phenol)	A	A		
Carbolineum	A	C		
Carbon Bisulfide	U			
Carbon Dioxide	A	A	A	
Carbon Dioxide damp	A	A	A	
Carbon Dioxide dry	A	A	A	A
Carbon Disulphide		D	U	
Carbon Monoxide - lamp gas	A	A	A	
Carbon Tetrachloride		D	U	
Carbonic Acid H2CO3	A	A		
Carnbevox	A			
Carrot Juice	A	A		
Castor Oil	A	B		
Caustic Potash	A	A		
Caustic Soda	see Sodium Hydroxide			
Cedar Leaf Oil	D			
Cedar Wood Oil	D			
Cellulose Dissolver	see Ethylene Glycol Monoethyl Ether			
Cetyl Alcohol	A	A	B	
Chalk	A	A	A	
Cheese Enzyme	A	A	A	
Chloral Hydrate	A	A	A	
Chloramine	A	A	A	
Chloramine T	see Para Toluene Sulfonyl Chloride			
Chloride Acid	see Hydrochloric Acid			
Chlorine water 10 PPM	A	A		
Chlorine water saturated	A		B	
Chlorine, damp gas	C	U		
Chlorine, dry gas	B		U	
Chlorine, liquid	U			

Compound	Chemical Resistance			
	40°C	60°C	80°C	100°C
Chloroacetic Acid Ethyl Ester	A	A		
Chloroacetic Acid Methyl Ester	A	A		
Chloro Carbonic Acid	A	C		
Chloroacetic Acid 85%	B	B		
Chloroacetic Acid 98%	B			
Chloroacetic Acid 100%		B		U
Chlorobenzene	D	U		
Chlorocalcium (in H2O)	A	A	A	
Chloroethane	see Ethyl Chloride			
Chloroethanol	A	A	A	
Chloroethyl Alcohol	see Chloroethanol			
Chloroethyl Phosphate	A	A		
Chloroform	D	U		
Chloromethane	see Methyl Chloride			
Chloropicrin	U			
Chloropropane	see Glycerine Chlorhydrin			
Chlorosulfonic Acid	U			
Chrome Alum	A	A	A	
Chrome Anode Mud	A	A		
Chrome Mercury	B			
Chromic Acid 50%	A	A	A	
Chromic Acid 80%	A		B	
Chromic Acid Anhydride	see Chromium Trioxide			
Chromium Oxide	see Chromium Trioxide			
Chromium Salts	A			
Chromium Trioxide 20%	A	A	A	
Chromium Trioxide 50%	A		B	
Chromium Trioxide 80%				
Chromosulfuric Acid	A	U		
Cider	A	B		
Cinnamon	B	C		
Cinnamon Oil	D			
Cis - Oxime	see Benzaldehyde Oxime			
Citric Acid	A			
Citronella	B	D		
Citrus Juices	A	A		
Cloves	C	C		
Coal Tar	D	U		
Cobalt Chloride	A	A	A	
Coca Cola	A	A		
Coca Cola Syrup	A	B		

Compound	Chemical Resistance			
	40°C	60°C	80°C	100°C
Coconut Oil Alcohols	B	C		
Cocoa Fat	A	A	A	
Cocoa Fat Alcohol	A	A	A	
Coconut Oil	A	B		
Cod Liver Oil	B	C		
Coffee	A			
Cognac	A			
Kola nut, concentrated	A	A	A	
Cooking Salt	see Sodium Chloride			
Copper Acetate			B	
Copper Chloride (Cupric)	A	A	A	
Copper Chloride (Cuprous)	A	A	A	
Copper Cyanide	A	A	A	
Copper Fluoride	A	A	A	
Copper Nitrate	A	A	A	
Copper Salts	A	A		
Copper Sulphate	A	A	A	
Corn Oil	A	A	A	
Corn Syrup	A	A		
Cottonseed oil	A	B	C	
Coumarone Resins	A	A		
Cranberry Sauce	B	B		
Creosote	A	B		
Cresol 100%	A	C		
Cresol, diluted	A	C		
Crop Protection Agent	A	A		
Croton Aldehyde	A	C		
Crude Oil	A	B	C	D
Cupric Salts Cuprous Chloride	A			
Saturated	B	B		
Cuprous Oxide	B	B		
Cyanides	A	A	A	
Cyclanone	A	A		
Cyclohexane	C	D		
Cyclohexanol	A			
Cyclohexanone	D	U		
Cyclohexyl Alcohol	A	B		
DDT	A	A		
Decahydro Naphthalene	B	C		
Decalin	A	C		
Defoamer	A	C		

Compound	Chemical Resistance			
	40°C	60°C	80°C	100°C
Denatured Spirit	see Methyl Alcohol			
Deodorants	A	A		
Detergents	A	B		
Dextrine	A	A	A	
Dextrose	A	A	A	A
Diacetone	A	A	A	
Diacetone Alcohol	A			
Diammonium Salts	A	A	A	
Diazo Salts	A	A		
Dibenzyl Ether			B	
Dibromoethane	D	U		
Dibutyl Ether	B	D		
Dibutyl Phthalate	B	C		
Dibutyl Sebacate	A	B	B	
Dichloroacetic Acid	A	A	A	
Dichloroacetic Acid Methyl Ester	A	A	A	
Dichlorobenzene	C	U		
Dichloroethane	see Ethyl Chloride			
Dichloroethylene	U			
Dichloromethane	see Methyl Chloride			
Dicyclohexamine	B			
Diesel Fuel	A	U		
Diesel Oil	A	U		
Diethylene Glycol Monobutylene	A			
Diethyl Benzene	B			
Diethyl Ether	see Ethyl Ether			
Diethyl Ketone	B	C		
Diethyl Phthalate	A			
Diethylamine	B			
Diethylene Dioxide	see Dioxane			
Diethylene Glycol	A	A		
Diglycolic Acid	A	A	A	
Dihexyl Phthalate	A	A	A	
Diisobutylene			B	
Diisopropyl Ether	B	U		
Diisopropyl Ketone	A	A	A	
Dimethyl Amine	C	U		
Dimethyl Aniline			B	
Dimethyl Benzole	see Xylol			
Dimethyl Formamide	A	B		
Dimethyl Ketone	see Acetone			

Compound	Chemical Resistance			
	40°C	60°C	80°C	100°C
Dimethyl Phthalate	A	A	A	
Dimethyl Sulphoxide	A	A		
Diocetyl Phthalate	B	C		
Diocetyl Sebacate			B	
Dioxalane			B	
Dioxane	A	B	C	
Dioxyethyl Ether	see Diethylene Glycol			
Diphenyl			B	
Diphenyl Amine	A	C		
Diphenyl Oxide	B	C		
Dishwasher Detergents	A	A	B	
Disodium Phosphate	A	A		
Disodium Sulphate	A	A		
Dispersions	A			
Dodecylbenzene Sulfonic Acid	A	C		
Dop (Diethylhexyl Phthalate)	A	C		
Edible Oil	A			
Electrolyte 10%	A	A	A	
Elementine normal conc.	A	A	A	A
Emulsions, Photographic	A	A	A	
Engine Oils	A	C		
Ephetin	A	A		
Epichlorohydrin	A	A	B	
Epoxy Ethane	see Ethylene Oxide			
Epsom Salts	A	A		
Essential Oils	C	U		
Esteric Oils	B	B	B	
Ethanal	see Acetaldehyde			
Ethandiol	see Ethylene Glycol			
Ethane	A	A		
Ethane Diamine	see Ethylene Diamine			
Ethanol	see Ethyl Alcohol			
Ethanolamine	A	A	B	
Ethers	C	D	U	
Ethoxyethane	see Ethyl Ether			
Ethyl Acetate	A	B	C	
Ethyl Alcohol	A	A	A	B
Denatured with 2% Toluol plus Acetic Acid, quality use	A			
Ethyl Benzene	D	U		
Ethyl Benzoate	B			
Ethyl Carbitol			B	

Compound	Chemical Resistance			
	40°C	60°C	80°C	100°C
Ethyl Cellulose			B	
Ethyl Chloride	C	U		
Ethyl Dibromide	C	U		
Ethyl Ether	C	D	U	
Ethyl Formate			B	
Ethyl Glycol			B	
Ethyl Methyl Ketone		see Butanone		
Ethyl Oxalate	A	A	A	
Ethyl Pentachloro Benzene	U			
Ethyl Salicylate	B			
Ethyl Silicate	A	A	A	
Ethyl Valeriate	A			
Ethylamine	A	A	A	
Ethylene	A	B		
Ethylene Chlorhydrin	U			
Ethylene Chloride	U			
Ethylene Diamine	A	A		
Ethylene Diamine Tetraacetic Acid	A	A		
Ethylene Dichloride	D	U		
Ethylene Glycol 100% trading quality	A	A	A	B
Ethylene Glycol\Monoethyl Ether	A			
Ethylene Oxide, gaseous	A	A		
Ethylene Oxide, liquid	U			
Ethylene Trichloride	D			
Ethylhexyl Alcohol	A	B		
Eugenol	B			
Euron B	B	B		
Euron G	A	A		
Fatty Acid	A	B	C	
Fatty Acid Amides	A	C		
Fatty Alcohols	A	C		
Fatty Oils	A	C		
Ferric Chloride	see Iron Chloride			
Ferric Nitrate	see Iron Nitrate			
Ferrous Ammonium Citrate	A	B		
Ferrous Chloride	A	B		
Ferrous Sulphate Fe SO4	A	A		
Fertiliser Salts	A	A	A	B
Fir Wool Oil	A	C		
Fish Oil	A	A	A	

Compound	Chemical Resistance			
	40°C	60°C	80°C	100°C
Fish Solubles		B		
Fluoboric Acid	A	B		
Fluorbenzene	U			
Fluorides	A	A	A	
Fluorine, liquid	C			
Fluorine (solution)	U			
Fluosilicic Acid 25%	A	C		
Formaldehyde 40%	A	A		
Formaldehyde, diluted	A	A	A	
Formamide	A	A	A	
Formic Acid	A	A	B	
Freon 12	C	U		
Freon 13	A	A	A	
Freon 21	U			
Freon 22	A	A	A	
Freon 113	A			
Freon 114	A	A	A	
Frigen	C	U		
Fructose	A	A		
Fruit Juice	A	A	A	
Fruit Mass (fruit pulp)	A	A	A	
Fruit Sugar	A			
Fuel Oils	A	D		
Fuming Sulphuric Acid	see Oleum			
Furan	D			
Furfural	A	C	U	
Furfural Alcohol	A	B		
Gallic Acid	A	A		
Gas Liquor	A	A		
Gas, Natural	see Natural Gas			
Gases, containing Carbon Dioxide, Carbon Acid	A	A	A	A
Gases containing Chlorine	A	A	A	B
Gases, containing Fluorine traces	A	A	A	
Gases, containing Nitrous Oxide traces	A	A	A	
Gases, containing Oleum, low conc.	U			
Gases, containing Sulphur Dioxide 50%	A	A		
Gases, containing Sulphur Dioxide, low conc.	A	A	A	B
Gases, containing Sulphuric Acid	A	A	A	

Compound	Chemical Resistance			
	40°C	60°C	80°C	100°C
Gasoline-Benzene mixture 80/20	B		C	
Gasoline, Leaded	A			
Gasoline, pure, 100 Octane	B	C		
Gasoline, Sour	A			
Gasoline, Unleaded	A			
Gelatine	A	A	A	
Genantin	A	A		
Gin	A	A		
Glaubers Salt	A	A		
Glucose	see Dextrose			
Glycerine Chlorhydrin	A	A	A	
Glycerine, Glycerol	A	A	A	
Glycerol Chlorohydrin	A	A		
Glycine	see Glycol			
Glycois	A	A		
Glycol	A	A		
Glycol Dichloride	see Ethylene Chloride			
Glycol Ester	A	A	A	
Glycolic Acid 37%	A	B		
Glycolic Acid Butyl Ester	A	A		
Glystantin	A	A		
Grape Juice	A	A		
Grape Sugar	A	A		
Grapefruit Juice	A	A		
Grease	A			
Grisiron 8302	B	B		
Grisiron 8702	A	A		
Hair Oil/Tonic Oil	A	A		
Halothane	C	D		
Hand Lotions	A	A		
Heating Oil, Barrel Oil	A			
Heavy Emulsion	see Barium Carbonate			
Heavy Oil	B			
Heptane	B	D		
Hexachlorobenzene	A	B		
Hexadecylalcohol	A	A		
Hexane	C	D		
Hexanetriol	A	A		
Hexyl Alcohol	D			
Honey	A			
Household Cleaners	A	B		

Compound	Chemical Resistance			
	40°C	60°C	80°C	100°C
Hydrobromic Acid 20%	A	A		
Hydrobromic Acid 50%	A	A		
Hydrochloric Acid 10%	A	A	A	
Hydrochloric Acid 20%	A	A	A	
Hydrochloric Acid < 30%	A	A	A	
Hydrochloric Acid ≥ 30%	A	A	B	
Hydrochloric dry gas	A			
Hydrocyanic Acid	see Hydrogen Cyanide			
Hydrocyanic Acid 10%	A	C		
Hydrofluoric Acid 20%	A	A		
Hydrofluoric Acid 50%	A	A		
Hydrofluoric Acid 75%, HF	A	A		
Hydrofluosilicic Acid	A	A		
Hydrogen	A	A	A	
Hydrogen Bromide	A	A	A	
Hydrogen Chloride gas dry and moist	A	A	A	
Hydrogen Cyanide	A	A	A	
Hydrogen Fluoride 40%	A	A		
Hydrogen Fluoride 70%	A			
Hydrogen Peroxide 30%	A	A	A	
Hydrogen Peroxide 50%	B			
Hydrogen Peroxide 90%	C			
Hydrogen Peroxide 100%	A			
Hydrogen Phosphide	A			
Hydrogen Sulphide, H ₂ S	A	A	A	B
Hydrogen Sulphide (Aq. Sol.)	A	A	A	B
Hydrogen Sulphide, dry	A	A	A	
Hydroquinone	A	A		
Hydrosulphite	A	A		
Hydroxylamine Sulphate	A	A		
Hypochlorous Acid	A	A		
Hydraulic Fluids	A	B		
Hyrazine Hydrate	A	A		
Igepal	A	A	A	
Ink	A	A	A	
Iodine	A			
Iodine, alcoholic sol.	B			
Iodine ink	A			
Iodine-Potassium Iodide, 3%	A	A		
Iodine Solution	U			

Compound	Chemical Resistance			
	40°C	60°C	80°C	100°C
Iodine, Tincture of	A	C		
Iron (II) Chloride	A	A	A	
Iron (II) Sulphate	A	A	A	
Iron (III) Chloride	A	A	A	A
Iron (III) Nitrate	A	A	A	
Iron (III) Sulphate	A	A	A	
Isobutyl Alcohol	A	A		
Isooctane	A	B		
Isopropanol	A	A		
Isopropyl Acetate	A	C		
Isopropyl Ether	D	U		
Jams	A	A		
Kerosene	B	C		
Kerosine	B	C		
Ketones	B	D		
Labarraques Solution	D	U		
Lacquer	U			
Lactic Acid 90%	A	A	A	
Lactose	A	A		
Lanolin	A	A	A	
Latex	A			
Lauryl Alcohol	B			
Lavender Oil			B	
Lead Acetate	A	A	A	B
Lead Arsenate	A			
Lead Nitrate	A	A	A	
Lead Sulphamate	A	A	A	
Lemon Juice	A	A		
Lemon Oil	B	U		
Lime	A	A		
Lime Chloride	A	A		
Lime Juice	B	B		
Lime Water	A	A		
Lind Oil	A	B	C	
Liquor, Trading Quality	C	U		
Lithium Bromide	A	A		
LPG	A	A		
Lubricating Oils	A	C		
Machine Oils	A	B		
Magnesium Carbonate	A	A	A	
Magnesium Chloride	A	A	A	

Compound	Chemical Resistance			
	40°C	60°C	80°C	100°C
Magnesium Fluosilicate	A	A		
Magnesium Hydroxide	A	A	A	
Magnesium Iodine	A	A		
Magnesium Nitrate	A	A	A	
Magnesium Salts	A	A		
Magnesium Sulphate	A	A	A	A
Maleic Acid	A	A	A	A
Malic Acid	A	A		
Manganese Sulphate	A	A	A	
Manure, liquid	A	A		
Margarine	B	C		
Marmalade	A	A	A	
Masa	A	A		
Mascara	A	A	A	
Mash	A	A		
Mayonnaise	A			
Molasses spices, industrial conc.	A	A	A	
Molasses, industrial conc.	A	A	A	A
Menthanol				see Menthol
Menthol	A	C		
Mercuric Chloride	A	B		
Mercuric Cyanide	B	B		
Mercurochrome	A	A		
Mercurous Nitrate	B	B		
Mercury	A	A	A	
Mercury Salts	A	A	A	
Mesityl Oxide				B
Metallic Mordants	A	A		
Methacrylate	A	A		
Methacrylic Acid	A	A		
Methane				B
Methane Amide				see Formamide
Methanol				see Methyl Alcohol
Methoxy Butanol	A	A	A	
Methoxybutyl Alcohol	A	B		
Methyl-2-Pentanone (4-)	A	A		
Methyl Acetate				B
Methyl Alcohol	A	A	A	
Methyl Amine, 32%	A			
Methyl Bromide				see Bromethane
Methyl Butyl Ketone	A	A	A	

Compound	Chemical Resistance			
	40°C	60°C	80°C	100°C
Methyl Cellulose Solvent	A			
Methyl Chloride	D	U		
Methyl Ethyl Ketone	B	D		
Methyl Formate			B	
Methyl Glycol	A	A	A	
Methyl Isobutyl Ketone	A	C		
Methyl Methacrylate	A	A	B	
Methyl n-Propyl Ketone	A	B		
Methyl Oleate	A	A	A	
Methyl Phenol		see Cresol		
Methyl Pyrrolidone	A	A		
Methyl Salicate	B			
Methyl Salicylate	A	B		
Methyl Sulphate	A	A		
Methyl Sulphuric Acid up to 50%	B	B		
Methylbenzene	D	U		
Methylcyclohexane	C	D		
Methylene Chloride	C	U		
Milk	A	A	A	
Mineral Oils	B	U		
Mineral Spirits	A	C		
Mineral Water	A	A	A	
Molasses	A	A		
Mold Release	A	A		
Monochloride Acetic Acid	A	A	A	
Monochloride Acetic Acid Ethylester	A	A	A	
Monochloride Acetic Acid Methylester	A	A	A	
Monochloro Benzene	D			
Monoethanolamine	A			
Monoethyl Ether	A	A	A	
Monomethyl Aniline	A	A	A	
Morpholine	A	A		
Monopropylene Glycol	A	A	A	
Motor Oil			C	
Mowilth	A	A		
Mustard	A	B		
Nafta	B	U		
Naphthalene, Naphthaline	A	C		
Natural Gas	A	A		
Nickel	A			
Nickel Chloride	A	B		

Compound	Chemical Resistance			
	40°C	60°C	80°C	100°C
Nickel Nitrate	A	B		
Nickel Salts	A	A		
Nickel Sulphate	A	B		
Nicotine	A	A		
Nicotine Acid	B	B		
Nitric Acid 30%	A	A		
Nitric Acid 30-50%	B	C		
Nitric Acid 40%	B			
Nitric Acid 70%	C			
Nitric Acid 98%			U	
Nitrobenzene (Oil of Mirbane)	C	U		
Nitrocellulose	A			
Nitroethane	A		U	
Nitrogen	A	A	A	
Nitroglycerin	B	D		
Nitromethane	A		U	
Nitrotoluene	A	B		
Nitrous gases, conc.	A		U	
Nonyl Alcohol	A	A		
Octane	A	B		
Octyl Alcohol	A		B	
Octyl Cresol	B	U		
Oil	C	C		
Oil Acid			C	
Oleic Acid	A	C		
Oleic Acid (Red Oil)	U			
Oleum	U			
Oleum vapour (SO3)	B			
Olive Oil	A	A	A	
Optical Brighteners	A	A		
Orange Extract	A	A		
Ortho-Boric Acid		see Boric Acid		
Oxalic Acid	A	B		
Oxyacetic Acid		see Glycolic Acid		
Oxybensole		see Phenol		
Oxydiethanole		see Diethylene Glycol		
Oxygen	A	A		
Oxypropionic Acid		see Lactic Acid		
Oxyrane		see Ethylene Oxide		
l-Oxytoluol		see Benzyl Alcohol		
m-Oxytoluol		see Cresol		

Compound	Chemical Resistance			
	40°C	60°C	80°C	100°C
Ozone	C		U	
Painting Turpentine	see Thinner			
Palm Kernal Oil	A	A		
Palm Oil	B	B		
Palmitic Acid	A	A	B	
Palmityl Alcohol	A	A		
Palmolive Oil	A			
Paraffin	A	B	C	
Paraffin Emulsion, trading qual.		B		
Paraffin Oil	A	A	A	
Paraformaldehyde	A	A		
Paratoluene Sulpho Chloramide Sodium 1%	A			
Peanut Butter	B	B		
Pentanol	see Amyl Alcohol			
Pentanol Acetate	see Amyl Acetate			
Pepper	B	B		
Peppermint Oil	B	D		
Perchloric Acid 10%	A	A		
Perchloric Acid 20%	A	A	A	
Perchloric Acid 50%	A	B	C	
Perchloric Acid 70%	A	D		
Perchloro Ethylene	U			
Perfumes	C	U		
Petroleum	A	B	C	
Petroleum Ether	A	D		
Petroleum Jelly	B	B		
Petroleum Spirits	C	D		
Phenol up to 90%	A	A		U
Phenolic Resins	A	A		
Phenols 100% (Carbolic Acid)	D			
Phenyl Alcohol	see Benzyl Alcohol			
Phenyl Ethane	see Ethyl Benzene			
Phenyl Ethyl Alcohol	A	A		
Phenyl Hydrazine	C	D		
Phenyl Hydrazine Hydrochloride	A	U		
Phenyl Methane	see Toluol			
Phenyl Methyl Ether	see Cyclohexanone			
Phenyl Sulfonate	A	A		
Phosgene, gas	U			
Phosphates	A	A	A	

Compound	Chemical Resistance			
	40°C	60°C	80°C	100°C
Phosphoric Acid 80%	A	A	A	A
Phosphoric Acid 90%	A	A	A	A
Phosphoric Acid 95%	A	A		
Phosphorus Oxychloride	A	B	B	
Phosphorus Pentoxide	A	A	A	
Phosphorus Trichloride	A	B		
Phosphorus Yellow	A			
Photographic Developer	A	A		
Photographic solution, Fixer	A	A	A	
Phthalic Acid 50%	A	A	A	
Phtalic Acid Ester	A	C		
Phtalic Anhydride	B	B		
Pickling Baths	B	C		
Picric Acid 1%	A		B	
Pine Oil	B	D		
Pineapple Juice	A	A		
Pinene			B	
Plasticizers of Polyester	A	B		
Plating Solutions, Brass	A	B		
Plating Solutions, Cadmium	A	B		
Plating Solutions, Copper	A	B		
Plating Solutions, Gold	A	B		
Plating Solutions, Indium	A	B		
Plating Solutions, Iron	A	B		
Plating Solutions, Lead	A	B		
Plating Solutions, Nickel	A	B		
Plating Solutions, Rhodium	A	B		
Plating Solutions, Silver	A	B		
Plating Solutions, Tin	A	B		
Plating Solutions, Zinc	A	B		
Polyesters (Resins)	C	U		
Polyglycols	A	A		
Polysolvan O	A	A		
Potash Alum	A	A		
Potassium Acetate			B	
Potassium Bicarbonate	A	B		
Potassium Bichromate 40%	see Potassium Dichromate			
Potassium Bisulfate	A	A		
Potassium Borate 1%	A	A	A	
Potassium Bromate	A	A	A	
Potassium Bromide	A	A	A	

Compound	Chemical Resistance			
	40°C	60°C	80°C	100°C
Potassium Carbonate	A	A	A	
Potassium Chlorate	A	A	A	
Potassium Chloride	A	A	A	A
Potassium Chromate	A	A	A	
Potassium Chromium Sulphate	A	A	A	B
Potassium Cupro Cyanide	A	A	A	
Potassium Cyanide	A	A	A	
Potassium Dichromate 40%	A	A	A	
Potassium Ferricyanide	A	A	A	B
Potassium Ferrocyanide	A	B		
Potassium Fluoride	A	A	A	
Potassium Hydrogen Carbonate	A	A	A	
Potassium Hydrogen Sulphate	A	A	A	
Potassium Hydrogen Sulphite solution	A	A	A	
Potassium Hydroxide 50%	A	A	A	
Potassium Hydroxide 60%	A	A	B	
Potassium Hypochlorite, solution	A		B	
Potassium Iodide, cold saturated	A	A	A	
Potassium Nitrate	A	A	A	
Potassium Orthophosphate	A	A	A	
Potassium Perborate	A	A	A	
Potassium Perchlorate 1%	A	A	A	A
Potassium Perchlorate 10%	A			
Potassium Permanganate 18%	A	A	A	
Potassium Persulfate	A			
Potassium Phosphate	A	A	A	
Potassium Salts	A			
Potassium Sulphate	A	A	A	
Potassium Sulphate, cold saturated	A	A	A	
Potassium Sulphide	A	A	A	
Potassium Sulphite	A	A		
Potassium Supersulphate	A	A	A	
Potassium Tetracyano Cuprate	A	A		
Potassium Thiosulphate	A	A		
Propargyl Alcohol	A			
Propane Acid	see Propionic Acid			
Propanediol	see Propylene Glycol			
Propanetriol	see Glycerine			
Propane, gas	A	B		

Compound	Chemical Resistance			
	40°C	60°C	80°C	100°C
Propane, liquid	B			
Propanol	A	A	A	
Propanone	see Acetone			
Propargyl Alcohol	A	B		
Propene	A	A	A	
Propionic Acid	A	A	A	
Propyl Acetate			B	
Propyl Alcohol	see Propanol			
Propylene Dichloride	U			
Propylene Glycol	A	A	A	
Propylene Oxide	A	A		
Prune Juice	A			
Pseudocumol/ Pseudocumene	B	B		
Pyridine	A	B	C	
Pyrol			B	
Quinine	A	A		
Rayon Coagulating Bath	A	B		
Resorcinol	A	B		
Ricine Oil	A		B	
Rinser Loosener	A	A	A	
Road Tar	U			
Roasting Gases	A	A		
Rouge	A	A		
Rubbers Dispersions/Latex	A	A		
Sagrotan	A	B		
Salicylic Acid	A	A	A	
Salicylic Acid Methyl Ester	A	B		
Sauerkraut	A	A		
Sea Water	A	A	A	A
Selenic Acid	A	A		
Shampoos, Shaving Lotion	A	A		
Shortening	A	B		
Silicic Acid	A	A		
Silicone Fats	A	A	A	
Silicone Oils	A	A	A	
Silver Nitrate ≤80%	A	A	A	B
Silver Salts, cold saturated	A	A	A	
Soap	A	A	A	
Soap Loosener	A	A	A	
Soap Solution	A	A	A	
Soda	see Sodium Carbonate			

Compound	Chemical Resistance				Compound	Chemical Resistance			
	40°C	60°C	80°C	100°C		40°C	60°C	80°C	100°C
Sodium Acetate	A	A	A		Sodium Perborate	A	C		
Sodium Aluminate	A	A	A		Sodium Perchlorate	A	A		
Sodium Aluminium Sulphate	A	A	A		Sodium Peroxide 10%	A	A	A	
Sodium Benzoate	A	A	A		Sodium Phosphate	A	A	A	
Sodium Benzoate to 36%	A	A	A		Sodium Polyacrylate (GR 894)	A	A	A	
Sodium Bicarbonate	A	A	A		Sodium Silicate	A	A	A	
Sodium Bisulphate	A	A	A		Sodium Sulphate	A	A	A	
Sodium Bisulphite	A	A	A	A	Sodium Sulphide	A	A	A	
Sodium Borate	A	A	A		Sodium Sulphite	A	A	A	
Sodium Bromide	A	A	A		Sodium Tetraborate	A	A	A	
Sodium Carbonate	A	A	A		Sodium Thiosulphate	A	A	A	
Sodium Chlorate	A	A	A		Soya Oil	A	B		
Sodium Chloride	A	A	A	A	Spermaceti	A	B		
Sodium Chlorite 50%	A	A	A	A	Spindle Oil	C	D		
Sodium Chlorite and Bleach	A		B		Spinning Oil	A		B	
Sodium Chlorite and Water	A	A	A	A	Spinning-Bath Oil containing Carbon Disulphide 0.01%	A	A		
Sodium Chromate	A	A			Spinning-Bath Oil containing Carbon Disulphide 0.07%	A	A		
Sodium Cyanide	A	A	A		Spot Solvents	A	A	A	
Sodium Dichromate	A	A			Stain Removers	C	D		
Sodium Dodecylbenzene Sulfonate	A	A			Stannic Chloride	A	A		
Sodium Ferricyanide	A	A	A		Stannic Salts	A			
Sodium Ferrocyanide	A	A	A		Stannous Chloride	A	A		
Sodium Fluoride	A	A	A		Starch	A	A	A	A
Sodium Hexacyano Ferrate	A	A			Starch Syrup	A	A	A	
Sodium Hexametaphosphate	A				Steam	A	A	A	
Sodium Hydrogen Carbonate	A	A	A		Stearic Acid	A	A	B	
Sodium Hydrogen Phosphate	A	A	A		Styrene	C	U		
Sodium Hydrogen Sulphite sol.	A	A	A		Succinic Acid	A	A		
Sodium Hydrosulphite 10%	A	A	A		Sucrose Solution	A	A	A	
Sodium Hydroxide 15%	A	A			Sugar	A	A		
Sodium Hydroxide 20%	A	A			Sulphates	A	A		
Sodium Hydroxide 30%	A	A			Sulphur	A	A	A	
Sodium Hydroxide 50%	A	A			Sulphur Dioxide, dry	A	A	A	B
Sodium Hydroxide 70%	A	A			wet, in water solution	A	A	A	
Sodium Hydroxide Conc. (Caustic Soda)	A	A			Sulphur Solution	A			
Sodium Hypochlorite 12%	B	D			Sulphur Trioxide	U			
Sodium Hypochlorite Solution	B				Sulphuric Acid 20%	A	A	A	A
Sodium Metaphosphate	A	A	A		Sulphuric Acid 50%	A	A	A	B
Sodium Nitrate	A	A	A		Sulphuric Acid 70%	A		C	
Sodium Nitrite	A	A	A		Sulphuric Acid 80-90%	A	A		
					Sulphuric Acid 96%	A			U

Compound	Chemical Resistance			
	40°C	60°C	80°C	100°C
Sulphuric Acid 98%	U			
Sulphuric Ether	B	C		
Sulphurous Acid	A	A		
Sulphuryl Chloride	B			
Superchloric Acid	see Perchloric Acid			
Synthetic Washing Powder, home quality	A	A	A	
Tallow	A	B		
Tannic Acid	A	A		
Tannin	see Ascorbic Acid			
Tar	U			
Tartaric Acid (Dihydroxy Succinic Acid)	A	A		
Tea	B	B		
Tertiary Butyl Alcohol	A	A	A	
Tetrabromo Ethane	D	U		
Tetrachloro Ethane	D	U		
Tetraethyl Lead	A			
Tetrahydro Furane	U			
Tetrahydro Furfuryl Alcohol	A			
Tetrahydro Naphtalene	B	U		
Tetraline	see Tetrahydro Naphtalene			
Tetramethylene Oxide	see Tetrahydro Furane			
Tin Chloride	A	A		
Tin Salts	A	A	A	
Thinner	D			
Thioglycolic Acid	A	A		
Thionyl Chloride	D	U		
Thiophene	D	U		
Titanium Tetrachloride	U			
Toluene	D	U		
Tomato Juice	A	A		
Transformer Oils	A	C	D	
Tributyl Phosphate	A	A		
Tributyl Ethyl Phosphate			B	
Trichloro Acetic Acid	A		B	
Trichloro Acetic Acid 50%	A	C		
Trichloro Benzene	U			
Trichloro Ethane	C		U	
Trichloro Ethylene (Tri)	U			
Trichloro Methane	see Chloroform			
Tricresyl Phosphate	A	A		
Triethanolamine	A	B		

Compound	Chemical Resistance			
	40°C	60°C	80°C	100°C
Triethylene Glycol	A	A		
Trifluoroacetic acid (TFA)	A			
Trilom, trade quality	A	A	A	
Trimethyl Borate	U			
Trimethylbenzene	see Pseudocumol			
Trimethylol Propane	A	A		
Trinitro Phenol	see Picric Acid			
Trinitro Toluene	U			
Trioctyl Phosphate	A	B		
Trisodium Phosphate	A	B	C	
Trybutyl Phosphate	A	A	A	
Turbine Oil			B	
Turpentine	D	U		
Tutogen U	A	A		
Tween 20	B	U		
Tween 80	B	U		
Urea	A	B		
Uric Acid	A	A		
Uric Compounds	see Carbamide			
Urine	A	A		
Urine, normal conc.	A	A	A	
Vanille Extract	A	B		
Vaseline	A	B	C	
Vaseline Oil	A		B	
Vegetable Dyes	A	A		
Vegetable Oils	B	B	B	
Vinegar	A	A	A	
Vinegar Acid Anhydride	A	A	B	U
Vinegar Acid Butyl Ester	see Butyl Acetate			
Vinegar Acid Ethyl Ester	see Ethyl Acetate			
Vinegar Ester	see Ethyl Acetate			
Vinegar, trading quality	A	A	A	
Vinyl Acetate	A	A		
Vinyl Chloride	A	A	A	
Vinyl Cyanide	see Acrylonitrile			
Viscose Spinning Solution	A	A		
Vitamin C	A	A		
Walnut Oil	A	B		
Waste gases with Acid	A	A		
Waste gases with Carbon Monoxide	A	A		
Waste gases with HCL	A	A		

Compound	Chemical Resistance			
	40°C	60°C	80°C	100°C
Waste gases with H ₂ SO ₄	A	A		
Waste gases with low Sodium Dioxide	A	A		
Waste gases with traces of Hydrogen Fluoride	A	A		
Waste gases with traces of Nitrosyl Sulfuric Acid	A	A		
Water	A	A	A	A
Water Acid Mine	A			
Water Deionized	A			
Water Distilled	A			
Water Glass	A			
Waxes	A	C		
Wetting Agents	A	B		
Whey	A	A		
Whisky	see Ethyl Alcohol			
Whitener	see Sodium Hypochlorite			
Wine Vinegar	see Vinegar			
Wine, red and white	A	A	A	
Wohlstone Acid	A	A	A	
Wood Glue, type Polyvinyl Acetate	B			
Wood Stains	A	C		
Wool Fat	see Lanolin			
See Xylol	C		U	
Yeast	A	A	A	
Zinc Bromide	A	A		
Zinc (II) Chloride	A	A	A	B
Zinc Carbonate	A	A	A	
Zinc Hydrate	A	A	A	
Zinc Oxide	A	A	A	
Zinc Salts	A			
Zinc Sludge	A	A		
Zinc Stearate	A	A		
Zinc Sulphate	A	A	A	

Classification

- A.** Resistant: can be used within the working pressures (safety factor of 1.25).
- B.** Conditionally resistant: restrictions of 70% to 90% must be made regarding the working pressures.
- C.** Conditionally resistant: can be used within pressures up to 60% of the working pressures.
- D.** Conditionally resistant: can be used within pressures up to 20% of the working pressures.
- U.** Unknown: not recommended.

In case of dangerous liquids (strong acids and bases) the safety factor should be increased to 1.5 or 2.0.

In case of doubt please consult us.

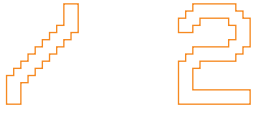

Design Considerations





Index

Water Hammer

Water Hammer Calculation for
Different Pipe Materials

Natural Bend Radius in Pexgol Pipes

Natural Bend in Pexgol Pipes

Vacuum/Suction Pipelines

Pexgol Pipes Design Considerations

Slurry Design Considerations

Inclined and Dewatering Pipes, High
Gradient Supply Lines

Design Guidelines for Complete
Systems

Design Considerations for Pexgol
Fittings

Abrasion Resistance

Water Hammer

Water hammer is a series of pressure pulsations, of varying magnitude, above and below the normal pressure of the liquid in the pipe. The amplitude and periodicity depends on the extinguished velocity of the liquid, as well as the size, length and material of the pipeline. Shock results from these pulsations when any liquid, flowing with a certain velocity, is stopped in a short period of time. The pressure increase, when flow is stopped, is independent of the working pressure of the system. The surge pressure in any pipeline occurs when the total discharge is stopped in a period of time, equal to or less than the time required for the induced pressure wave to travel from the point of valve closure to the inlet end of the line and return. This time is:

$$t = \frac{2L}{a}$$

Where:

t = Time for pressure wave to travel the length of the pipe and return (sec.)

L = Length of pipe line (m)

a = Velocity of pressure wave (m/sec)

When the liquid in the pipe is water, the velocity of the pressure wave "a" is determined by the following equation:

$$a = \frac{1440}{\sqrt{1 + 2070 \times \frac{d}{Ee}}}$$

Where:

a = Velocity of pressure wave (m/sec).

Kbulk = Bulk modulus of fluid (for example: 2,070 MPa for water at 20°C)

d = Inside diameter of pipe (mm)

e = Thickness of pipe wall (mm)

E = Instantaneous (short term) modulus of elasticity (MPa) for the pipe material (obtained from Tensile tests)

The surge pressure caused by water hammer is determined by the following equation:

$$P = 0.1 \times \rho \times a \times \frac{V}{g}$$

Where:

P = Surge pressure (bar)

ρ = Fluid density (for example: 1 gr/cm³ for water at 20°C)

a = Velocity of pressure wave (m/sec)

V = Velocity of water stopped = line velocity (m/sec)

g = Acceleration caused by gravity (9.81 m/sec²)

Pressure caused by water hammer can be minimized by increasing closure times of valves to a value greater than 2L/a.

For example, when the closure time is 10 times 2L/a, the pressure surge can be 10% - 20% of the surge caused by closure in a time equal to or less than 2L/a.

The value of the short-term modulus of elasticity E for Pexgol pipes is much lower than the value of E for steel pipes, concrete pipes or HDPE pipes. Since the velocity a of the pressure wave is related to the short-term modulus of elasticity E, the velocity a decreases when the value of E is lower.

In order to determine the resistance of the pipe material to the water hammer phenomenon, the total occurring pressure (surge pressure + working pressure) should be calculated and compared to the maximum allowable total occurring pressure in each pipe material. The resistance of HDPE pipes depends on the nature of the water hammer. In case of recurring water hammer shock waves, HDPE pipes are limited to a maximum total occasional pressure of only 1.5 times the working pressure. Because of the flexibility and resilience of Pexgol pipes, the surge pressures caused by the water hammer are much reduced. Furthermore, because of the cross-linked structure, the Pexgol pipe can withstand a total transient pressure (recurring or occasional surge pressure + working pressure) at least 2.5 times the design pressure in the relevant temperature.

Water Hammer Calculation for Different Pipe Materials

The following comparison examples show the pressure surges caused by the water hammer for various pipes, which are considered for the same application. In all following examples:

- The line is horizontal; line length is 2,200 m.
- The flow rate is 150 cubic metre per hour, head losses are 5%.
- The line is designed for a pump pressure of 11 bar.
- The fluid temperature: 20 °C

The pipes calculated for this application are as follows:

1. Steel pipe 6" schedule 40, buried pipeline or above-ground installation.
2. PE 3408 6" DR 11, buried pipeline.
3. PEX 160 mm SDR 13.6 Class 12, buried pipeline.
4. PE 4710 6" DR 13.5, buried pipeline.
5. PEX 180 mm SDR 11 Class 15, Above ground installation, ambient temperature 20°C, design temperature is 30°C.
6. PEX 180 mm SDR 9 Class 19, Above ground installation, ambient temperature 40°C, design temperature is 40°C.

1. Steel pipe 6" sch. 40

Buried pipeline or above ground installation.

OD: 6.625" (168.3 mm) | w.t. 7.11 mm | d = 154 mm | V = 2.2 m/sec | E = 210,000 MPa

$$a = \frac{1440}{\sqrt{1 + 2070 \times \frac{154}{7.11 \times 2.1 \times 10^5}}}$$

$$a = 1307 \text{ m/sec} \quad t = 2L/a = 2 \times 2200/1307 = 3 \text{ sec}$$

$$P = 0.1 \times 1307 \times \frac{2.2}{9.81} = 29 \text{ bar}$$

P = Surge pressure (bar) 29 bar.

Total transient pressure: Surge pressure (29 bar) + pump pressure in the line (11 bar) is 40 bar.

2. PE 3408 6" DR 11

Buried pipeline. Maximum allowable working pressure of the pipe is 11 bar (160 psi) at 20°C.

Maximum allowable total transient pressure: 16.5 bar (240 psi).

OD: 6.625" (168.3 mm) | w.t.: 0.602" (15.3 mm) | d: 137.7 mm | V = 2.8 m/sec, E = 827 MPa at 20°C

$$a = \frac{1440}{\sqrt{1 + 2070 \times \frac{137,7}{15,3 \times 827}}}$$

$$p = 0.1 \times 297 \times \frac{2,8}{9,81} = 8,5 \text{ bar}$$

$$a = 297 \frac{\text{m}}{\text{sec}}$$

$$t = \frac{2L}{a} = 2 \times \frac{2200}{297} = 15 \text{ sec}$$

P = Surge pressure (bar) 8.5 bar, total transient pressure: 11 + 8.5 = 19.5 bar.

Total transient pressure: Exceeds the maximum allowable total transient pressure for this pipe material.

3. Pexgol 160 mm SDR 13.6 Class 12

Buried pipeline: Maximum allowable working pressure of the pipe is 12 bar at 20°C. Maximum allowable total transient pressure: 30 bar.

OD: 160 mm | w.t.: 11.8 mm | d: 136.4 mm | V = 3 m/sec, E = 465 MPa at 20°C

$$a = \frac{1440}{\sqrt{1 + 2070 \times \frac{136,4}{11,8 \times 465}}}$$

$$p = 0.1 \times 199 \times \frac{3}{9,81} = 6 \text{ bar}$$

$$a = 199 \frac{\text{m}}{\text{sec}}$$

$$t = \frac{2L}{a} = 2 \times \frac{2200}{199} = 22 \text{ sec}$$

P = Surge pressure (bar) 6 bar, total transient pressure: 12 + 6 = 18 bar

Total transient pressure: Is much lower than the maximum allowable total transient pressure (30 bar).

4. PE 4710 6" DR 13.6

Buried pipeline: Maximum allowable working pressure of the pipe is 11 bar (160 psi) at 20°C.

Allowable total pressure during recurring surge is 16.5 bar.

OD: 6.625" (168.3 mm) | w.t.: 0.491" (12.5 mm) | d: 143.4 mm | V = 2.6 m/sec | E = 827 MPa at 20°C

$$a = \frac{1440}{\sqrt{1 + 2070 \times \frac{143,4}{12,5 \times 827}}}$$

$$p = 0.1 \times 264 \times \frac{2,6}{9,81} = 7 \text{ bar}$$

$$a = 264 \frac{\text{m}}{\text{sec}}$$

$$t = \frac{2L}{a} = 2 \times \frac{2200}{264} = 17 \text{ sec}$$

P = Surge pressure (bar) 7 bar, total transient pressure: 11 + 7 = 18 bar.

Total transient pressure: Exceeds the maximum allowable total transient pressure for this pipe material.

5. Pexgol 180mm SDR 11 Class 15

Above ground installation: ambient temperature is 20°C, design temperature is 30°C. Maximum allowable working pressure of the pipe is 13 bar (193 Psi) at 30°C. Maximum allowable total transient pressure: 30 bar.

OD: 180 mm | w.t.: 16.4 mm | d: 147.2 mm | V = 2.5 m/sec | E = 350 MPa at 30°C

$$a = \frac{1440}{\sqrt{1 + 2070 \times \frac{147.2}{16.4 \times 350}}}$$

$$P = 0.1 \times 195.8 \times \frac{2.5}{9.81} = 5 \text{ bar}$$

$$a = 195.8 \frac{\text{m}}{\text{sec}}$$

$$t = \frac{2L}{a} = 2 \times \frac{2200}{195.8} = 22 \text{ sec}$$

P = Surge pressure (bar) 5 bar, total transient pressure: 13.3 + 5 = 18.3 bar

Total transient pressure: Is much lower than the maximum allowable total transient pressure (30 bar).

6. Pexgol 180 mm SDR 9 Class 19

Above ground installation: ambient temperature is 40°C, design temperature is 40°C. Maximum allowable working pressure of the pipe is 11 bar at 40°C. Maximum allowable total transient pressure: 30 bar.

OD: 180 mm | w.t.: 20 mm | d: 140 mm | V = 2.7 m/sec | E = 228 MPa at 40°C

$$a = \frac{1440}{\sqrt{1 + 2070 \times \frac{140}{20 \times 228}}}$$

$$P = 0.1 \times 180 \times \frac{2.7}{9.81} = 5 \text{ bar}$$

$$a = 180 \frac{\text{m}}{\text{sec}}$$

$$t = \frac{2L}{a} = 2 \times \frac{2200}{180} = 24 \text{ sec}$$

P = Surge pressure (bar) 5 bar, total transient pressure: 11 + 4 = 15 bar

Total transient pressure: Is much lower than the maximum allowable total transient pressure (30 bar).

Conclusions

1. The surge pressure caused by the water hammer in steel pipes is at least three times higher than the surge pressure in Pexgol pipes.
2. The surge pressure caused by the water hammer in HDPE pipes could sometimes be too high.
3. Pexgol pipes have a high margin for surge pressures in all temperature range and pipe classes.

The expression for a = the velocity of pressure wave is a function of the short term Modulus E and the dimension ratio d/e, which is the same for each pipe class:

$$d/e = (D - 2xe)/e = (D/e) - 2 = \text{SDR} - 2$$

It is possible to calculate the values for a for each pipe class.

In the following table (32.1), the values of the pressure velocity a were calculated for the following design temperatures:

- 20°C – for buried pipes
- 30°C – for above ground pipes at ambient temperature of 20°C
- 40°C – for above ground pipes at ambient temperature of 40°C

The values of P were calculated for line velocity of 1.0 m/sec.

Table 48.1 shows the low surge pressures expected in Pexgol pipes.

Table 48.1: Surge pressures in Pexgol pipes (according to water velocity of 1 m/sec)

Pipe Class	SDR	E = 465 MPa		E = 350 MPa		E = 228 MPa	
		20 °C		30 °C		40 °C	
		a [m/sec]	Surge pressure [bar]	a [m/sec]	Surge pressure [bar]	a [m/sec]	Surge pressure [bar]
6	26	139	1.4	120	1.2	97	1.0
8	21	156	1.6	135	1.4	109	1.1
10	16.2	180	1.8	156	1.6	126	1.3
12	13.6	198	2.0	173	1.8	140	1.4
15	11	225	2.3	196	2.0	158	1.6
19	9	254	2.6	221	2.3	179	1.8
24	7.4	288	2.9	251	2.6	204	2.1
30	6	332	3.4	290	3.0	236	2.4

2023

The value of a = Velocity of pressure wave was calculated using the instantaneous **Modulus of Elasticity**. Please note the surge pressure P is in direct linear relation to the value of the line velocity V .

Therefore, values for different surge pressures for the same pipe class can be calculated by changing the values of the Line velocity V .

Example: Calculating the surge pressure in paragraph 4. Pexgol 180 mm SDR 9 Class 19.

- Above ground installation ambient temperature is 40°C.
- Fluid temperature is 20°C
- Design temperature is 40°C.
- Design pressure of the pipe is 14.9 bar at 40°C.
- Maximum allowable total transient pressure is 37 bar.

OD 180 mm | **w.t.** 20.1 mm | **d** = 139.8 mm | **V** = 2.7m/sec.
From the table: "Low surge pressures in Pexgol pipes", the

surge pressure for class 19, velocity of 1 m/sec and design temperature of 40°C is 1.8 bar.

For the Pexgol 180 mm class 19 which has a velocity of 2.7 m/sec, the surge pressure will be: $1.8 \times 2.7/1 = 4.9$ bar

For water density higher than 1.0, divide the value of the Velocity of the pressure wave a (taken from Table 48.1: "Low surge pressures in Pexgol pipes") by the square root of the actual water density.

For fittings on the line please contact the Pexgol team.

Technical Information

Natural Bend Radius in Pexgol Pipes

To create turns with Pexgol pipes laid inside trenches, above the ground or over pipe bridges, the pipe can be bent according to table 50.1 "Natural bending radius".

The values in Table 49.1 "Natural bending radius" are relevant for installations at all ambient temperatures up to 40°C.

For pipe diameters lower than 110 mm use the values of the 110 mm pipes at all pressure classes.

Field bending involves excavating the trench to the appropriate bend radius, then sweeping or pulling the pipe string into the required bend and placing it in the trench.

This kind of pipeline design, which takes advantage of the natural flexibility of the pipe, reduces the number of connections and lowers head losses.

Observe appropriate safety precautions during field bending. Considerable force might be required to field bend the pipe, and the pipe could spring back forcibly if the restraint slips are inadvertently released while bending.

Designing Pexgol Pipes with Natural Bends

When designing Pexgol pipes with natural bends, it is recommended to consult with our field service personnel. Take into consideration that to bend the pipe on site, suitable facilities are required. Take into consideration the space required to insert the pipe into the construction, as well as the possibility to exert bending moment of the pipe..

"Natural" bends of Pexgol pipes

Table 50.1 shows bending radius for Pexgol pipes. If possible, design the pipeline with larger bending radii to facilitate pipe bending on site.

The pipe bends must be fixed with fixpoint clamps before and after each elbow. For pipe diameters of 280 mm and larger, the pipe bends must be supported in the centre in addition to the two fix points noted. For additional details please contact the Golan's application engineer.

Route change of Pexgol pipes inside trenches

For a route change in buried pipes, it is recommended to dig the trench with the minimum natural bending radius listed in Table 49a.1.

Table 49.1: Natural Bending Radius

Pipe OD	Class 6	Class 8	Class 10	Class 12	Class 15	Class 19	Class 24	Class 30
110	13.5D	10.5D	8D	6.5D	5D	4.5D	3.5D	3D
125	16.5D	13.5D	10D	8.5D	6.5D	5.5D	4.5D	3.5D
140	16.5D	13.5D	10D	8.5D	6.5D	5.5D	4.5D	3.5D
160	16.5D	13.5D	10D	8.5D	6.5D	5.5D	4.5D	3.5D
180	16.5D	13.5D	10D	8.5D	6.5D	5.5D	4.5D	3.5D
200	16.5D	13.5D	10D	8.5D	6.5D	5.5D	4.5D	3.5D
225	16.5D	13.5D	10D	8.5D	6.5D	5.5D	4.5D	3.5D
250	20D	16D	12D	10D	8D	6.5D	5D	4D
280	20D	16D	12D	10D	8D	6.5D	5D	4D
315	27D	21.5D	16D	13.5D	11D	8.5D	7D	5.5D
355	27D	21.5D	16D	13.5D	11D	8.5D	7D	5.5D
400	34D	27D	20D	17D	13D	10.5D	8.5D	7D
450	34D	27D	20D	17D	13D	10.5D	8.5D	7D
500	40D	32D	24D	20D	16D	13D	10D	8D
560	43D	34.5D	26D	22D	17D	13.5D	11D	9D
630	47D	37D	28D	23.5D	19D	14.5D	12D	9.5D
710	50D	40D	30D	25D	20D	16D	13D	10D

Natural Bends in Pexgol Pipes

When designing and installing Pexgol pipes in natural bends, high bending moments might be exerted upon the end connectors.

In case of self-restrained fittings no special care should be taken. In case of non-restrained fittings, special care should be taken to prevent excessive bending moment on the end-connectors due to forced installation.

See page 104 (Non-Restrained Fittings and Pullout Prevention Techniques).

Bending the Pipes

Use a suitable device, such as a winch or a lever, to bend the pipes. Remember that the pipe is rigid and considerable force is required for bending and fixing it – for example, 2 tons for a 110 mm pipe and 5 tons for a 280 mm pipe. Please exercise caution.

Bend the pipe carefully to avoid kinking. For best results, it is recommended to prepare a continuous pipe support with the radius of the pipe to be bent.

Then bend the pipe against it.

The installation is complicated since it is difficult to calculate in advance the exact length of the pipe. As a result, on-site adaptation (field welding) is necessary.

Proper Installation Procedure

1. Since the longer leg is more flexible, it is advised to connect the shorter leg to the existing counter-flange.

2. If necessary, install a fixpoint clamp before the fitting to protect it during bending.

3 If the fitting is an electrofusion fitting, wait three cooling times (3x) before continuing with the next step.

4. Adjust the length of the longer arm.

5. Cut the length and install the fitting.

5.1 If the fitting is an electrofusion fitting with a stub-end (flared end) connection, perform the welding when the flared end is free (not connected to the counter-flange). Connect the flared end & flange to the counter-flange only after waiting three cooling times (3x).

5.2 If the fitting is an electrofusion fitting which connects the longer arm to another Pexgol or PE pipe, install a temporary fixpoint bridge before welding in order to protect the electrofusion fitting during welding. Disassemble the

temporary fixpoint bridge only after waiting three cooling times (3x).

5.3 See Non-restrained fittings on page 100.



Vacuum/Suction Pipelines

Negative-pressure (vacuum) might develop in the following cases:

1. When a pipe is installed in vacuum-feeding pipelines.
2. When a pipe is installed in a steep inclination, causing rapid free flow.
3. Extreme temperature changes of the transported liquid.

If a Pexgol pipe collapses, it results in an oval deformation. Note that when a Pexgol pipe collapses due to vacuum,

it can be returned to its original round shape by applying internal pressure.

The amount of vacuum that a Pexgol pipe can withstand depends on the pipe's SDR. A pipe with sufficient wall thickness must be selected in order to resist the collapsing forces generated by the vacuum.

Table 51.1 shows maximum rates of vacuum supported by Pexgol pipes of different classes and different design temperatures. These are values empirical values.

Table 51.1: Service under Vacuum

Pipe Class	SDR	Temperature	1 Year	50 Years
30	SDR 6	up to 80°C	Full vacuum *	
24	SDR 7.4	up to 80°C	Full vacuum *	
15	SDR 11	up to 80°C	Full vacuum *	
12	SDR 13.6	20 °C	Full vacuum *	
12	SDR 13.6	60 °C	-0.9	-0.8
10	SDR 16.2	60 °C	-0.65	-0.6
8	SDR 21	60 °C	-0.52	-0.5
6	SDR 26	60 °C	-0.45	-0.4

* Tested under full vacuum conditions: -1 bar (g) 0 bar (a)

The values in the table are in bar (g) (Bar gauge). For example:

-0.8 bar (g) is equal to 0.2 bar (a) or Bar absolute

Pexgol pipe class 10 is not recommend for use under full vacuum conditions.

Allowable External Pressure

For pipe of uniform cross-section, applying a safety factor of 1.5 which includes the influence of pipe ovality, the maximum allowable external pressure P_c in bar can calculated from the following equation:

$$P_c = 2618 / (SDR - 1)^3$$

Pexgol Class 10 SDR 16.2	$P_c = 0.75$ bar
Pexgol Class 12 SDR 13.6	$P_c = 1.0$ bar
Pexgol Class 15 SDR 11.0	$P_c = 2.5$ bar
Pexgol Class 19 SDR 9.0	$P_c = 5.0$ bar
Pexgol Class 24 SDR 7.3	$P_c = 10.0$ bar
Pexgol Class 30 SDR 6.0	$P_c = 21.0$ bar

Underground Pexgol Pipe under Vacuum or External Pressures

Vacuum, or external pressures, creates hoop stresses in the pipe wall which are combined with the external pressures of the soil. In extreme cases, these stresses can cause the pipe to collapse. Therefore, when a Pexgol vacuum pipeline is installed underground, the vacuum stresses have to be added to the total static and dynamic loads exerted by the soil and all the stresses must be considered.

In this case, make sure that the soil around the pipe is compacted. When designing a vacuum pipeline at recommended vacuum conditions, please contact our engineer for consultation regarding installation of vacuum breakers.

Pexgol Pipes Design Considerations

The values of the design stresses vary according to the design temperatures. These values are shown in the Table 9.2 "Allowable working pressures [psi] for conveying water in Pexgol pipes".

1. Defining the Design Temperature

The design temperature of the Pexgol pipe is calculated based on the data from the RFI questionnaire.

In case of insulated / buried pipes, the design temperature is equal to the fluid temperature.

In case of above-ground installation:

1. Pipe above ground, exposed to direct sunlight - the design temperature of the Pexgol pipe is to be calculated as the mean value between the TEX (temperature of the external pipe surface) and TFL (fluid temperature). The temperature of the external pipe surface is calculated as 20°C above the ambient temperature:
TEX = T. ambient + 20°C
2. Pipe above ground, not exposed to direct sunlight – The temperature of the external pipe surface (TEX) is equal to the ambient temperature.

To facilitate the calculation see the following table.

Fluid Temperature °C	Surface Temperature (TEX)					
	20	30	40	50	60	70
	Design Temperature					
20	20	25	30	35	40	45
30	25	30	35	40	45	50
40	30	35	40	45	50	55
50	35	40	45	50	55	60
60	40	45	50	55	60	65

Example:

Fluid temperature 20°C

Ambient temperature: 40 °C

TEX=40+20=60°C

Design temperature is (60+20)/2= 40°C

2. Water and Newtonian fluids

The pipe SDR is selected according to the following data from the RFI questionnaire:

Pressure head losses in the line expressed in bars (taking into account the specific gravity of the transported material).

Design temperature (see first paragraph above).

Basic safety factor (design coefficient):

- 1.25 for water and fluids with the classification A in the chemical resistance list.

- For materials with classification B, C, D in the chemical resistance list, please consult Golan.
- 1.5 for air supply lines.

Static pressure according to the altitude difference in the line and the specific gravity of the transported material.

If the pipeline is horizontal and the static pressure is low, select class 6 and verify its suitability.

Choose a higher class with the same OD in order in to increase the transportable section lengths.

The hydraulic calculation usually results in the same OD.

If the altitude difference in the line is significant, select a Pexgol pipe class that has in the design temperature higher pressure rating than the static pressure. The additional pressure margin is used for the pressure head losses; this will determine the ID of the pipe.

The OD is determined according to pipe ID and Class requirement.

3. Replacing Waterline Steel Pipes

When replacing steel pipes (Hazen - Williams C = 110) with Pexgol pipes (Hazen - Williams C = 155) with the same pressure head losses, the ID of the Pexgol pipe can be 88% of the ID of the existing steel pipe.

When replacing steel pipes with Pexgol pipes with the same ID, the head losses are expected to be lower by 50%.

4. Influence of Temperature Changes on Pexgol Pipes

Pexgol pipes placed above the ground or over bridges tend to get longer (to expand) when temperature rises (snaking

phenomenon) or to get shorter (contract) as the temperature decreases. Expansion or contraction does not affect the Pexgol pipe, even in extremely low temperatures.

There is no need to protect the pipe against thermal stresses, as they are absorbed by the pipe.

Fixpoints or guiding clamps are used for restraining the elongation of the pipe (mainly for aesthetic considerations).

There is no need for installation of "expansion joints" or omegas to protect the Pexgol pipe.

In some cases, special fixpoint clamps should be used before and after the fittings (as recommended) to prevent the pipe from pulling out. These cases are specify in page 61.

5. Pexgol pipes above ground

Pexgol pipes withstand exposure to sunlight for unlimited periods - that is, the lifetime of the pipe.

- Pexgol pipes can be placed directly on ground.
- Special bedding is not required.
- For further information see: Above ground installation guidelines.

6. Pexgol pipes at low temperatures

Pexgol pipes are used at temperatures as low as -50°C and even lower. Since the Pexgol material does not become brittle at these temperatures, it tolerates bending and dragging at low temperatures during installation.

Pexgol pipes tolerate complete "homogeneous" freezing of the transported liquid. Homogeneous freezing takes place if the pipe is evenly exposed to low temperatures along the pipeline.

However, if freezing starts at localised freezing points, the pressure of the fluid which is trapped between two adjacent freezing points increases until the pipe bursts.

This happens to any pipe material. Localised freezing points might be metal fittings (including Pex-lined steel fittings), fixpoint clamps or any point where the metal touches the pipe. Consequently, localised freezing points should be avoided or properly insulated. Please note that this applies to both above-ground or shallow underground installations.

Table 53.1: Replacing Carbon steel slurry pipes with Pexgol pipes (by matching internal diameter)

Sch. 40 Carbon steel pipe		Option 1	Loose flanges	Option 2	Loose flanges
Size	ID (mm)				
3"	78	90 class 15	3"	110 class 24	4"
3 1/2"	90	110 class 15	4"	125 class 24	4"
4"	102	125 class 15	4"	140 class 24	5" or 6"
5"	128	160 class 15	6"	180 class 24	6"
6"	154	180 class 15	6"	200 class 24	8"
8"	202	250 class 15	10"	280 class 24	10"
10"	254	315 class 15	12"	355 class 24	14"
12"	303	355 class 12	14"	-	-
14"	333	400 class 15	16"	450 class 24	18"
16"	381	450 class 12	18"	-	-
18"	428	500 class 12	20"	-	-

Slurry Design Considerations

1. The pipe class is determined based on the following data from the RFI Application Questionnaire:

- Working pressures
- Design Temperature
- Chemical resistance of the pipe material to the slurry

2. The pipe diameter is chosen based on the ID of existing steel pipe or on the value of the minimum critical slurry velocity.

3. Replacing carbon steel slurry pipes with Pexgol pipes with the same ID: A slurry pipeline is designed according to the minimum critical velocity of the slurry material. Carbon steel slurry pipes can be replaced with Pexgol pipes of the same or slightly smaller nominal ID, maintaining the same slurry velocity.

4. Pexgol pipes have an "abrasion allowance" of 20% of the nominal wall thickness of the pipe. This means that the pipe can withstand the design working pressure until the remaining wall thickness of the pipe is reduced to 80% of the nominal value. The real lifetime of the pipe depends on the actual abrasion rate in the line. The 80% rule applies for all working pressures and all temperatures in all classes.

Inclined and Dewatering Pipes, High Gradient Supply Lines

Design Considerations

- All these type of pipes should be axially restrained at the top and bottom of the line.
- The pump rests on the ground. The weight of the pump and water column is not supported by the pipe.

Defining the Design Temperature

See Point 1 of "Pexgol Pipes design considerations"

Selecting the Pexgol pipe for dewatering/uphill pipes

Design example:

Required flow rate: 150 cubic metres per hour
Pipeline goes from an altitude of 2100 m to an altitude of 2235 m.

Line length: 500 m

Ambient temperature: 40 °C

Fluid temperature: 20 °C

The pipe can be installed above ground or covered by 0.9 m of soil.

Calculate the line pressure by grade line calculation or according to any other applicable method.

Calculate the static pressure at the lowest point of the pipeline taking into account the fluid density. For water, multiply the altitude difference (in metres) in the line by 10. The result is in bar. Please note that the lowest point is not necessarily at the bottom of the pipeline.

In this example:

$$2235 - 1100 = 1135 \text{ m}$$

$$1135 = 11.35 \text{ bar}$$

Choose the appropriate Pexgol pipe class from Table 11.2 by looking at the design temperature. Select the Pexgol pipe class which has a higher working pressure than the calculated value in section 3.1. The additional pressure margin will be used for the head losses.

For design temperature for above ground installation please see "Defining design temperature".

Selected pipe class for buried pipes installation:

Class 19. Working pressure - 14.9 bar at 40°C:

Selected pipe class for above ground installation:

Class 24: Working pressure - 15 bar at 60°C.

Alternative pipe - Class 30. Working pressure -

18.9 bar at 60°C. Design temperature for buried pipes is 40°C.

Design example with alternative pipe class 24

Calculate the pressure margin and the allowable head

losses coefficient J;

Pressure margin for above ground installation is

$$15 - 13.5 = 1.5 \text{ bar} = 15 \text{ m}$$

$$J = 15 \times 100/500 = 3\%$$

Pressure margin for the alternative pipe for above ground installation is:

$$18.9 - 13.5 = 5.4 \text{ bar} = 54 \text{ m}$$

$$J = 54 \times 100/500 = 10.8\%$$

Pressure margin for buried pipes installation

$$14.9 - 13.5 = 1.4 \text{ bar} = 14 \text{ m}$$

$$J = 14 \times 100/500 = 2.8\%$$

Pressure margin for the alternative pipe for buried pipes installation:

$$18.7 - 13.5 = 5.2 \text{ bar} = 52 \text{ m}$$

$$J = 52 \times 100/500 = 10.4\%$$

Select the pipe diameter according to the calculated J and the flow rate.

The selected pipe diameter for above ground installation is 200 class 24.

The alternative pipe diameter for above ground installation is 180 class 30.

The selected pipe diameter for buried pipe installation is 200 class 19.

The alternative pipe diameter for buried pipe installation is 160 class 24.

Advantages of the alternative pipes:

- Smaller diameters allow transportation of longer pipe sections that results in cheaper transportation.
- Cheaper pipe per metre length.
- Disadvantage: higher head losses.

The line designer should include in the line the all the required accessories including air relief valves and drain valves.

If the overall altitude difference in the line is much higher than the maximum allowable altitude difference H of the highest Pexgol SDR available, the line should be designed using booster pumps.

Selecting the Pexgol pipe for a downhill pipeline using a full cross-section flow design. In a full cross-section flow design the pipe has to support the full static pressure (liquid column) of the line.

Design example:

The pipeline goes down a slope from an altitude of 2250 m to an altitude of 2100 m.

Required flow rate: 150m³ per hour

Line length: 1500 m

Fluid temperature: 20 °C

Ambient temperature: 40 °C

The pipe can be installed above ground or covered by 0.9 m of soil.

Calculate the line pressure by grade line calculation or according to any other method. Calculate the static pressure at the lowest point of the pipeline taking into account the fluid density. For water – divide the altitude difference (in

metres) in the line by 10. The result is in bar. Please note that the lowest point is not necessarily at the bottom of the pipeline. In this example the lowest point in the line is located at the end of the line:

$$2250 - 1100 = 150 \text{ m} = 15.0 \text{ bar}$$

Choose the suitable Pexgol pipe class from Table 11.2: "Allowable working pressures [bar] for conveying water in Pexgol pipes" by looking at the design temperature. Select the Pexgol pipe class which has the same or slightly higher working pressure than the calculated value in section.

Design temperature for above ground installation is $40^{\circ} + 20^{\circ}\text{C}$. Selected pipe class for above ground installation:

For a full cross-section flow design the pipe should be Pexgol class 24 in order to allow a working pressure of 15 bar at 60°C .

Calculate the allowable head losses coefficient J based on the altitude difference in the line and the line length: Altitude difference is: 150 m $J = 150 \times 100/1500 = 10\%$

For a full cross-section flow design, select the suitable pipe that can transport the required flow with the calculated value of J. Selected pipe SDR for above ground installation is 160 class 24. Selected pipe class for buried pipe installation is 160 class 19.

Check the value of the expected surge pressure (water hammer) against the maximum permissible. Total occasional pressure, which is 2.5 the working pressure in the design temperature.

For the 160 class 24, the Line velocity $V = 4 \text{ m/sec}$. According to the Table 32.1: "Low surge pressures expected in Pexgol pipes" the surge pressure for class 24 is 3 bar for $V = 1 \text{ m/sec}$. for $V = 4 \text{ m/sec}$. the surge pressure value will be $4 \times 3 = 12 \text{ bar}$.

The total occasional pressure will be $15 + 12 = 27 \text{ bar}$. The maximum permissible total occasional pressure in class 24 at 60°C is $15 \times 2.5 = 37.5 \text{ bar}$.

Conclusion: the 160 class 24 is O.K. or the 160 class 19, the line velocity $V = 3.44 \text{ m/sec}$.

According to the Table 32.1: "Low surge pressures expected in Pexgol pipes", the surge pressure for class 24 is 3.2 bar for $V = 1 \text{ m/sec}$ so for $V = 3.44 \text{ m/sec}$ the surge pressure value will be $3.44 \times 3.2 = 11 \text{ bar}$. The total occasional pressure will be $15 + 11 = 26 \text{ bar}$. The maximum permissible total occasional pressure in class 19 at 40°C is $14.9 \times 2.5 = 37.25 \text{ bar}$. **Conclusion:** the 160 class 19 is O.K.

Air Relief Valves

Air relief valves are required in any pipeline material including Pexgol.

The line designer should specify all the required accessories including air relief valves and drain valves.

As a service to our customers, Pexgol application engi-

neers can perform the analysis of the line in cooperation with A.R.I. Israel and supply a drawing with the location of the air relief valves. Golan supplies the air relief valves and the saddles/fittings required for connecting the line accessories to the Pexgol pipes.

The following data is required for the analysis:

1. List of key points along the line in Excel file or PDF/DWG drawing of the line with the following details:

- Name of the point.
- Location of the point: distance from the beginning of the line and height above a reference point.
- Type and functionality of each fitting: drain, cut-off valve, pressure reducer, outlet connection to consumer (indicate flow rate), etc.

2. Working conditions:

- Flow direction
- Discharge rate
- Inlet/outlet pressures

Selecting the Pexgol pipe for downhill single slope pipeline using a partially filled cross-section flow design

Please note that this type of design requires a skilled designer so the following information should be considered as guidelines only.

- In case of a partially filled cross-section flow design, the pipe is to be designed so that it will be in a low pressure (close to an atmospheric pressure) in all or most of its length. This design allows the use of a lower pipe class of with a larger OD and this might be problematic for transportation.

Calculate the allowable head losses coefficient J based on the altitude difference in the line and the line length.

Calculate the ID of the pipeline (according to Hazen – Williams $C = 155$ or any other formula).

In order to make sure that flow regime will be a partially filled cross-section, the selected actual ID of the line should be at least 25% higher than the calculated pipe ID according to previous design example.

Selecting the Pexgol Pipe Class: It is a good practice to design Class 15 in order to allow full vacuum resistance and the possibility of transporting long pipe sections. Lower pipe classes should be avoided in this case. Higher pipe classes can be designed for transporting longer sections while maintaining the required minimum ID for the partially filled cross-section low design.

Pexgol pipe for downhill single slope pipeline can be designed using a partially filled cross-section flow design

Each top point in the line should be vented so that the pressure there is atmospheric pressure.

Each valley is actually a siphon so that the height of the fluid column above the bottom of the valley is calculated

from the previous top point in the line.
 In some cases, the pipe class might have to be higher than class 15, depending on the local static pressure.

Installing the Pexgol pipe

Pexgol pipes can be towed upwards from the bottom of the line or it is possible to slide the pipe down from a high point.

Empty Pexgol pipes can be towed up to the top of the line in very long sections. Table 57.1 presents the maximum allowable length of an empty Pexgol pipe that is allowed to be towed or slid to its final location, depending on the design temperature.

The maximum allowable length is the same for all Pexgol pipe classes.

The required towing force can be calculated by multiplying the weight of the pipe by the friction coefficient of 0.5. If the pipe consists of more than one sections, the sections

can be connected temporarily during towing.
 If the pipe sections are already connected by fittings, they should be secured and protected by fixpoint bridges.

Securing inclined Pexgol Pipes

- The top and bottom ends of the Pexgol pipeline should be anchored by a fixpoint (see drawing).
- The Pexgol pipeline can be laid uphill or downhill in a long continuous section, without any fixpoint between the top and bottom ends.
- There is no limitation on the total pipe length.
- It is recommended to design the pipe with an additional 1 - 2% slack in order to reduce potential axial contraction forces.
- The weight of the pipe might increase due to accumulation of soil or snow on top of it. This additional weight will be balanced by the increasing friction between the pipe and the ground.

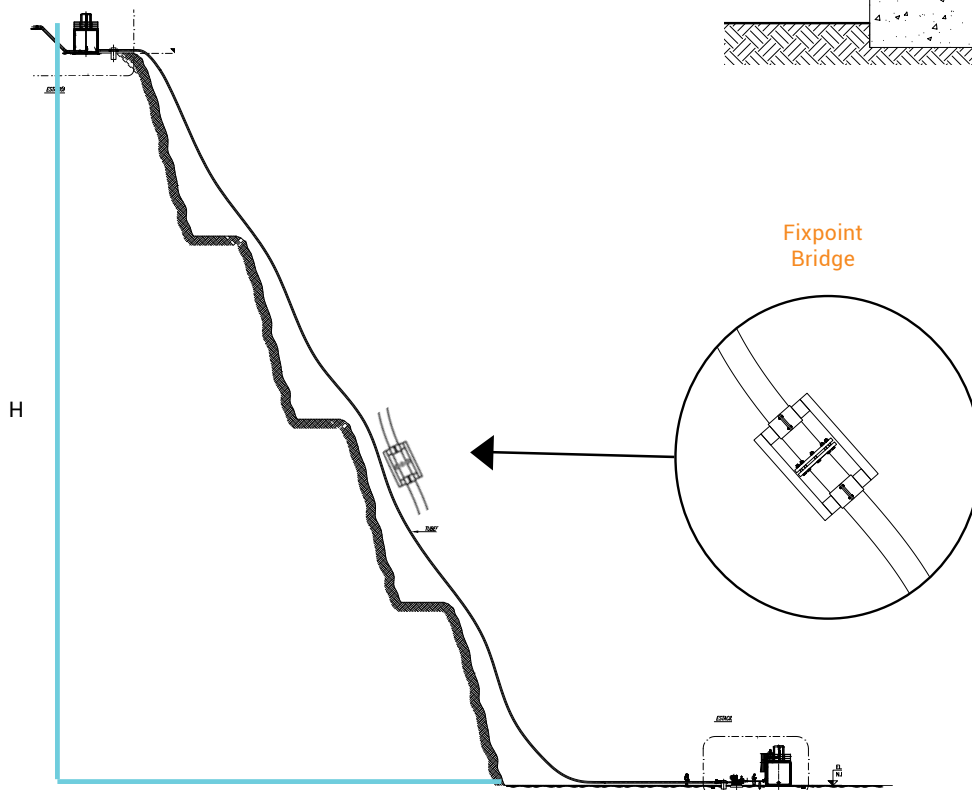
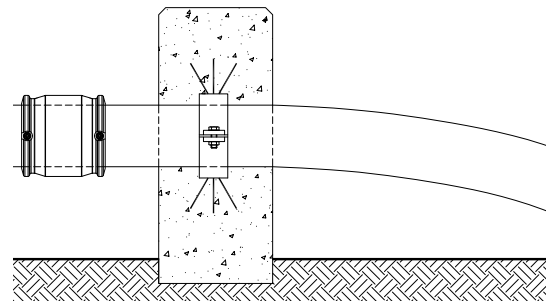

Table 57.1: Towing of empty Pexgol pipe - maximum allowable length (metres)

Pipe	0 °C	10 °C	20 °C	30 °C	40 °C	50 °C	60 °C
All Classes	1150	1100	1000	850	750	650	600

Restraining of Fittings along the Pipeline

- In slopes of less than 40°, all mechanical couplers (flared ends, flange couplers etc.) should be restrained by floating fixpoint devices like Golan's fixpoint bridge (page 134). Electrofusion couplers can be installed without a floating fixpoint device.
- In slopes above 40°, all type of fittings (including electrofusion couplers) should be restrained by floating fixpoint devices.
- When installing a repair fitting, the pipe can be secured by a fixpoint bridge prior to cutting the pipe.

Air Relief Valve Analysis example (Courtesy of ARI)

Elevation

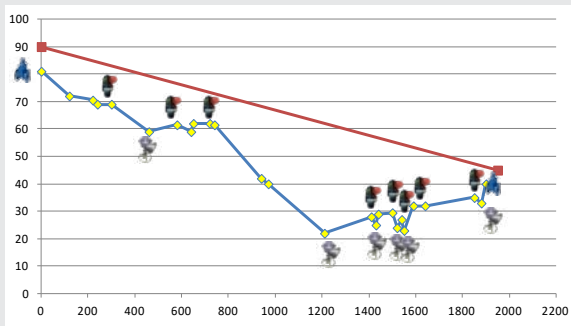

Distance

Isolating valve
 Drainage valve
 Air relief valve

Ection Diameter: 164 / Pipe Material: 150, Maximum Negative Pressure: 4			
0+000	0.00	80.84	Reservoir / Water tower Flowrate: 170.00, Water level: 90.00 Isolating valve Diameter: 200.00, Head loss: 0.70 D-040 Selected diameter: 2
0+290	290.00	69.20	D-040 Selected diameter: 2
0+470 Drainage Valve	470.00	58.80	Drainage valve Diameter: 50.00, Head loss: 0.60
0+570	500.00	61.50	D-040 Selected diameter: 2
0+720	720.00	61.93	D-040 Selected diameter: 2
1+210 Drainage Valve	1,210.00	22.60	Drainage valve Diameter: 50.00, Head loss: 0.60
1+410	1,410.00	27.70	D-040 Selected diameter: 2
1+430 Drainage Valve	1,430.00	25.50	Drainage valve Diameter: 50.00, Head loss: 0.60
1+500	1,500.00	29.41	D-040 Selected diameter: 2
1+520 Drainage Valve	1,520.00	24.60	Drainage valve Diameter: 50.00, Head loss: 0.60
1+540	1,540.00	27.65	D-040 Selected diameter: 2
1+550 Drainage Valve	1,550.00	24.09	Drainage valve Diameter: 50.00, Head loss: 0.60
1+590	1,590.00	31.65	D-040 Selected diameter: 2
1+850	1,850.00	34.59	D-040 Selected diameter: 2
1+880 Drainage Valve	1,880.00	32.57	Drainage valve Diameter: 50.00, Head loss: 0.60
1+900	1,900.00	40.47	D-040 Selected diameter: 2

Design Guidelines for Complete Systems

Designing a Complete Solution by GPP.

For every application received from a customer, we must have the Application RFI Questionnaire and the relevant assembly drawings of the pipeline. We design the pipe class and recommend the complete solution.

The detailed assembly drawing of the proposed solution is sent to the client for approval. We transform the approved version into parts drawings and prepare a price quotation.

1. Elbows

- 1.1 If possible, use Pexgol straight pipes with a natural bend (see page 50). Pexgol pipes come in straight sections in maximum length of 11.8 metres. They are available with one or two flared ends and flanges. If you have to bend a pipe with a longer length, order two sections and make a longer pipe by connecting it with an electrofusion coupler.
- 1.2 When straight pipe sections with the natural bend is not an option, use Pexgol elbows.
- 1.3 Please note that our elbows are significantly longer than the carbon steel elbows.
- 1.4 3 x D elbows are recommended rather than 1.5 x D since 3 x D elbows reduce head losses and abrasion rate.
- 1.5 Other non-standard angles are available by special order.
- 1.6 If there is not enough space for Pexgol elbows, you can specify Pex-lined steel elbows, (Pex-lined fittings, see page 110).

2. Other fittings

- 2.1 The following items, in addition to straight pipe sections and elbows, can be supplied from Pexgol material: concentric or eccentric reducers and instrument Tees.

3. PE-X lined steel fittings

- 3.1 Components in the line which are not straight pipes or elbows including steel tees, laterals, and others, can be designed as PE-X lined steel fittings. Choose standard items from our Fittings Catalogue, page 161.
- 3.2 However, if you find that you need to make a non-standard item with longer or shorter legs, make your selection and ask GPP for approval.

- 3.3 The maximum length of any item is approximately 2200 mm x 2200 mm.
- 3.4 The standard items come with fixed flanges.
- 3.5 When PE-X lined steel fittings are connected to Pexgol pipes or elbows, the ID of the PE-X lined steel fittings can be larger than the ID of the Pexgol pipe with the same flange size. In order to match up their ID, smaller size fittings with the same flange sizes as the flanges of the pipes can be used. Please consult us.

4. Expansion joints & Omega loops

- 4.1 Expansion joints and Omega loops are not necessary. However, expansion joints might be needed to protect other fittings such as carbon steel lined fittings.

5. Influence of temperature changes on pipeline length

- 5.1 The length of Pexgol pipes can be changed by 0.3% due to a temperature change of 20°C, meaning 3 mm for every 1 metre.
- 5.2 When installing a straight Pexgol pipe section between two steel flanges, take into consideration the thermal expansion of the Pexgol pipe.

6. Field welding

- 6.1 The actual length of the pipe can be different than the designed length due to production tolerances and temperature changes.
- 6.2 Field welds should be included in the design in order to compensate for the deviation of the actual length of the pipe during the installation from the designed length.
- 6.3 This is very important in case of pipes and elbows with flared ends. It is a good practice to design some pipe ends with mechanical connections, such as GP Flanged Couplers.
- 6.4 When using only mechanical connectors, design some of them so that the final pipe length can be adjusted on site.

7. Protecting the fittings

- 7.1 When designing Pexgol pipes and fittings, the designer can consider the flexibility of the Pexgol pipes & elbows. In order to reduce the number of fix points, electrofusion and mechanical fittings should be regarded as rigid items.
- 7.2 Special care should be exercised in order to prevent excessive bending moment from being exerted on the mechanical fittings due to forced installation.

8. Fixpoints

- 8.1 In case of fittings that should be protected by fix points (as specified on our Engineering Guide), the fix points must be located before and after each fitting.

For further details see table on page 62 "Other Fittings".

9. Specifying the length of the Pexgol straight sections and elbows as separate items is acceptable after the design has been completed and approved by the designers and by Golan.

9.1 It is a good practice to specify a longer section to allow for measuring inaccuracies other possible errors.



Design Considerations for Pexgol Fittings

- Use only fittings approved by Pexgol and listed in the Engineering Guide.
- Service limitations (as relevant) for each type of fitting are specified in the Engineering Guide. When designing Pexgol pipes and fittings, the designer can consider the flexibility of the Pexgol pipes and elbows. In order to reduce the number of fixpoints, electrofusion and mechanical fittings should be regarded as rigid items.
- Special care should be exercised in order to prevent excessive bending moment from being exerted on the fittings due to forced installation.
- Use special fixpoint clamps before and after the fittings where required (see "Non-restrained fittings").
- Drawings of the fittings are supplied on request.
- For further questions, please consult Golan's application engineer.

PE-Xa Pexgol Elbows

- PE-Xa elbows are available in all pipe classes with diameters up to 710 mm.
- The standard bending radius of the elbows is approximately $R = 3D$ or $R = 1.5D$ for 45° or 90° elbows.
- The working pressures and temperatures are the same as the Pexgol pipe SDR from which the elbow is made.
- Order elbows with plain ends for either flange coupler or electrofusion fittings.
- Elbows with flared ends with or without flanges are available.
- Flared end connectors can be used throughout the entire range of allowable working temperatures and pressures.
- Elbows are supplied with fixture elements in order to maintain the required angle.

PE-Xa Spigot Reducers

- Pexgol spigot reducers of all sizes and all pipe classes are available on request (see page 123 for more details).
- The working pressures and temperatures are the same as for the Pexgol pipe class.
- The Pexgol reducers can be supplied with flared ends, with or without flanges.

Pexgol Spacers and Special Reducers

- Pexgol spacers of all sizes are available on request.

Pexgol Instrument Tees

- Pexgol instrument tees of all sizes are available on request.
- The inlet is made of 316 stainless steel. Other corrosive resistant metals can be specified.

PE-X Lined Steel Fittings

- PE-X lined steel fittings can be used as a part of any Pexgol pipe system. Their working pressures and temperatures are compatible with working pressures and temperatures of the Pexgol pipes.
- The PE-X lined steel fittings are available in nearly any size and shape; see product page for more details.
- The minimum length of each fitting is indicated in the "Fittings Catalogue". This length can be reduced after consulting Golan Plastic Products.
- It is possible to order a non-standard fitting which is a combination of standard fittings, or a standard fitting with longer legs.
- The maximum allowable length for any such fitting is 2200 mm x 2200 mm.
- PE-X lined steel fittings can be used in the following cases:
 - A fitting that is not available as an all-Pexgol fitting is required.
 - The all-Pexgol fitting is too long.
 - A special shape is required.
- All the PE-X lined steel fittings can be connected to the flared ends of the Pexgol pipes without an additional gasket. Additional information can be found on page 62.
- All the PE-X lined steel fittings must be fully supported when installed on pipe bridges.

Pexgol Pipes with Flared Ends

- Pexgol pipes can be ordered in any length up to 11.5 metres (to fit into 40 ft. containers) with one or two flared ends.
- Flared ends connect two Pexgol pipes or a Pexgol pipe to a fitting.
- The sections with flared ends are produced with a tolerance of +/- 10 mm in length.
- No additional gaskets are needed.
- Tightening the flanges of the flared end connectors should be performed as the table in page 73. Simply tighten the bolts evenly around the flange until all bolts are tight.
- The flanges are supplied according to industrial standard ASA 150. Other flanges are available by special order.
- A flared end connection can be used throughout the range of allowable working temperatures and pressures.
- Pexgol elbows with flared ends are also available.

PE100 Electrofusion Fittings

- PE100 couplers can be used up to 45° to 50°C. Regarding working pressures and temperature of PN16 and PN25 couplers, please refer to the recommendations of the approved manufacturers.
- The PE100 electrofusion fittings must be protected in the following cases:
- Above ground installations in extremely low temperatures.
- Underground installations without sand embedding.

Reinforced Electrofusion Couplers Series 1

- Reinforced electrofusion couplers series 1 are used for the same pressure rating as Pexgol pipes SDR 6 up to 70°C.

Reinforced Electrofusion Couplers Series 2

- Reinforced electrofusion couplers series 2 are used for the same pressure rating as Pexgol pipes SDR 6 up to 90°C.

Bolt Connectors

- GP bolt connectors are self-restraint type fittings.
- For full details, see "Fittings Catalogue".
- It is recommended to install brass fittings above the ground. If you must install them anyway, make sure they are protected from corrosion.
- Do not connect brass fittings to steel or galvanized pipes or fittings.

GP Flange Coupler

- Available from 63 mm (with 2" flange) to 710 mm (with 28" flange).
- All couplers comply with ASA 150 flange standard and some of them comply with other international standards.
- GP flange couplers are suitable for the full range of allowable working temperatures and pressures of Pexgol pipes.
- In above ground applications, use special fixpoint clamps before and after the fittings
- In some cases, the ID of the Pexgol pipes might be reduced locally by the GP flange coupler.

Branch Saddles

- Available for Pexgol pipes from 32 mm to 160 mm.
- British Standard Pipe Tapered Threaded (BSPT) threaded outlets.
- Suitable for the full temperature and pressure ranges of Pexgol pipes.
- See "Installation Instruction for Saddles".

Stainless Steel Saddles

- Available for Pexgol pipes from from 110 mm to 630 mm.
- Flanged or threaded outlets (internal thread).

- Maximum outlet diameter: up to half of the pipe's outer diameter.
- The saddles are available with a special rubber coating over the flange and neck to protect from corrosive liquids to which stainless steel is not resistant.
- Temperature up to 85 °C and pressure up to 12 bar.
- In above ground applications, use special fixpoint clamps before and after the fittings.

Victaulic Fittings

- Are approved for use with Pexgol pipe from class 10 up to class 24. Sizes available 63 mm to 355 mm.
- In above ground applications, use special fixpoint clamps before and after the fittings.
- For class higher than 24 please contact Golan application Team.
- Also available Bruno and Aquafast fittings.

Table 61.1: Flared-Ends that require fixpoints

OD (mm)	Class						
	8	10	12	15	19	24	30
32						X	X
40				X	X	X	X
50				X	X	X	X
63				X	X	X	X
75	X	X	X	X	X	X	X
90	X	X	X	X	X	X	X
110	X	X	X	X			
125	X	X	X	X			
140	X	X	X	X			
160	X	X	X	X			
180	X	X	X	X			
200							
225							
250							
280							
315							
355							
400							
450							
500							
560							
630							
710							

Fixpoint is not required Fixpoint is required

Table 62.1: Other Fittings

Fittings	Not Required
Bolt Connectors	X
GP Flange Couplers	
Mechanical double connectors up to class 24	X
Electrofusion Couplers	X
Reinforced Electrofusion Couplers series 1 and 2 up to 70°C	X
Reinforced Electr fusion Couplers series 2 above 70°C	
Victaulic Couplers	

Table 62.2: Gasket use recommendation in Pexgol pipe systems



	Pexgol Flared End	GP Flanged Coupling	PE-X Lined Steel Fitting	Teflon Lined Steel Fitting	PE-Xc Fitting	Steel flange/Valve
Pexgol flared end	NO	NO	YES	YES	YES	NO
GP Flanged Coupling	NO	NO	NO	NO	NO	NO
PE-X Lined Steel Fitting	YES	NO	YES	YES	YES	YES
Teflon Lined Steel Fitting	YES	NO	YES	YES	YES	YES
PE-Xc Fitting	YES	NO	YES	YES	YES	YES
Steel Flange/ Valve	NO	NO	YES	YES	YES	YES

2023

Design Considerations

Abrasion Resistance

Transporting solid materials by fluids (in the form of a slurry) is common in industry, mining, and in many piping systems. In most cases, the flow is kept turbulent to avoid sedimentation.

Abrasion is the result of the inner surface of the pipe wall being removed or degraded by flowing media in the pipe. The rate of abrasion for various slurries is determined by many factors such as:

- Flow rate
- Density of the particles
- Size distribution of the particles
- Hardness and angularity of the particles
- Temperature viscosity of the liquid
- Incorrect installation

Abrasion resistance is one of the most important advantages of Pexgol pipes. Pexgol's excellent abrasion resistance is result of the unique structure of crosslinked polyethylene, making the pipe material especially tough and resilient, and generally able to resist abrasion better than metal pipes.

The ability of the pipe material to absorb the kinetic energy of the hard particles inside the slurry and its resistance to deformation make Pexgol pipes extra-ordinary abrasion resistant conduits.

Unavoidable scratches in Pexgol pipes cause no damage. Results of tests performed on pipes after being subjected to scratches as deep as 20% of the pipe wall show that no damage is caused to the pipe during intensive pressure tests. The crosslinked molecular structure accounts for the insensitivity of Pexgol pipes to scratches as well as their resistance to slow-crack growth.

The restraining action of the adjacent molecular chains of the crosslinked network absorb the energy of the "tearing" forces.

Pexgol pipes abrasion resistance was tested and approved in laboratory tests as well as in on-site conditions.

In South African gold mines, Pexgol pipes were installed in backfill lines, working at a very high line velocity, transferring highly abrasive material for many years without failure. In Israel's Dead Sea Works, 450 mm Pexgol pipes have been installed since 1985, instead of steel pipes, which had to be replaced every year. These pipes are connected to dredgers which "harvest" the salt particles.

Non-crosslinked PE pipes, which were installed in these lines, failed after a few months.

Pexgol pipes have been at work since 1985, and it has not yet been necessary to replace them.

Technical test reports concerning abrasion resistance of Pexgol pipes are available on request.

Abrasion Allowance

Pexgol pipes have an "abrasion allowance" of 20% of the nominal wall thickness of the pipe. This means that the pipe can withstand the design working pressure until the remaining wall thickness of the pipe is reduced to 80% of the nominal value. The real lifetime of the pipe depends on the actual abrasion rate in the line.

The 80% rule applies for all working pressures and all temperatures in all classes.

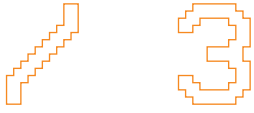

Installation Instructions

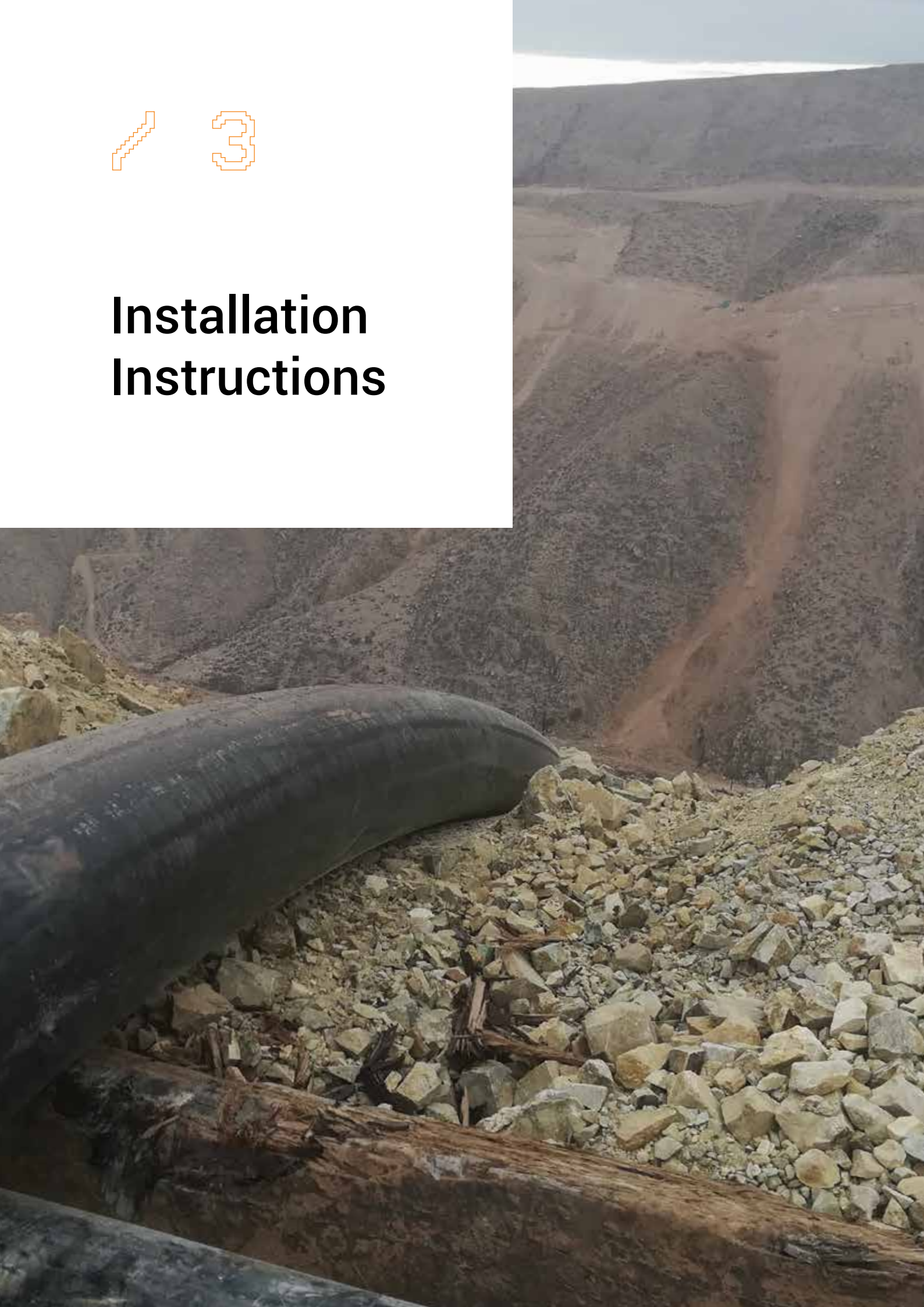



Index

Performing Pressure Tests in Pexgol
Water Supply Lines & Dewatering

Instructions for Welding EF Fittings

Electrofusion Welding

Saddle Welding

Installation for Branch Mechanical
Saddles

Connecting Pexgol Pipes with
Flared Ends

Repair Instructions for Pexgol Pipes

Guidelines for Underground
Installations

Backfilling of the Trench

Above-Ground Installation
Guidelines

Pexgol Horizontally Supported
Pipeline

Performing Pressure Tests in Pexgol Water Supply Lines and Dewatering

Test purpose: final check to make sure there are no leakages in the fittings.

Considerations:

1. It is recommended to fill up the pipeline with water at the maximum working pressure on the day before the test.
2. On the day of the test, inspect the pipeline visually, especially around the fittings.
3. Temporarily cover metal fittings (flange couplers, branch-off saddles) to prevent excessive heat build-up due to exposure to sunlight.
4. Take into consideration changes in the pipeline topography (which could create higher local pressure due to a water column); reduce the test pressure accordingly.

Note: In case of underground system, make sure the pipes are already covered.

Pressure Testing:

1. Bring the pressure to 25% above the line design pressure and then close the feeding line.
2. As the pipe is flexible and tends to expand its diameter under pressure, the line pressure is expected to decrease.
3. Increase the line pressure again, up to the test pressure and wait 30 minutes for pressure to stabilize.
4. With each cycle of pressure reduction and increase, the pressure is expected to decrease less.

After 3-4 cycles, open the valve and close it immediately, rapidly lowering the pressure to approx. 75% of the test pressure by letting water out of the line.

1. After closing the valve, the pressure is expected to increase as a result of the tendency of the pipe to decrease its volume.
2. If the pressure decreases instead of increasing, investigate the reason for pressure loss, for example, leakages at the fittings.

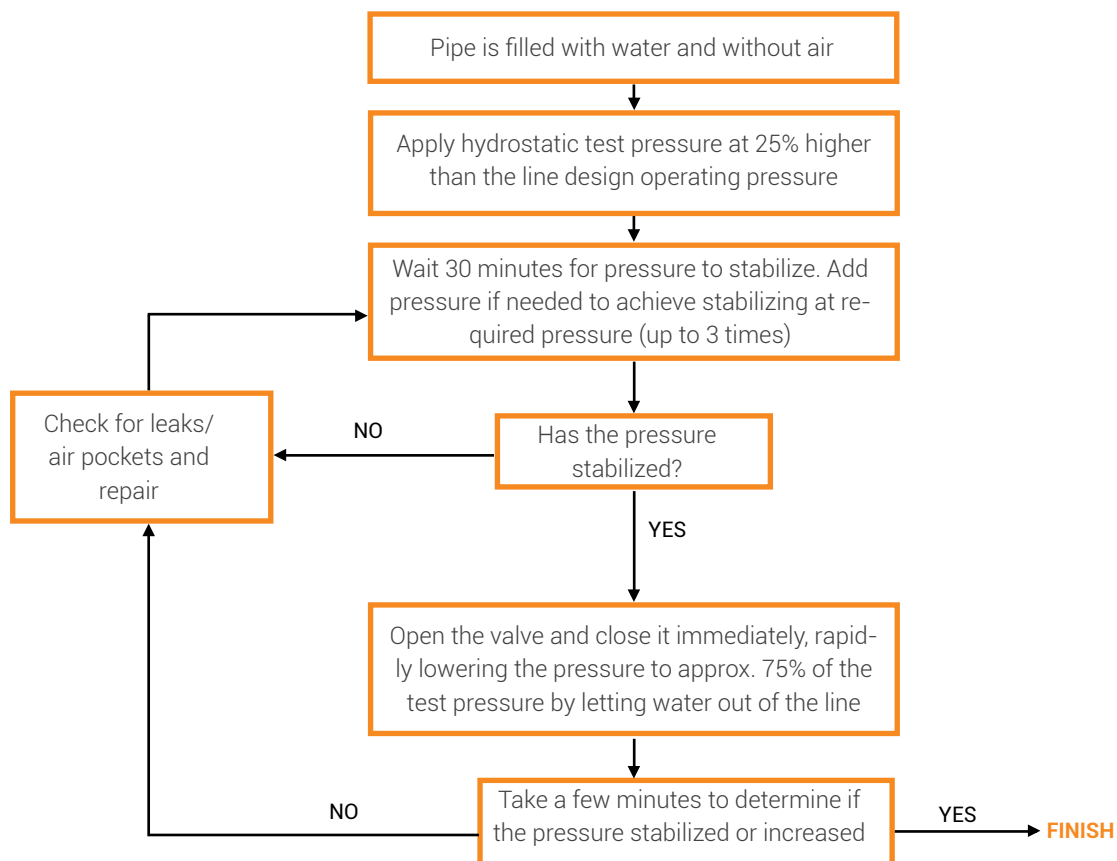

Instructions for Welding Electrofusion Fittings

Electrofusion fittings can be used to connect Pexgol cross-linked polyethylene pipes.

The pipes and fitting are connected by means of fusion welding creating a leak-proof seal. A sealing ring is not needed.

During the electrofusion process a current is transported through a heating wire.

- The surrounding material around the wire is melted and welds the pipe to the fitting.
- Electrofusion system is one of Pexgol's connector systems, providing all connection technologies for Pexgol pipes.
- Electrofusion fittings are the main means of connection in municipal water and industrial distribution systems.
- Fittings are tested and have a lifetime of 50 years, according to the European standards a working pressures of 16 atm in water networks.
- Lightweight and small volume welding connectors.
- Economical use especially for big diameters in water transportation.
- Connectors are offered in diameters ranging from 20 mm to 630 mm as well as in a wide variety: couplers, elbows, end plugs, tees, saddles, tapping saddles (for connecting new outlets to "live line").

The entire electrofusion process is executed and fully monitored by the computerised control box ensuring safe, reliable connections.

Installation Instructions for Electrofusion Fittings

Installation performed only by trained workers who have received a valid certificate showing that they have been trained by a person authorized by Pexgol.

Type of Electrofusion Fittings

Use only electrofusion fittings approved for fusion with Pexgol cross-linked polyethylene pipes.

Wall thickness defined as follows:

- 25 – 75 mm pipes, minimum S.D.R. 11
- 90 – 355 mm pipes, minimum S.D.R. 16.2

Pressures

PN 16 electrofusion fittings are suitable for working together with Pexgol pipes which are rated up to pressures of P.N. 15 in water or 10 bars in gas (only PE spigot connectors are produced in two levels, P.N. 10 and P.N. 16).

Note: Electrofusion couplers PN10 should not be used with Pexgol pipes of all classes



Rounding the Pipe

For a quality fusion and for easy insertion, rounding the pipe is compulsory. This is achieved by using rounding tools which are placed on the pipe end. The tools maintain a rounded pipe during the welding process.

Support of the Fitting during the Welding Process

When welding pipes in diameters 90 mm and higher, the pipe should be inserted into the fitting by means of spanners (come-alongs) which allow controlled insertion and ensure the coupler does not move during the welding process.

Cooling Time

Please note the cooling time that appears on a sticker on each fitting.

Do not disassemble spanners and rounding devices until the cooling time has elapsed.

When the fusion process is completed, note the hour and add the cooling time. The result is the disassemble time. Mark this time on the fitting and do not disassemble it earlier than this time!

Pexgol electrofusion fittings are allowed for use up to 50°C according to the pressure rating at Plasson catalog: In case of higher pressures please consult the Pexgol Field Service.

Working Instructions

1. Preparing the fittings for welding: Preparation and welding can be conducted at ambient temperature. If the weather is windy (with dust) or rain or other sources of humidity, the welding area should be protected by a cover or welding should be halted until the weather conditions are suitable.
2. Preparation (cleaning and scrubbing) must be done close to the welding time. Do not prepare pipes and fittings for welding if you plan to weld at a later stage.
3. Scraping and peeling of the pipe: universal or hand scraper must be in perfect working condition with a sharp blade. The blade in the universal scraper should be replaced when no longer sharp. The blade of the hand scraper should be sharpened from time to time using a fine iron file.

The thickness of the scraped layer should be as follows:

- Diameter: 20 - 25 mm, 0.15 - 0.20 mm
- Diameter: 32 - 75 mm, 0.15 - 0.25 mm
- Diameter: 90 - 355 mm, 0.20 - 0.30 mm



Electrofusion Welding

A. Marking the pipe for cutting

The pipe must be free of dirt and dust:

1. Use a plastic marking tape long enough to go around the pipe circumference.
2. Mark the welding location around the pipe with a marker.



B. Cutting the pipe

1. Use a cutting tool for plastic pipes up to diameter 6". From diameter 8" and higher use a Jigsaw cutter, with a suitable plastic saw



C. Rounding of the pipe and scraping the oxidised layer

1. Round the pipe prior to scraping it.
2. Place the rounding device on the pipe so that the distance from the pipe to the rounder is equal to the depth insertion of the pipe into the fitting plus 4 centimetres.

Note: To ensure perfect, symmetric roundness of the pipe, make sure that the rounding device is placed in such a way that the screws will be on the flattened sides of the pipe (on the narrow axis of the oval) and fasten them until perfect roundness of the pipe is reached.

3. Use the universal rotational scraper according to the instructions.

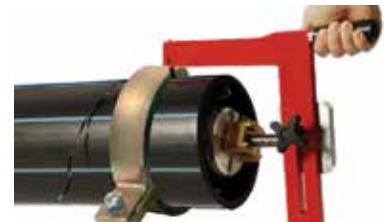

D. Pipe Preparation

1. The pipe must be marked to prepare insertion of the fitting.
2. Move the rounding device until the marking of the full insertion.
3. It is absolutely necessary to clean the entire welding surface. This is performed with a special cleaning solution of 95% ethanol (or equivalent) and new clean paper wipers to ensure that no fibres are left on the surface.



E. Installing the Fitting onto the Pipe

1. Remove the fitting from its original packaging, only when you are ready to start the welding process. Clean the inner side of the fitting with the special cleaning solution. Clean the pipe surface again.
2. Install the fitting onto the prepared pipe and make sure that the pipe is fully inserted into the fitting up to the end. The fitting should fit easily into the pipe.



F. Preparation of the Opposite Pipe End for Insertion

1. Clean, mark and place the rounding device as described.
2. Pull the pipe into the fitting by means of 2 spanners from each side until the rounder and the coupler meet.
3. Make sure to insert the pipe straight and precisely along the axis of the fitting by guiding both spanners. Make sure that there are no "angles" between the pipe's axis and the fitting's axis.



G. Welding

Please follow carefully installation instructions for the electrofusion control box:

1. Connect the terminals from the control box to the fitting. Make sure to connect "black to black" and "red to red", and make sure that the electric cable is loose, not pulled tight.
2. Operate the control box and start the welding process.



H. Cooling time

At the end of the fusion carefully remove the black and red terminals from the fitting.

1. The correct cooling time is shown on the barcode label on each fitting. Mark on the coupler the exact hour when the coupler can be removed (adding the correct cooling time to the exact hour when the fusion was completed).
2. Dismantle the clamps and rounding equipment only at the end of the cooling time.

Note: Since pressure testing requires lower temperatures of the joint, we recommend waiting twice the cooling time after fusion before pressurising the pipe and waiting 3 times the cooling time after fusion before beginning pressure testing.

Saddle Welding

A. Pipe must be marked

The pipe must be free of dirt and dust.

1. Place the lower part of the saddle on the place intended for fusion, mark the location of the outlet by marking a line all around the pipe. Use the lower part of the saddle for marking in order to avoid dirtying the upper part prior to welding.
2. Mark 3 lines on each side of the line at a distance of 30 mm from each other.
3. Remove the lower part and scrape the marked area with a manual scraper until all lines are scraped (except for the center line).

Note: The manual scraper should be very sharp. Sharpen it by rotating the knife from time to time (4 positions) and by sharpening it with a fine iron file. Use a manual scraper and scrape using two hands to achieve best results.



B. Pipe preparation and mounting of the saddle

1. Clean the pipe with a special cleaning solution for PE cleaning (ethanol) as any other fluid may damage the joint. To apply the solution, use clean wipes.
2. Clean the inner side of the upper saddle and install it to the pipe.
3. Close the saddle screws so that the upper and lower parts meet.
4. Fasten the screws.

Note: The hole should be drilled only after the welding is completed.



C. Welding

Please follow carefully installation instructions of the welding device.

1. Connect the terminals from the generator to the saddle "red to red", "black to black".
2. Operate the generator and start welding process.



D. Cooling time and drilling of hole

Cooling time:

1. At the end of the fusion carefully remove the black and red terminals from the fitting.
2. Mark on the coupler the exact hour when the coupler can be removed (adding the correct cooling time to the exact hour when the fusion was completed).
3. Dismantle the clamps and rerounding equipment only at the end of the cooling time. After cooling, drill the outlet hole using a hole saw tool.

Installation of Mechanical Branch Saddles

Note: The following data for installing Golan brass saddles, electrofusion saddles and Krausz stainless steel saddles to Pexgol pipes. Install all saddles onto the pipe prior to drilling the outlet hole.

Table 72.1: Dimensions of drills for outlet hole in brass saddles

Dimensions of drills for outlet hole in brass saddles		
Brass saddles dimensions	Thread	Diameter and drill type
32x3/4"	Female	13 mm drill
32x1/2"	Male	13 mm drill
40x3/4"	Female	13 mm drill
40x1/2"	Male	13 mm drill
50x3/4"	Male	22 mm hole saw tooth
63x3/4"	Male	19 mm hole saw tooth
63x1"	Male	24 mm hole saw tooth
63x2"	Female	45 mm hole saw tooth
75x1 1/2"	Male	35 mm hole saw tooth
75x2"	Female	45 mm hole saw tooth
90x1 1/2"	Male	33 mm hole saw tooth
90x2"	Female	45 mm hole saw tooth
110x2"	Female	45 mm hole saw tooth
160x2"	Female	45 mm hole saw tooth

Note:

- Saddles up to 63 mm – 11 mm wrench
- Saddles 75 mm and 90 mm – 14 mm wrench
- Tighten the saddles until the two halves meet.

Table 72.2: Dimensions of drills for outlet hole in stainless steel saddles

Dimensions of drills for outlet hole in stainless steel saddles			
Outlet type	Outlet size	Drill type	Drill diameter (mm)
Female outlet thread	1 1/2"	Hole saw tooth	40
Female outlet thread	2"	Hole saw tooth	51
Flanged outlet	2"	Hole saw tooth	40
Flanged outlet	3"	Hole saw tooth	70
Flanged outlet	4"	Hole saw tooth	92
Flanged outlet	6"	Hole saw tooth	140

Install electrofusion saddles of all manufacturers (Plasson, Friatec, GF/Wavin) and Plasson mechanical saddles according to the manufacturer's instructions.

Connecting Pexgol Pipes with Flared Ends

The flared-end connection is suitable for both hot and cold media. Special fixpoint clamps should be used before and after the flared ends (see Table 61.1). Standard flanges are carbon steel ST-37 with cold galvanized coating according to ASTM B633-15 Type 2 class 3. For other flange material contact Golan application team

In case of subzero temperatures, special restraining techniques should be employed to prevent pulling out of the flared end from the flanges.

No gasket is needed when connecting two Pexgol pipes with flared ends and flanges (see Table 61.3).

If torque wrenches are applied, use the recommended

value from the following table. Tighten the bolts evenly in criss cross manner using 75% of the recommended torque values and then tighten to the final value.

Table 73.1: Tightening torque values for Pexgol flared ends

Pexgol Pipe diameter (mm)	Flange size	Bolt size**	Bolt length (mm)**	No. of bolts	Torque N x m	Torque lb x ft
63	2"	5/8"	50	4	98	72
75	2 ½"	5/8"	50	4	98	72
90	3"	5/8"	50	4	98	72
110	4"	5/8"	50	8	98	72
125	4"	5/8"	50	8	98	72
140	6"	3/4"	60	8	163	120
160	6"	3/4"	60	8	163	120
180	6"	3/4"	60	8	163	120
200	8"	3/4"	60	8	163	120
225	8"	3/4"	60	8	163	120
250	10"	7/8"	70	12	260	192
280	10"	7/8"	70	12	260	192
315	12"	7/8"	70	12	260	192
355	14"	1"	70	12	399	294
400	16"	1"	75	16	399	294
450	18"	1-1/8"	75	16	578	426
500	20"	1-1/8"	100	20	578	426

Repair Instructions for Pexgol Pipes

1. Small hole (up to 5 cm diameter)

- Uncover the pipe, 2 metres along the pipe and 0.5 metre below the pipe.
- Carefully clean the soil from the pipe and make sure no scratches extend beyond the repair area.
- Use a repair fitting, supplied by Golan or use a branch-off saddle.
- In case of vertical installation (dewatering line), the fitting must be protected by a fixpoint bridge.



Repair Stainless Steel Mechanical Fitting



Repair PN16 EF Fitting

2. Large hole requiring (replacing a pipe section)

- Uncover the pipe, 3 metres along the pipe and 0.5 metres below the pipe.
- Cut out the section of the pipe with the hole and replace with a new section.
- In most cases, the maximum length of the section to be replaced does not exceed 1 metre in length.
- The new section will be connected by:
 - Two electrofusion repair couplers
 - Four Golan flange couplers
- For specification for stainless steel, see page 52.

Notes:

- Only technicians trained by Golan's field service personnel are authorised to perform the repair.
- If necessary, can stop water flow using common squeeze-off techniques.
- In case of a vertical installation (dewatering line), the pipe must be secured by a fixpoint bridge prior or cutting the pipe.
- Follow the instructions according to the size of the hole in the pipe.

Guidelines for Underground Installations

Pexgol recommends a maximum installation depth of 7 metres underground. For deeper installations up to 20 metres, a sand bed of 15-20 cm is recommended.

In other cases, we recommend following the guidelines in the PPI chapters 6-7.

Backfilling of the Trench

The excellent scratch resistance of the Pexgol pipes enables laying the pipes in trenches with no sand bedding; if sand bedding is required by the pipe designer, fill the trench with sand 10 cm above the pipe.

Backfilling the trench using the earth originally removed from the trench is allowed; if corrosive soil is used to cover Pexgol pipes that are connected with metal fittings, cover the fittings with sand, not with the corrosive soil.

No compacting is required for any class of Pexgol pipes regardless of the depth of the trench.

Installation below a road or a pavement can be done without any protective sleeves. In this case, controlled compacting of the soil/ground, according to the designer's instructions, should be applied when covering the pipe to prevent the ground sinking.

It is recommended to insulate hot water underground Pexgol pipes to reduce energy losses.

Table 75.1: Minimal trench width - for single pipe

Outside pipe diameter (mm)	Minimum trench width (mm)
90	250
110	250
125	265
140	280
160	300
180	350
200	400
225	400
280	450
315	550
355	650
450	750
500	850
630	1000



Above-Ground Installation Guidelines

Above-ground installation of Pexgol pipes is advantageous:

- Slurry lines which are frequently relocated.
- Installation through marshes or areas with difficult access.
- Quick installation of temporary pipelines.

Pexgol pipes withstand exposure to sunlight for pipe lifetime.

The coefficient of expansion of Pexgol pipes is high compared to steel pipes, but the forces generated by thermal stresses are much lower. The reason is the low modulus of elasticity and the fact that the Pexgol pipes feature stress relaxation.

Pexgol pipes installed above ground might increase in length as a result of temperature increases and tend to undergo "snaking". Longitudinal elongation and contraction of the pipe is not uniform due to the coefficient of friction between the pipe and the ground varies. However, the toughness and the exceptional abrasion resistance of Pexgol pipes enable the pipes to move across the soil without affecting strength or service life.

Above ground installation instructions for Pexgol pipes laid on the ground

When the design temperature is lower than the installation temperature. The pipe tends to contract.

The contraction creates axial stresses in the pipes which tend to pullout the pipes from the fittings.

Installing Pexgol pipes above the ground with a calculated slack rather than in a straight line, is a way to reduce thermal stresses.

This procedure reduces the tendency of the pipe to pull out of its fittings.

The slack (calculated according to the Pexgol coefficient of thermal contraction) is 0.2% or 2 mm for every metre per 10°C.

The actual value depends on the temperature difference between the installation temperature and the lowest temperature.

The slack can be maintained by pushing the mid span of the pipe slightly sidewise during the installation.

Axially unrestrained fittings should be secured and protected from pull out, (see page 56).

Maintaining Pexgol pipeline in a straight line, on the ground or on pipe racks

If a straight pipeline is required, guiding the pipeline at intervals is a good method of limiting and controlling thermal expansion and contraction of the pipeline.

The smaller the distance between the guides, the smaller the theoretic increase in pipe length. As a result, lateral deflections decrease and the pipeline remains straight.



Calculation of Forces at Fixpoints (due to thermal expansion/contraction)

The axial forces transferred from the Pexgol pipe to the construction (through the fixpoint) are calculated by adding the values of the thermal stresses for the temperature range between Ti (Initial Temperature) until Tf (Final Temperature), and then multiplying that value by the cross section of the pipe.

$$F_{\text{thermal}} = \sigma_{\text{thermal}} \times \text{SRF} \times A$$

Where:

σ_{thermal} - thermal stress

SRF - Stress Relaxation Factor for Pexgol piping = 0.7

A - Cross section of the pipe =

$$3.14 \times (D-t) \times t \text{ [mm]}$$

D - Outer Diameter (mm)

t - Wall thickness (mm)

Table 77.1: Initial short term thermal stresses vs design temperature

Design Temperature		Thermal stress [MPa]
Ti [C°]	Tf [C°]	
100	110	0.25
90	100	0.26
80	90	0.28
70	80	0.29
60	70	0.31
50	60	0.36
40	50	0.41
30	40	0.53
20	30	0.65
10	20	0.66
0	10	0.88
-10	0	1.01
-20	-10	1.30
-30	-20	1.61
-40	-30	2.72
-50	-40	1.11

For example, if we want to calculate the axial forces a 280 mm class 15 (SDR 11) Pexgol pipe exercises on the fixpoints when **heated** from 20°C to 60°C, then we look up our relevant range and sum the Thermal stress' values:

$$(0.65+0.53+0.41+0.36) = 1.95 \text{ MPa}$$

Wall thickness of such pipe is 25.4 mm so the area of the cross section of the pipe equals to:

$$3.14 \times 254.6 \times 25.4 = 20,306 \text{ mm}^2$$

Design Temperature		Thermal stress [MPa]
Ti [C°]	Tf [C°]	
50	60	0.36
40	50	0.41
30	40	0.53
20	30	0.65

The axial forces on the fixpoints are:

$$F_{\text{thermal (heating)}} = 1.95 \times 0.7 \times 20,306 = 27,717.7 \text{ N} = 2.77 \text{ Tons}$$

These Forces (due to thermal expansion/contraction) need to be taken as positive in case of heating (expansion) or alternatively as negative in case of cooling (contraction).

If the same pipe was to be **cooled** from 30°C to 10°C then we would add together the Thermal stress' values that are relevant to our case:

$$F_{\text{thermal (cooling)}} = 1.31 \times 0.7 \times 20,306 \times (-1) = -18,620.6 \text{ N} = -1.86 \text{ Tons}$$

Design Temperature		Thermal stress [MPa]
Ti [C°]	Tf [C°]	
20	30	0.65
10	20	0.66

$$(0.65+0.66) = 1.31 \text{ MPa}$$

* The (-1) expresses the direction of the force that the pipe exercises on the fixpoint, and will correlate to the Bourdon Effect (influence of pressure) as follows.

Calculation of additional Forces due to influence of internal Pressure:

$$F_{\text{pressure}} = (0.5 - \nu) \times P \times (D/2t) \times A$$

Where:

ν - Poisson Ratio. The ratio at final temperature (Design Temperature).

Design Temperature	-50°C to 70°C	Above 70°C
Poisson Ratio	0.4	0.5 (no effects from pressure)

P – Pressure (MPa)

A – Cross section of the pipe (mm²)

D - Outer Diameter (mm)

t - Wall thickness (mm)

$$F_{\text{total}} = F_{\text{thermal}} + F_{\text{pressure}} = \sigma_{\text{thermal}} \times \text{SRF} \times A + (0.5 - \nu) \times P \times (D/2t) \times A$$

Now we can apply the effects of pressure to our previous calculations for 280 mm class 15 (SDR 11).

We will assume a pressure of 6 bar in the first case (heating) and 8 bar for the second (cooling):

A. Forces from thermal expansion at heating from 20°C to 60°C are 2.77 tons. We will add to this the forces that are transferred as consequence from pressure.
 $F_{\text{pressure}} = (0.5 - \nu) \times P \times (D/2t) \times A = (0.5 - 0.4) \times 0.6 \times (280 / (2 \times 25.4)) \times 20306 = 6,769 \text{ N} = 0.68 \text{ Ton}$
 $F_{\text{total}} = 2.77 + 0.68 = 3.45 \text{ Ton}$

B. Forces from thermal contraction at cooling from 30°C to 10°C are -1.86 tons. We will add to this the forces that are transferred as consequence from pressure.
 $F_{\text{pressure}} = (0.5 - \nu) \times P \times (D/2t) \times A = (0.5 - 0.4) \times 0.8 \times (280 / (2 \times 25.4)) \times 20306 = 9,025 \text{ N} = 0.9 \text{ Ton}$
 $F_{\text{total}} = -1.86 + 0.9 = -0.96 \text{ Ton}$

In the cooling scenario we can appreciate how the forces transferred to the fixpoint from the effect of pressure are in the opposite direction of those that came from thermal contraction, therefore easing the total force instead of adding to it (hence the importance of the negative sign expressing direction).

Software

Information relevant to the use of Force Calculation Software

Standard software stress analysis (such as CAESAR) works under the assumption that the pipe is operating within its limits of elasticity. This does not apply to plastic pipes.

Therefore, attempting to calculate the forces which the pipe transfers to the fixpoint clamps whilst using this sort of steel orientated software (that fail to consider the plastic behavior of the pipe), often returns values significantly higher than those obtained through the method described in the PPI - PE-X Manual (Plastic Pipe Institute).

Other programs, for example Start-Prof, can perform analysis according to DVS 2205/DVS 2210 codes.

The short-term Elastic Modulus and the Instantaneous Thermal Expansion Coefficient can both be found at PPI - PE-X Manual (Plastic Pipe Institute).

Poisson Ratio should be taken as follows:

Design Temperature	-50°C to 70°C	Above 70°C
Poisson Ratio	0.4	0.5

Mean Thermal Expansion Coefficient as required in Start-Prof Material Database is detailed at Table (2.2):

T [C°]	Mean coefficient α [1/°C]
100°C	2.37E-04
90°C	2.14E-04
80°C	1.93E-04
70°C	1.75E-04
60°C	1.58E-04
50°C	1.46E-04
40°C	1.36E-04
30°C	1.24E-04
20°C	1.16E-04
10°C	1.04E-04
0°C	9.8E-05
-10°C	8.8E-05
-20°C	7.97E-05
-30°C	7.15E-05
-40°C	6.36E-05
-50°C	5.5E-05

Maximum allowable stress as function of pipe temperature:

These values are based on DIN 16893 and the accumulated experience of Pexgol pipes in Infrastructure and Industry applications.

The maximum allowable stresses in the table were calculated with a safety factor (SF) of 1.25 (which DIN 16893 designates for water).

A different SF may be considered in case of working with chemicals and corrosive agents (see chemical resistance tables in our Engineering Guide).

Table 79.1: Changes of Design Stress Values σ with Temperature

Temperature (°C)	σ (kg/cm ²)
10°C	85
20°C	76
30°C	66.5
40°C	59
50°C	52.5
60°C	48
70°C	42.5
80°C	37.5
90°C	33.5
95°C	32
100°C	27.5
105°C	22.5
110°C	18.75

Note: Some software's will apply specific safety factors as default. To avoid duplications, when calculating maximum allowable stress, make sure the SF is not already applied. Be sure to input an equivalent to our Stress Relaxation Factor of 0.7 to your simulation. This can be entered as Laying Conditions Factor or other.

Pexgol Horizontally Supported Pipeline

The recommended distance between two adjacent supports for Pexgol pipes can be determine based on the following graph:

(The graph was prepared based on formulas found in PPI, Chapter 8: Above Ground Applications for PE pipes)

Table 80.1: Maximum supports distance

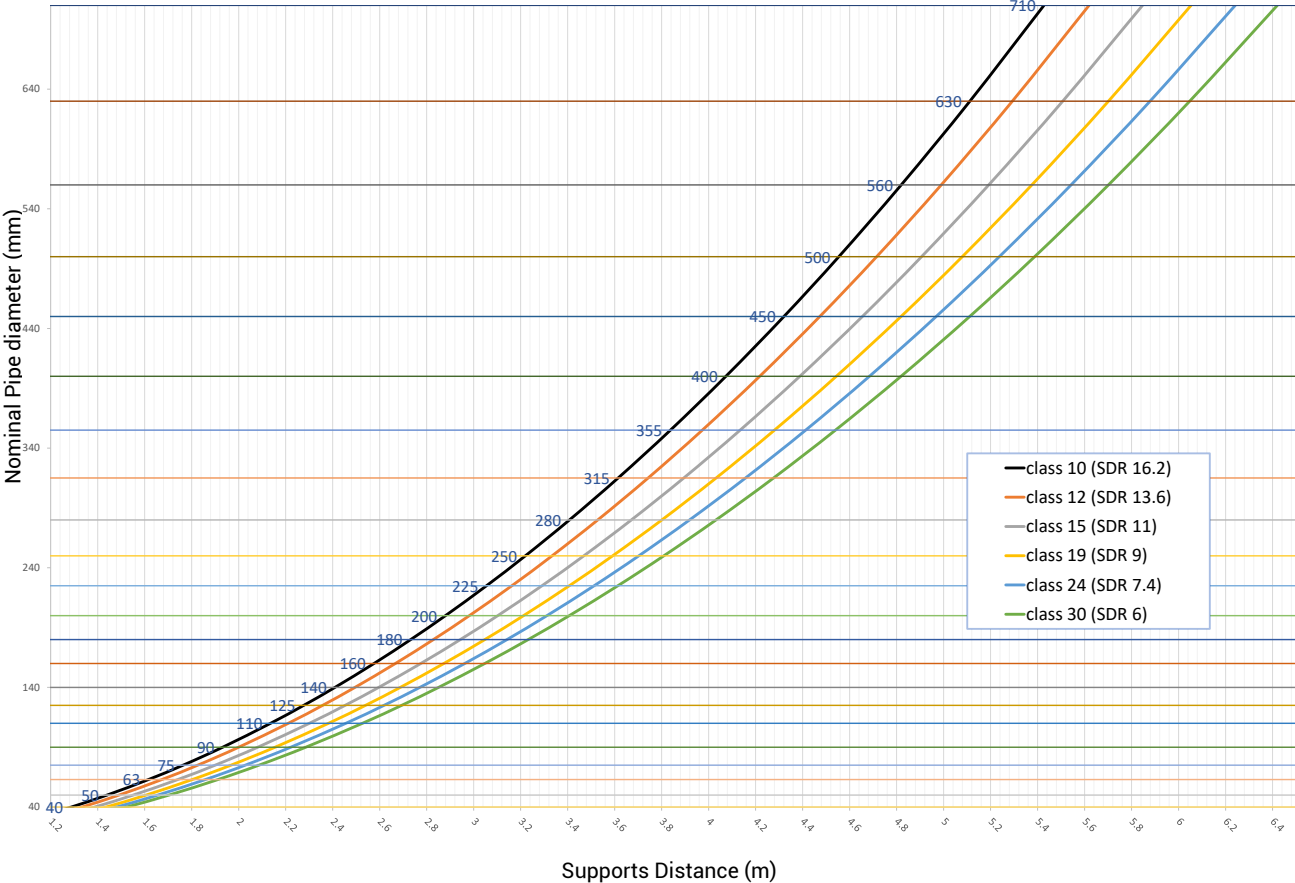

In the graph we calculated the Span length L for a Pexgol pipe transporting water at 20°C, with a permissible Deflection value of 0.5" (in) / 12.5 (mm).

Notes:

In case of different design temperatures, use the correction values in the table.

The Span length was calculated for water. In case of other fluid densities, the "Water" span length should be multiply by $(1/\rho)^{0.25}$ where ρ is the density of the fluid.

Other values of Permissible Deflection can be chosen by the designer

The values shown in Table 80.1 must be multiplied by the following Temperature correction factors in Table 81.2.

Table 81.2: Correction factors

Correction factor	Design temperature °C
1.03	0 °
1.02	10 °
1.00	20 °
0.98	30 °
0.94	40 °
0.93	50 °
0.91	60 °
0.87	70 °
0.83	80 °
0.79	90 °
0.75	100 °
0.71	110 °

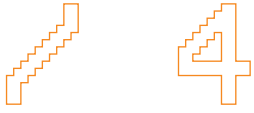

Pexgol Solutions





Index

Industry

Dewatering Lines
Borehole Rising Mains
Industrial Installation example
Industrial Applications

Infrastructure

Infrastructure Applications
Pexgol Cold Water Supply Installation Guide
Pexgol Lines for Very Low Ambient Temperatures
Pexgol Fire Extinguisher Lines
Natural Gas Pipes
Air Supply Pressure Lines
Pexgol Pre-Insulated Pipes

Residential

Pexgol Solutions for Hot and Cold Water
Hot Water Risers

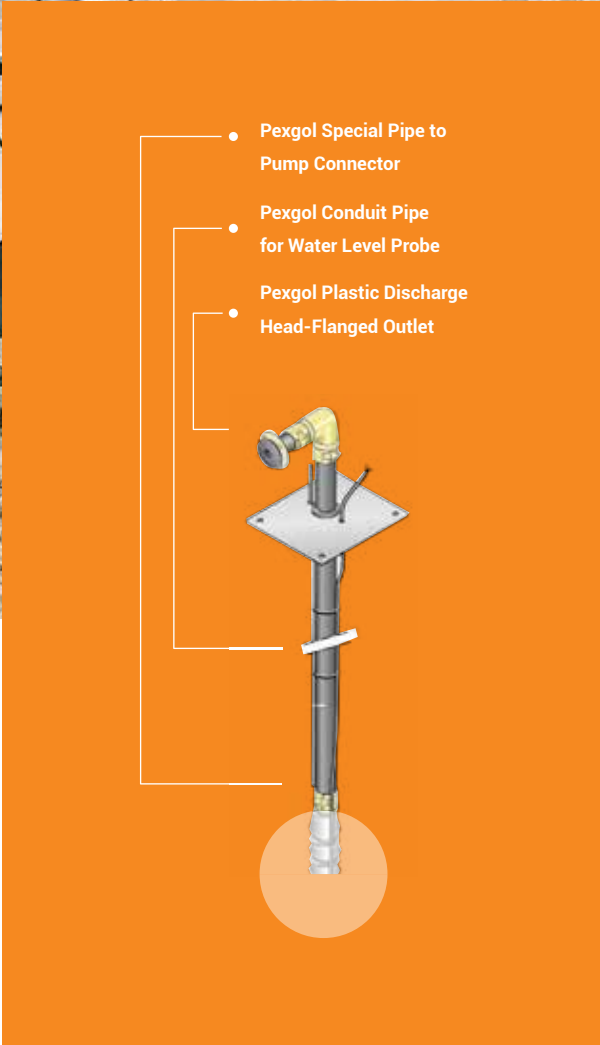
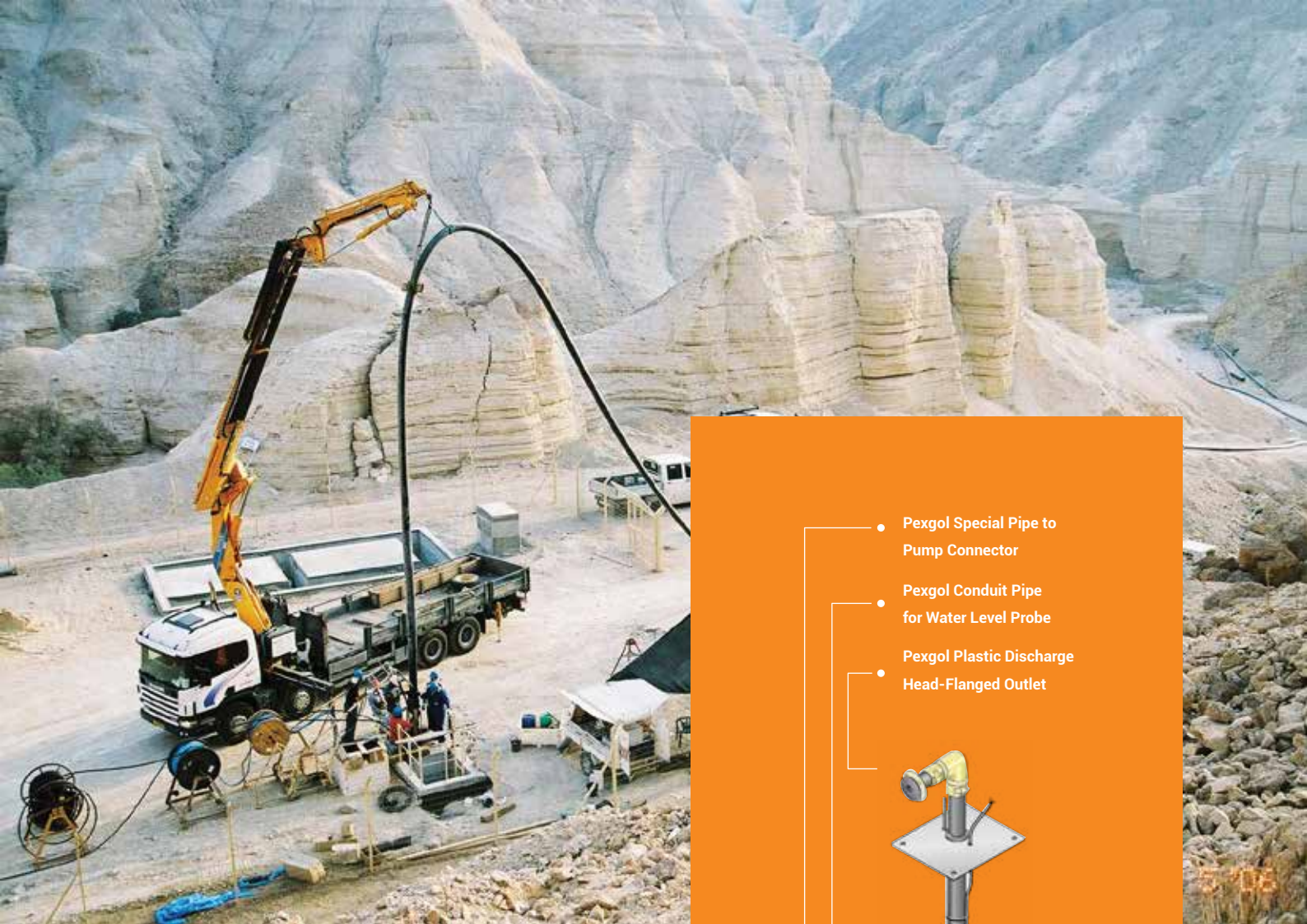

2023

Industry

Dewatering Lines

Pexgol pipes are a good solution for dewatering lines. They can be supplied in any required pressure class in long continuous lengths and can be dragged on the ground to the final location. Pexgol pipes are easily installed as they do not require anchoring along the line, since the pump is not suspended on the pipe and the weight of the pump and water column are not carried by the pipe. The end fittings should be protected by a pullout prevention technique such as fixpoints. Fittings along the line should be protected by a floating fixpoint device such as our fixpoint bridge (see pages 134 and 160). For dewatering design considerations see "Inclined and Dewatering pipes" on pages 54 to 57.

Borehole Rising Mains

Pexgol pipes are used for pumping water in boreholes up to 300 metres dynamic water level. The pipes are supplied with special borehole fittings.

Industrial Installation example

1. Flared end connector with a loose flange
2. 90°-1.5 D elbow with two flared ends and two loose flanges
3. Special Pex-lined fitting (equal Tee with a reducer)
4. Pipe spool with one flared end & a loose flange
5. Flanged coupling (used for "field welding" adjustment)
6. 90° 3 D elbow with two flared ends and two loose flanges
7. Pipe spool with two flared ends & two loose flanges
8. Stainless steel branch-off saddle with 2" flanged outlet
9. Standard Pex-lined lateral Tee
10. Long spool with a natural bend & a flared end connector with a loose flange
11. Standard Pex-lined 1.5D elbow
12. Standard Pex-lined concentric reducer
13. Pipe spool with one flared end & a loose flange
14. Electrofusion coupling
15. 90° 3 D elbow with two flared ends and two loose flanges

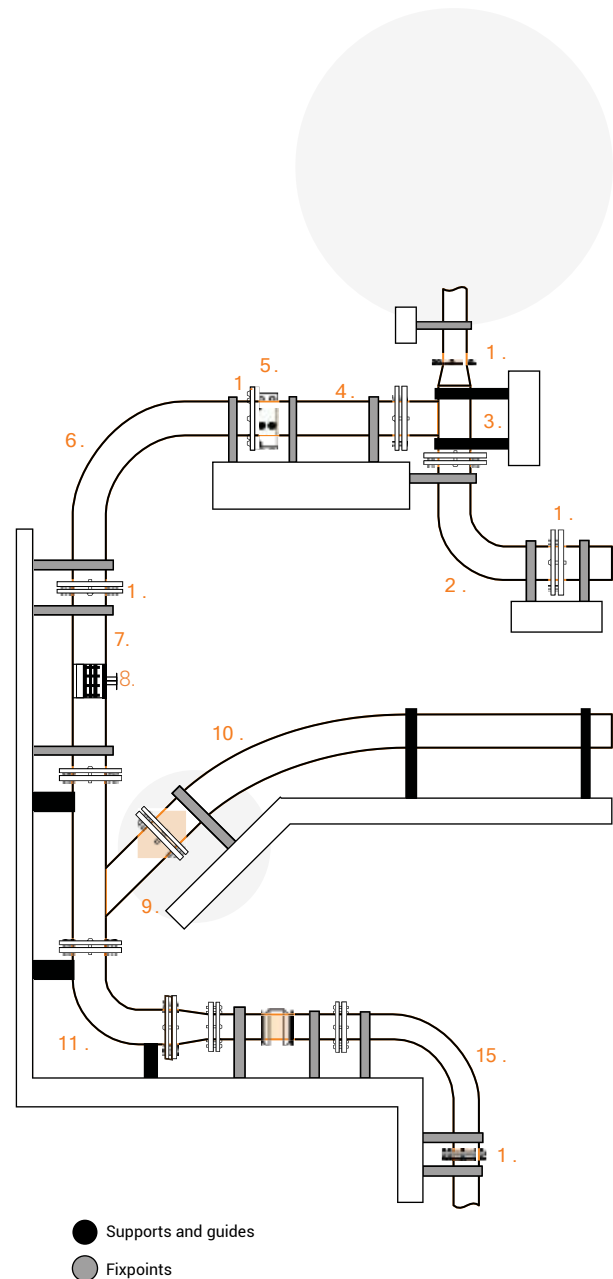

Industrial Applications

Pexgol pipes with their excellent resistance to temperature extremes, chemicals and abrasion are ideal conduits for a wide range of industrial applications (see Chemical Resistance).

Pexgol pipes offer a successful, cost-effective solution where conventional pipes would be unsatisfactory for conveying slurries due to their poor abrasion resistance or because of vulnerability to chemicals.

Industrial applications of Pexgol pipes include transporting slurries; gypsum, sand, salt, phosphates, silts, potash, and various chemicals and industrial wastes.

A list of projects is available from our sales department or on our website, www.pexgol.com

Infrastructure

Pexgol Solutions for Infrastructure Applications

Infrastructure Applications

Golan Plastic supplies complete pipe systems for municipal services and industrial use. Contractor training is provided by Golan.

Pexgol Cold Water Supply Installation Guide

Complete water supply systems and industrial pipelines can be created by combining Pexgol pipes and electrofusion fittings. The Installation guide and the electrofusion welding instructions can be downloaded from our site.

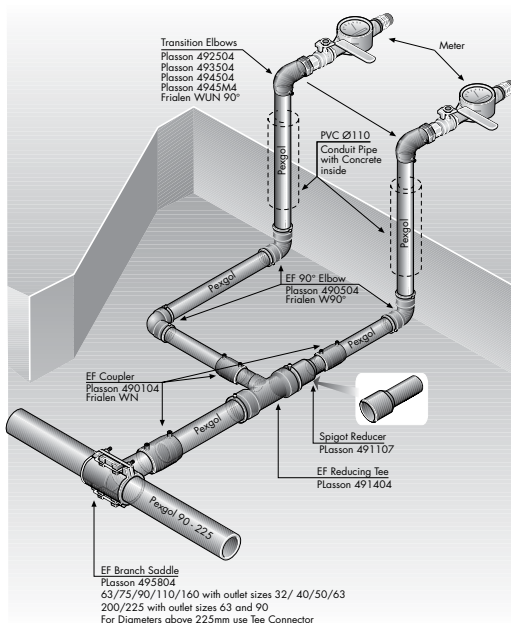

Pexgol lines for very low ambient temperatures

Specially designed pre-insulated Pexgol pipes can be installed above ground in very low ambient temperatures. Pexgol pre-insulated pipes are suitable for industrial and infrastructure applications.

Pexgol Fire Extinguisher Lines

Golan Plastic provides a complete solution with electrofusion fittings and it's own special hydrant outlets. The pipes are UL approved.

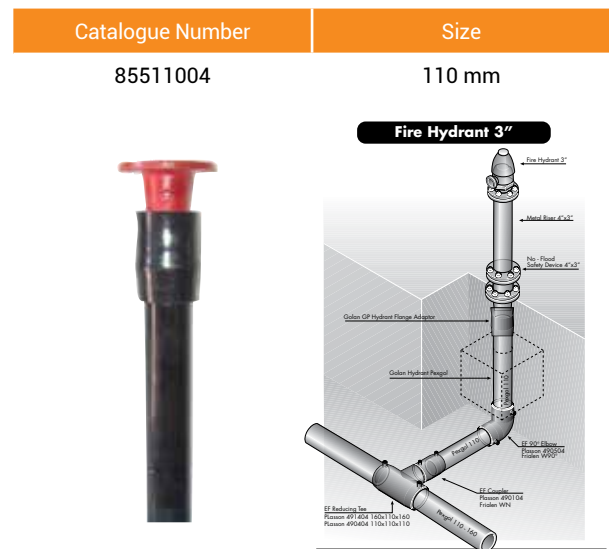

Natural Gas Pipes

Pexgol natural gas pipelines can be designed based on ISO14531 Pex pipes for gaseous fluids or the Australian standard: AS 2492.

The main advantages of Pexgol pipes for this application:

- Maximum service temperature: 60 °C
- Minimum service temperature: -50°C
- No sand bedding is needed

Pexgol natural gas pipes are usually connected by electrofusion fittings.

Air Supply Pressure Lines

Pexgol pipes must be designed with the correct design temperature. Recommended safety factor is 1.5.

All fittings types can be used, including brass.

Pexgol Pre-Insulated Pipes

The following table describes some of the Pexgol pre-insulated pipes that Golan supplies. The inner pipe is made of Pex-a natural material. The pipe can be EVOH coated in red, yellow, or other colours. Alternatively, it is supplied as a black pipe (UV resistant). The inner pipe can be single, a double-pipe combination, or a four-pipe combination (up to 63 mm), according to requirements.

The external corrugated layer is made of UV resistant black material. In cases of above-ground installation in extremely low ambient temperatures, the external corrugated layer can be made of Pex material.

The pipes are supplied with a heat-tracing element on special request.



Table 87.1: Pre-Insulated Pipes

Catalogue Number	Description	Insulation Wall thickness (mm)	Outside Diameter (mm)	Bending Radius (m)
90000-M9032C	THERMO-Pexgol a natural coated yellow single pipe 32 x 2.9 - 100 m	26	90	0.25
90000-M12540C	THERMO-Pexgol a natural coated red single pipe 40 x 3.7 - 100 m	40	90	0.30
90000-M12540S-1	THERMO-Pexgol a black single pipe 40 x 5.5 - 100 m	40	90	0.30
90000-M12550C	THERMO-Pexgol a natural coated yellow single pipe 50 x 4.6 - 100 m	53	125	0.40
90000-M16050S	THERMO-Pexgol a black single pipe 50 x 6.9 - 100 m	53	125	0.40
90000-M16063C	THERMO-Pexgol a natural coated yellow single pipe 63 x 5.8 - 100 m	45	125	0.50
90000-M16075C	THERMO-Pexgol a natural coated yellow single pipe 75 x 6.8 - 100 m	42	160	0.75
90000-M16075S	THERMO-Pexgol a black single 75 x 10.3 - 100 m	42	160	0.75
90000-M20090C	THERMO-Pexgol a natural coated red single pipe 90 x 8.2 - 100 m	48	160	1
90000-M20090S	THERMO-Pexgol a natural coated natural single pipe 90 x 12.3 - 100 m	48	160	1
90000-M200110C	THERMO-Pexgol a natural coated red single pipe 110 x 10 - 100 m	42	200	1.20

Note: Other sizes are available on request.

Residential

Pexgol Solutions for Hot and Cold Water

Golan supplies regular and pre-insulated pipe systems for district heating: transporting hot and cold water from central systems to buildings. The pre-insulated pipes maintain the heat even under extremely cold ground conditions and transport hot and cold water in long, continuous pipelines. Company engineers are available to assist in system design (pipes and fittings).

1. Brass saddle
2. GP bolt connector
3. Tee female DZR brass
4. 90 1.5 D Pexgol elbow
5. Reinforced electrofusion coupler
6. Special Pex-lined steel fitting
7. GP flanged coupling
8. Hela 8047 reducing tee

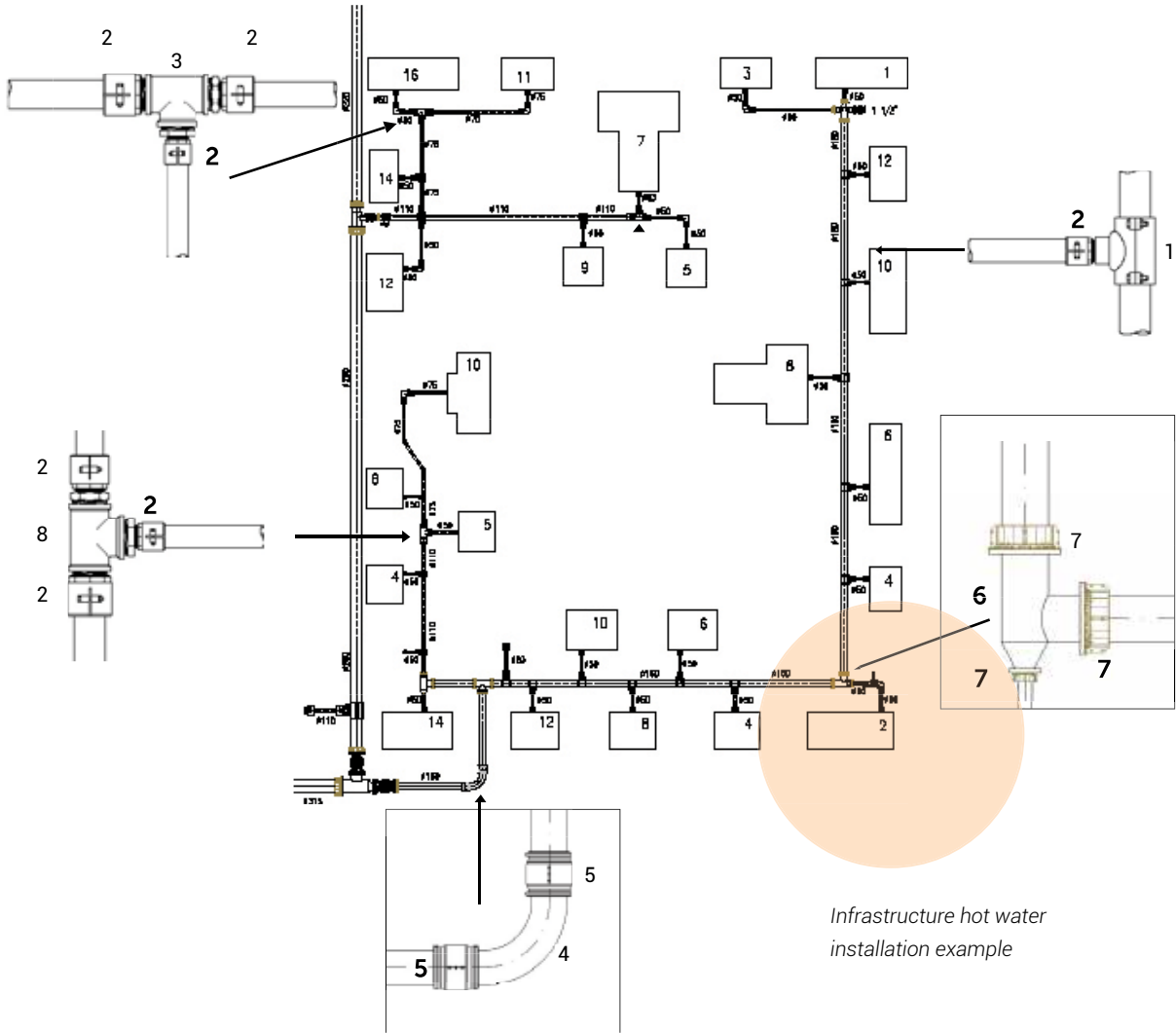

Infrastructure hot water installation example

Exemplo de instalação de tubulação ascendente

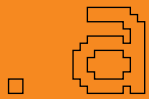
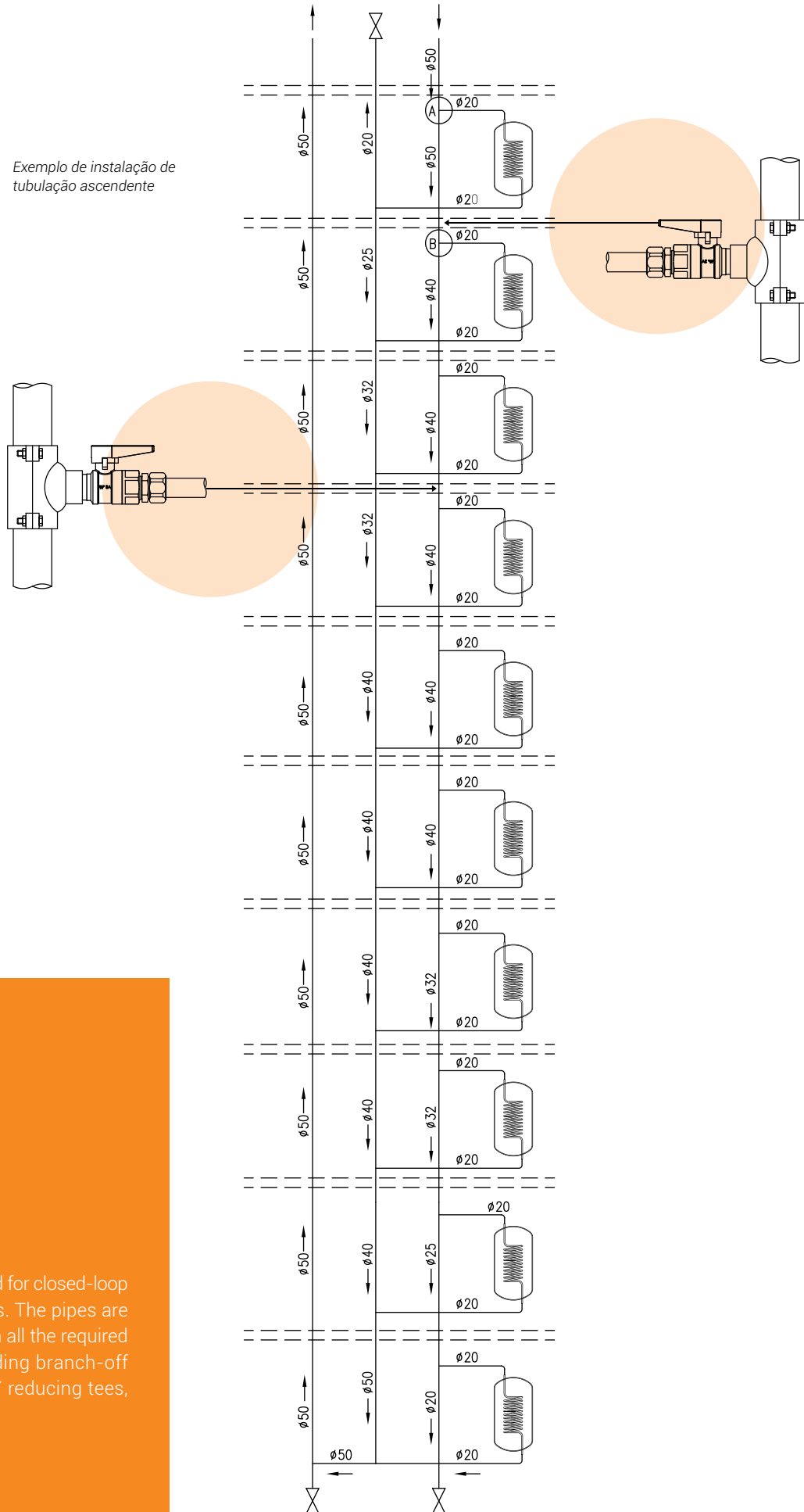

Hot Water Risers

Pexgol pipes are used for closed-loop and open-loop risers. The pipes are supplied in coils with all the required brass fittings including branch-off saddles, HELA 8047 reducing tees, and more.



Transportation of Pexgol Pipes





Index

Transportation of Pexgol Pipes in
Coils

Transportation of Pexgol Pipes in
Coils with Cores

Transportation of Pexgol Pipes in
Straight Sections

Transportation of Pexgol Pipes

1. Transportation of Pexgol Pipes in Coils

Pexgol pipes of diameters from 40 to 280 mm are available in coils for shipping in coils. From 40 mm to 160 mm can be fitted on 20' and 40', 20' and 40' OT, and 40' HC containers. From diameters of 180 up to 280 mm, on containers of 20' and 40' OT.

Table 92.1: Transport of Pexgol Pipes with Wiameters from 40 to 160 mm

Pipe		20' and 40' containers			40' containers		Open Top Containers		
Outside Diameter (mm)	Class	Max. Length per coil (m)	20' number of coils	40' number of coils	Max. Length per coil (m)	40' HC number of coils	Max. Length per coil (m)	20' OT number of coils	40' OT number of coils
40	15	1800	5	11	2100	10	N/A	N/A	N/A
40	19	1800	5	11	2100	10	N/A	N/A	N/A
40	24	1800	5	11	2100	10	N/A	N/A	N/A
40	30	1800	5	11	2100	10	N/A	N/A	N/A
50	15	1200	5	11	1400	10	N/A	N/A	N/A
50	19	1200	5	11	1400	10	N/A	N/A	N/A
50	24	1200	5	11	1400	10	N/A	N/A	N/A
50	30	1200	5	11	1400	10	N/A	N/A	N/A
63	10	600	5	11	800	10	N/A	N/A	N/A
63	12	600	5	11	800	10	4500	1	3
63	15	700	5	11	800	10	4500	1	3
63	19	700	5	11	800	10	4500	1	3
63	24	700	5	11	800	10	4500	1	3
63	30	700	5	11	800	10	4500	1	3
75	10	300	5	11	450	10	N/A	N/A	N/A
75	12	450	5	11	500	10	3300	1	3
75	15	500	5	10	500	10	3300	1	3
75	19	500	5	10	500	10	3300	1	3
75	24	500	5	10	500	10	3300	1	3
75	30	500	5	10	500	10	3300	1	3
90	10	200	5	11	300	8	N/A	N/A	N/A
90	12	250	5	11	350	8	2000	1	3
90	15	300	5	10	400	8	2000	1	3
90	19	300	5	10	400	8	2000	1	3
90	24	300	5	10	400	8	2000	1	3
90	30	300	5	10	400	8	2000	1	3
110	12	130	5	11	210	8	1300	1	3
110	15	250	5	9	300	8	1300	1	3
110	19	250	5	9	300	8	1300	1	3
110	24	250	5	9	300	8	1300	1	3
110	30	250	5	9	300	8	1300	1	3

Table 92.1 (Continue): Transport of Pexgol pipes with diameters from 40 to 160 mm

Pipe		20' and 40' containers			40' HC containers		Open Top Containers		
Outside Diameter (mm)	Class	Max. Length per coil (m)	20' number of coils	40' number of coils	Max. Length per coil (m)	40' HC number of coils	Max. Length per coil (m)	20' OT number of coils	40' OT number of coils
125	12	75	5	11	120	8	1000	1	3
125	15	150	5	10	200	8	1000	1	3
125	19	150	5	10	200	8	1000	1	3
125	24	150	5	10	200	8	1000	1	3
125	30	150	5	10	200	8	1000	1	3
140	12	N/A	N/A	N/A	85	8	760	1	3
140	15	80	5	11	125	8	900	1	3
140	19	N/A	N/A	N/A	170	4	900	1	3
140	24	N/A	N/A	N/A	170	4	900	1	3
140	30	N/A	N/A	N/A	170	4	900	1	3
160	10	N/A	N/A	N/A	N/A	N/A	450	1	3
160	12	N/A	N/A	N/A	N/A	N/A	620	1	3
160	15	N/A	N/A	N/A	150	4	620	1	3
160	19	N/A	N/A	N/A	150	4	620	1	3
160	24	N/A	N/A	N/A	150	4	620	1	3
160	30	N/A	N/A	N/A	150	4	620	1	3

OT - Open Top Container / HC - High Cube

Table 93.1: Transport of Pexgol pipes with diameters from 180 to 280 mm

Pipe		Max. Length per coil (m)	Number of coils	
Outside Diameter (mm)	Class		20' number of coils	40' number of coils
180	12	400	1	3
180	15	450	1	3
180	19	500	1	3
180	24	500	1	3
180	30	500	1	3
200	12	270	1	3
200	15	350	1	3
200	24	350	1	3
200	30	350	1	3
225	12	176	1	3
225	15	245	1	3
225	19	245	1	3
225	24	300	1	3
225	30	300	1	3
250	15	150	1	3
250	19	200	1	3
250	24	250	1	3
250	30	230	1	3
280	15	125	1	3



Table 94.1: Coils dimensions for transporting Pexgol pipes

Pipe		Standard coil (20' and 40' container)				Tall coil (40' high cube container)			
Outside Diameter (mm)	Class	Length (m)	ID (mm)	Outside Diameter (mm)	W (m)	Length (m)	ID (mm)	Outside Diameter (mm)	W (mm)
40	10	1,500	1,250	2,150	950	2,000	1,200	2,400	1,000
40	15	1,800	1,050	2,200	1,050	2,100	1,200	2,400	1,050
40	19	1,800	1,050	2,200	1,050	2,100	1,200	2,400	1,050
40	24	1,800	1,050	2,200	1,050	2,100	1,200	2,400	1,050
40	30	1,800	1,050	2,200	1,050	2,100	1,200	2,400	1,050
50	15	1,200	1,050	2,200	1,050	1,400	1,050	2,400	1,050
50	19	1,200	1,050	2,200	1,050	1,400	1,050	2,400	1,050
50	24	1,200	1,050	2,200	1,050	1,400	1,050	2,400	1,050
50	30	1,200	1,050	2,200	1,050	1,400	1,050	2,400	1,050
63	10	600	1,200	2,200	1,050	800	1,200	2,400	1,050
63	12	600	1,200	2,200	1,050	800	1,200	2,400	1,050
63	15	700	1,100	2,200	1,050	800	1,100	2,400	1,050
63	19	700	1,100	2,200	1,050	800	1,100	2,400	1,050
63	24	700	1,100	2,200	1,050	800	1,100	2,400	1,050
63	30	700	1,100	2,200	1,050	800	1,100	2,400	1,050
75	10	300	1,450	2,200	1,000	450	1,450	2,400	1,050
75	12	450	1,200	2,200	1,050	500	1,200	2,400	1,050
75	15	500	1,050	2,200	1,050	500	1,100	2,400	1,050
75	19	500	1,050	2,200	1,050	500	1,100	2,400	1,050
75	24	500	1,050	2,200	1,050	500	1,100	2,400	1,050
75	30	500	1,050	2,200	1,050	500	1,100	2,400	1,050
90	10	200	1,550	2,200	1,000	300	1,550	2,450	1,000
90	12	250	1,300	2,200	1,000	350	1,300	2,500	1,000
90	15	300	1,150	2,200	1,050	400	1,300	2,500	1,000
90	19	300	1,050	2,200	1,050	400	1,300	2,500	1,000
90	24	300	1,050	2,200	1,050	400	1,300	2,500	1,000
90	30	300	1,050	2,200	1,050	400	1,300	2,500	1,000
110	12	130	1,650	2,250	1,000	210	1,700	2,550	1,000
110	15	250	1,150	2,250	1,000	300	1,100	2,550	1,000
110	19	250	1,150	2,250	1,000	300	1,100	2,550	1,000
110	24	250	1,150	2,250	1,000	300	1,100	2,550	1,000
110	30	250	1,150	2,250	1,000	300	1,100	2,550	1,000
125	12	75	1,800	2,250	1,000	120	1,800	2,550	1,000
125	15	150	1,250	2,250	1,050	200	1,250	2,450	1,050
125	19	150	1,250	2,250	1,050	200	1,250	2,450	1,050
125	24	150	1,250	2,250	1,050	200	1,250	2,450	1,050
125	30	150	1,250	2,250	1,050	200	1,250	2,450	1,050
140	12	N/A	N/A	N/A	N/A	70	1,900	2,450	1,000
140	15	75	1,650	2,200	1,000	120	1,650	2,450	1,000
140	19	75	1,650	2,200	1,000	120	1,650	2,450	1,000
140	24	75	1,650	2,200	1,000	120	1,650	2,450	1,000
140	30	75	1,650	2,200	1,000	120	1,650	2,450	1,000
160	15	N/A	N/A	N/A	N/A	70	1,850	2,450	1,000
160	19	N/A	N/A	N/A	N/A	140	1,850	2,500	2,000
160	24	N/A	N/A	N/A	N/A	140	1,850	2,500	2,000
160	30	N/A	N/A	N/A	N/A	140	1,850	2,500	2,000

2023

Transportation of Pexgol Pipes

2. Transportation of Pexgol Pipes with Coils with Cores

Pexgol pipes are available in special coils with cores. Delivery without cores is possible, after consulting with Golan's application engineers.

Table 95.1: Pipes in coils with cores

Pipe		Max. length per coil (m)	No. of coils allowed	
OD (mm)	Class		20' OT container	40' OT container
280	19	140	1	3
280	24	190	1	3
280	30	190	1	3
315	15	65	1	3
315	19	120	1	3
315	24	120	1	3
315	30	120	1	3
355	15	N/A	N/A	N/A
355	19	52	1	3
355	24	95	1	3
355	30	95	1	3



3. Transportation of Pexgol pipes in straight sections

Pexgol pipes in larger diameters from 315 mm up to 710 mm with plain ends can be ordered in straight bars a maximum length of 11.8 m each (to fit into standard 40 ft containers).

Table 95.2 & 95.3: Pipes in straight sections on 40' and 40' HC containers

Pipe Outside Diameter (mm)	Sections in 40' container	
	Units 11.8 [m]	Total [m]
63	1,385	16343
75	944	11139
90	588	6938
110	408	4814
125	298	3516
140	248	2926
160	175	2065
180	150	1770
200	116	1369
225	86	1015
250	77	906
280	60	708
315	46	543
355	33	389
400	27	319
450	23	271
500	20	236
630	9	106
710	9	106

Pipe Outside Diameter (mm)	Sections in 40' HC container	
	Units 11.8 [m]	Total [m]
63	1,385	16343
75	944	11139
90	614	7245
110	431	5086
125	312	3682
140	250	2950
160	186	2195
180	151	1782
200	118	1392
225	93	1097
250	77	909
280	60	708
315	47	555
355	39	460
400	30	354
450	24	283
500	20	236
630	12	141
710	9	106



Application Questionnaire

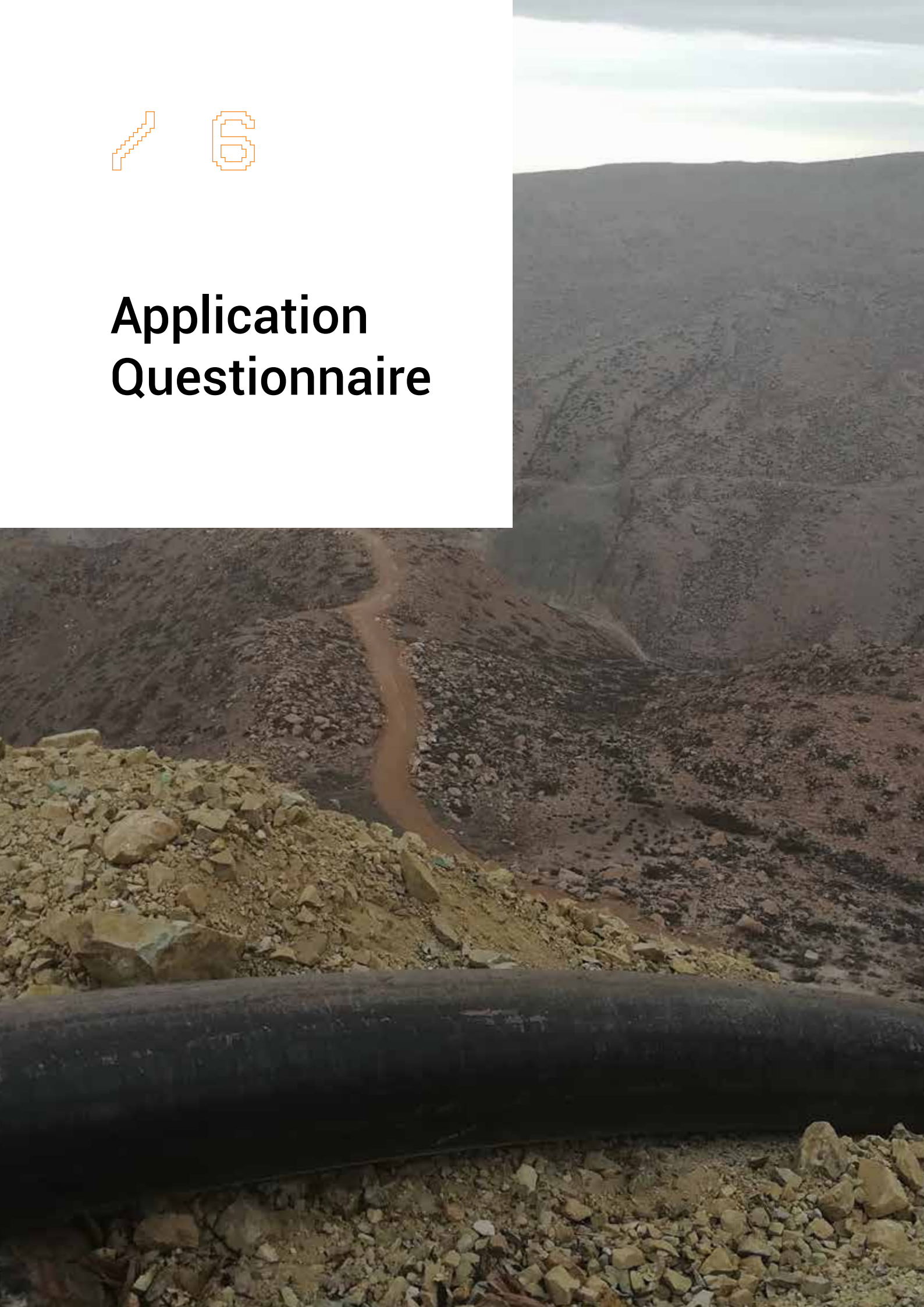



Index

Newtonian Fluids

Boreholes & Dewatering

Slurry

Conversion Tables

Application Questionnaire (RFI)

Golan Plastic Products is keen to find the right solution for any application. The solution is always a combination of the right pipe class and the right choice of fitting. To select the right solution for you application, we ask you to please complete the relevant Application Questionnaire and send it to us. Please answer the following questions to the best of your knowledge and select the proper measurement units.

Newtonian Fluids

Please answer the following questions to the best of your knowledge/Select the proper units		
Type of transported material		
Chemical composition		
Concentration (%)		
Specific gravity (gr/cm ³) (lb/ft ³)		
Fluid temperature (°C) (°F)		
Maximum environmental temperature (°C) (°F)		
Is the pipe exposed above the ground?	Yes	No
Is the fluid abrasive?	Yes	No
Required flow rate (m ³ /h) (gpm)		
Pump pressure (bar) (psi)		
Line length (m) (ft)		
Current pipe material		
Current pipe outside diameter (mm) (in)		
Current pipe inside diameter (mm) (in)		
Altitude difference on the pipe (m) (ft)		
Line going up	Line going down	
Final discharge pressure of the pipe system (bar) (psi)		
Minimum critical speed of the slurry (m/s) (ft/s)		

Note: Please attach any additional information such as layout sketches, field outline, pump brand and model (if it's already selected), specifications page, etc.

Boreholes & Dewatering

Please answer the following questions to the best of your knowledge/Select the proper units		
H= Minimum dynamic water level (m) (ft)		
L= Depth of installation (pipe length) (m) (ft)		
Required flow rate (m ³ /h) (gpm)		
Discharge pressure (*) (bar) (psi)		
Water temperature (°C) (°F)		
Pump pressure at closed valve (bar) (psi)		
Pump weight (kg) (lb)		
Weight of wiring (kg/m) (lb/ft)		
Pump connection size	Flange	Thread
Pump construction material		
Interior coating dimension (ID) (mm) (in)		

* Required pressure at the borehole outlet.

Note: If you already selected the pump, please send brand and model.

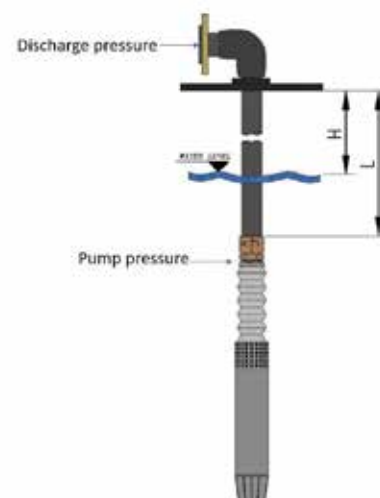

Slurry

Please answer the following questions to the best of your knowledge/Select the proper units		
Slurry to transport		
Flow	m ³ /h	gpm
Chemical composition		
pH		
Specific solids gravity	S	
Concentration	(%)	
Fluid temperature	°C	°F
Slurry density	kg/m ³	g/cm ³
Dynamic viscosity	Pa·s	Pa·s
Yield stress (T0)	Pa	
d.50	mm	µm
d.85	mm	µm
Critical velocity	m/s	ft/s
Is the pipe exposed above the ground?	Yes	No
Maximum environmental temperature	°C	°F
Altitude difference on the pipe	m	ft
Line length	m	ft
There's a selected pump?	Yes	No
Current pump pressure	bar	psi
There's a current working pipe?	Yes	No
Current pipe material		
Current pipe outside diameter	mm	in
Current pipe inside diameter	mm	in
Expected service life		Years

Note: Please attach any additional information such as layout sketches, field outline, pump brand and model (if it's already selected), specifications page, etc.

Conversion Tables

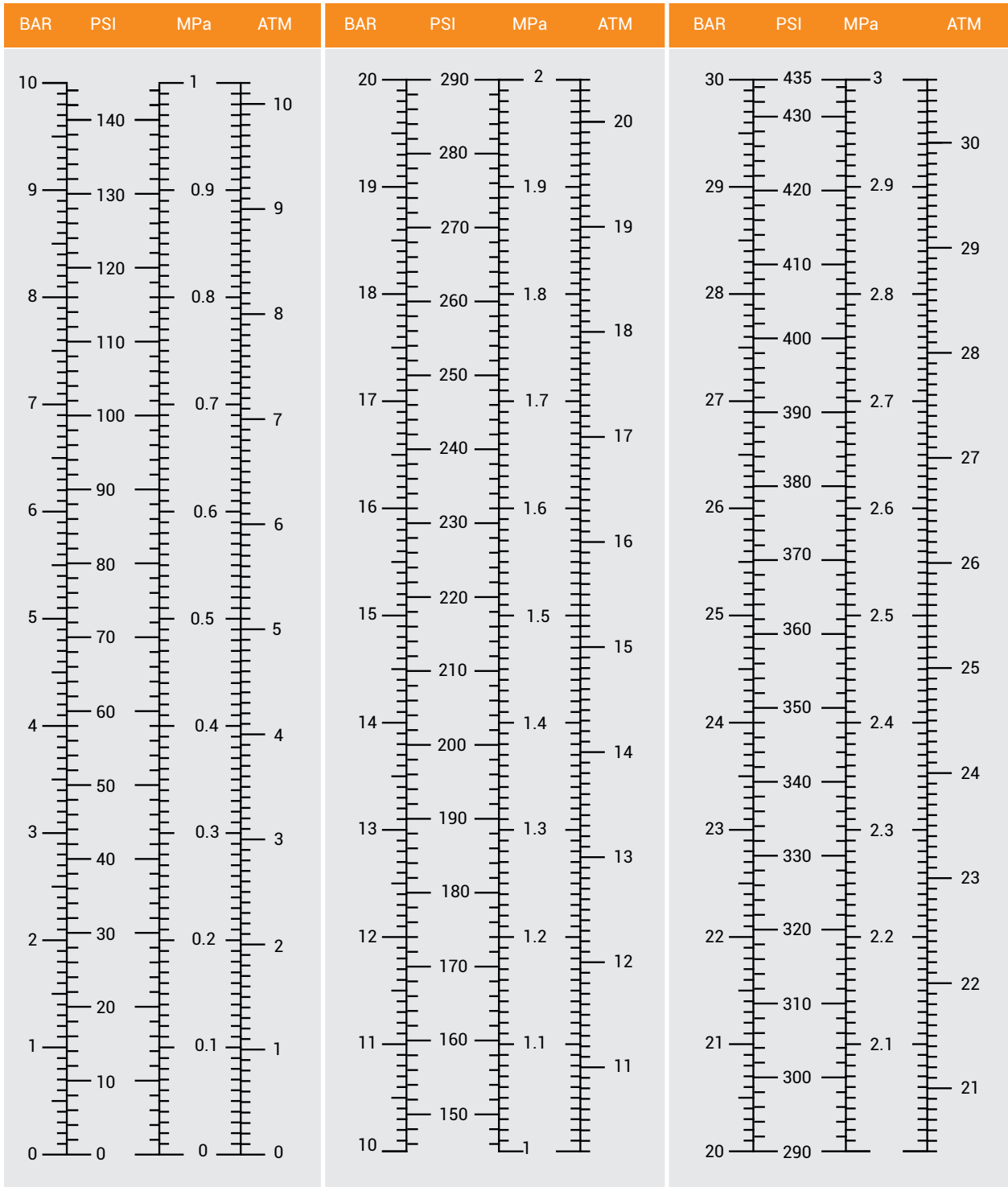

2023

Application Questionnaire

Unit	Inches	Feet	Millimetres	Metres
Inches	1	0.08	25.4	0.0254
Feet	12	1	304.8	0.3048
Yards	36	3	914.4	0.9144
Miles	63.360	5.280	1609x103	1609.34
Millimetres	0.039	0.47	1	1000
Metres	39.37	3.28084	0.001	1

Flow

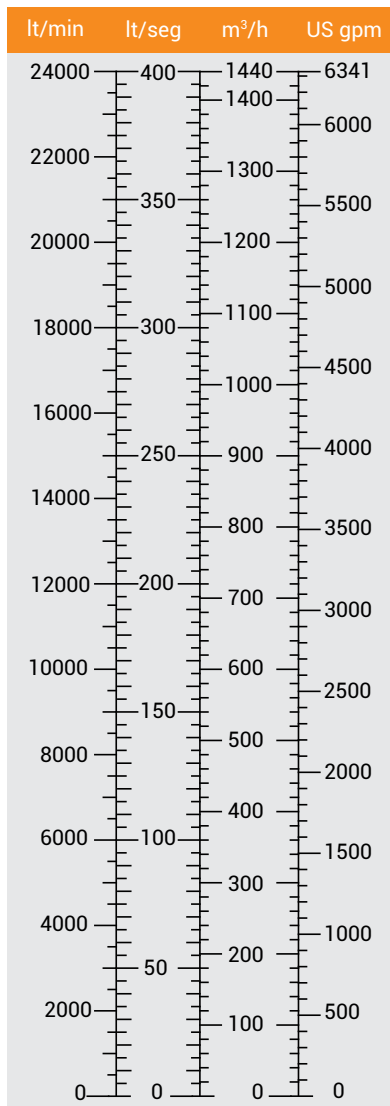

Temperature

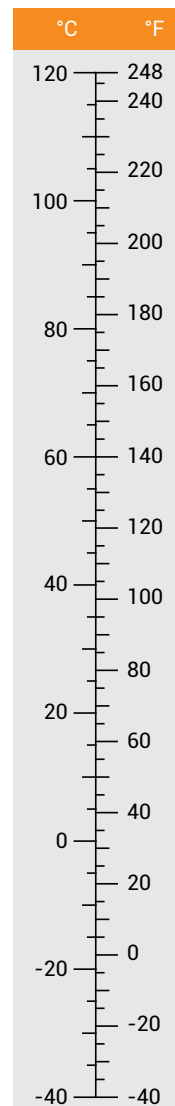

Quantity	SI (Metric) Unit	Equal US Customary Unit
Length	metre (m)	3.281 feet (ft)
	metre (m)	39.37 inches (in.)
	millimetre (mm)	0.03937 inches (in.)
Area	square metre (m ²)	10.76 ft ²
	square metre (m ²)	1550 in. ²
	square millimetre (mm ²)	0.001550 in. ²
Volume	cubic metre (m ³)	35.31 ft ³
	cubic metre (m ³)	264.2 gallons (gal)
	litre	0.03531 ft ³
	litre	61.02 in. ³
	litre	0.2642 gal
Mass	kilogramme (kgm)	2.205 pounds mass (lbm)
Force	Newton (N)	0.2248 pounds force (lbf)
Pressure	Pascal (PA) or (N/M ²)	1.450x10 ⁻⁴ lbf/in ² (psi)
	MegaPascal (MPa) or N/mm ² bar	1.450x10 ² lbf/in ² (psi)
	Kilopascal (kPa) or (kN/m ²)	14.504 lbf/in ² (psi)
	Kilogramme-force/square centimetre (kgf/cm ²) or kilopond (kp/cm ²)	0.1450 lbf/in ² (psi)
		14.223 lbf/in ² (psi)
Enthalpy	Joule/gramme (j/g)	0.4299 Btu/lbm
Temperature	Kelvin (k)	1.800° Rankine (°R)
	Kelvin (k)	1.8K - 459.67=°Fahrenheit (°F)
	°Celsius (°C)	1.8°C + 32 = °F



Fittings

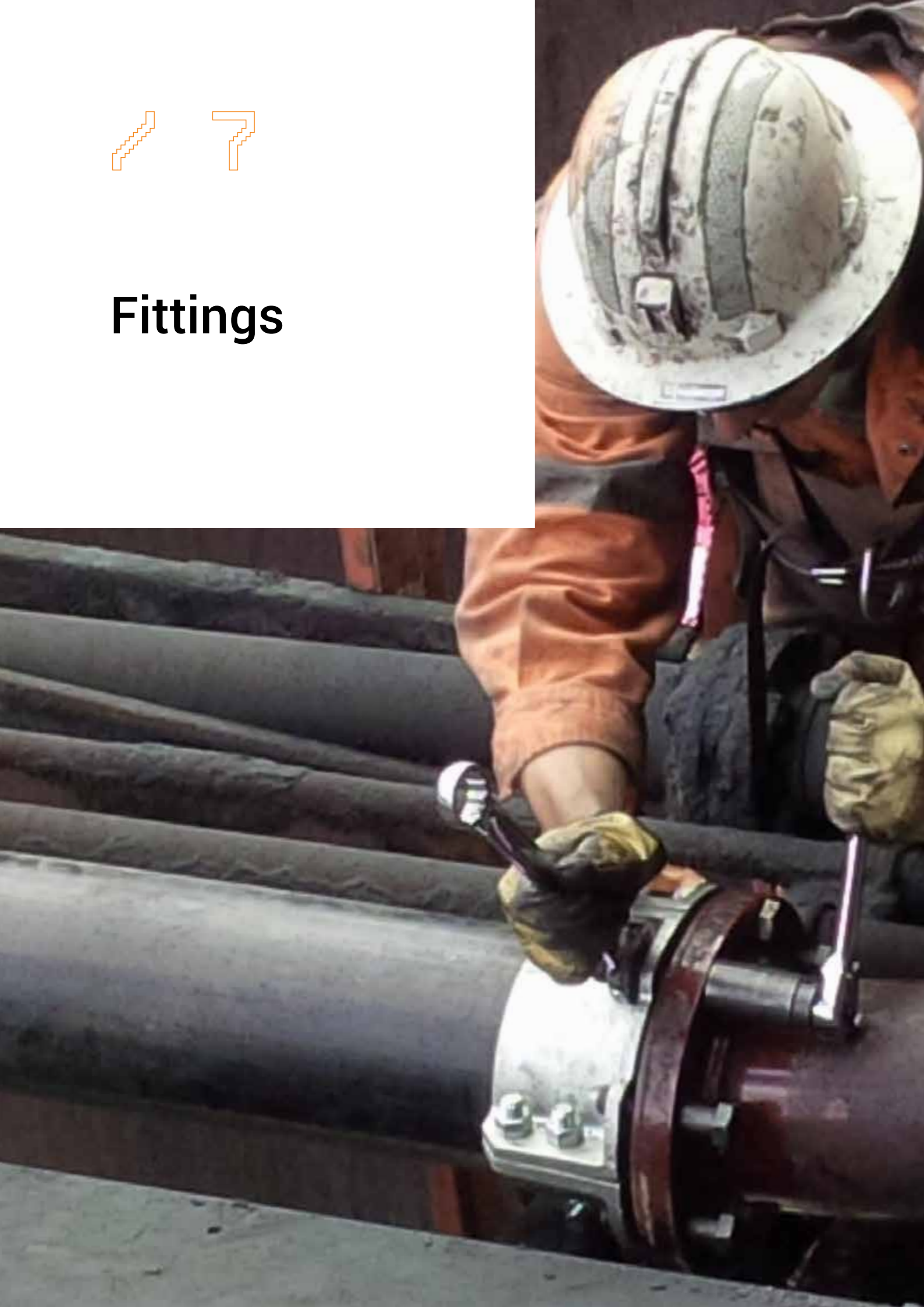



Index

Non-Restrained Fittings and Pullout
Prevention Techniques

Fixpoint Clamp

Floating Fixpoint Devices

PE100 Electrofusion Fittings

Reinforced Electrofusion Couplers

PE-X Lined Fittings

Brass Fittings for Pexgol Pipes
Class 15 & 24

Branch-Off Saddles

PE-Xa Pexgol Elbows

PE-Xa Flared End Connectors

Compatibility of Pexgol Flanges

PE-Xa Short Sections with Two
Flared Ends

PE-Xa Spigot Reducers

Pexgol Reducers with Flared Ends
and Flanges

PE-Xc ID Adaptor/Spacer

Pexgol Instrument Tees & Water
Flushing Ports

Pexgol Transition Flange

Flange Couplers for Pexgol Pipes

Fixpoint Clamps

Fixpoint Bridge

Non-Restrained Fittings and Pullout Prevention Techniques

Buried Pexgol pipes and their approved fittings are self-restrained and require no thrust blocking.

Thrust blocks are used to support fire hydrants. Concrete pads are used under metal valves to reduce settlement.

Anchor blocks are used when a Pexgol pipe is to be connected to other pipe materials that use bell and spigot connections unless these connections are themselves restrained to prevent pullout.

Generally, it is necessary to anchor the ends of a Pexgol pipeline that transitions into an unrestrained joint pipe system.

Design of wall anchors and thrust blocks

A typical anchoring technique is installing a fixpoint clamp or a GP flanged coupling on the pipe close to the wall, and pouring concrete around it.

The non-restrained fittings

A different situation occurs in certain applications where axial forces which are present in the pipe may pull out the pipe from non-restrained joints.

The axial forces may be a result of the following:

- Thermal deflection (contraction) due to temperature variations.
- Ground movement and earthquakes.
- Hoop expansion: The internal pressure hoop expands the diameter (ever so slightly) and tends to contract the pipe length in proportion to Poisson's Ratio.

In dewatering or borehole applications, additional longitudinal forces might be present due to the weight of the pipeline, the weight of the water column, or pump weight. These axial forces could result in pulling out the pipe from a gasket joint or a complete pulling out of the Pexgol pipe from the fitting.

Buried Applications

All Pexgol's fittings that are approved for buried applications are considered as restrained connections and they do not require any pull-out prevention method in buried applications.

Above ground applications

For the applications of horizontal pipelines and inclined pipelines (including dewatering lines) with a slope of up to 40°, the following fittings are restrained by the ground and therefore are considered as restrained connections and do not require any pull-out prevention method:

- Electrofusion fittings
- Hela bolt connectors
- Branch-off saddles

The following fittings are considered as unrestrained connections for above ground applications, and they require a pullout prevention technique:

- Flanged couplers
- Pexgol flared end connectors
- Victaulic PE couplers
- Aquafast couplers

For dewatering applications and inclined pipeline with slope over 40°, all Pexgol fittings are considered as unrestrained connections, and they require a pull-out prevention technique.

Borehole Applications

This is a special application requiring special constrained fittings and consulting.

Pullout prevention methods and devices

1. Fixpoints: Unrestrained fitting should be protected from pull-out by creating a fixpoint before and after each fitting using our fixpoint clamps (see pages 105 & 106).

2. Floating fixpoint device: In some applications (like dewatering or inclined pipelines)

it might be costly or problematic to install fixpoints in the line.

In that case, if you have of a non-restrained fitting which requires a pullout prevention device, it might be easier to replace the two fixpoints by a floating fixpoint device. A floating fixpoint device is actually two restraining fittings that are installed before and after the non-restrained fitting. Restraining a non-restrained fitting is achieved by connecting two restraining fitting so that the axial forces can be transferred through the device while bypassing the non-restrained fitting.

The pictures on page 101 show a few arrangements for a floating fixpoint device, including our fixpoint bridge (see pagess 134 & 160).

In cases of industrial installation over pipe supports, it is usually feasible to use the fixpoint clamps as pull-out prevention devices. However, in cases where the Pexgol pipe is connected to a steel pipe by a non-restrained fitting, it might be convenient to use the fixpoint bridge and install one clamp directly on the steel pipe.

Alternatively, a combination of a back-flange and a fixpoint clamp can be used together with the existing steel flange.

Fixpoint Clamp

The fixpoint clamp is a standard item from Golan. It is available for all pipe diameters from 63 mm. For more details (see "Fixpoint Clamps in the Fittings Catalogue).

The drawings show a double flared-ends connection or a double flanged coupling connection protected from pull-out by two fixpoint clamps. The solid blue lines represent a part of the construction that is not supplied by Golan.



Image: Double flared-ends connection with two fixpoint clamps

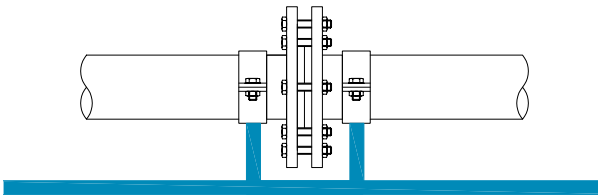

Image: Double flanged coupling with two fixpoint clamps

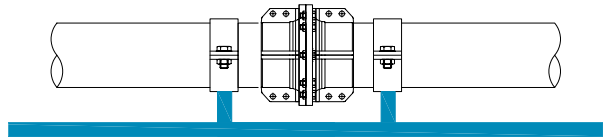

Image: Anchoring block using a fixpoint clamp

Anchoring the pipeline along the line (for example, in case of sea outfall lines) is achieved by casting concrete on a fixpoint clamp.

A Flex Restraint electrofusion fitting by Plasson can be used to replace the fixpoint clamp.

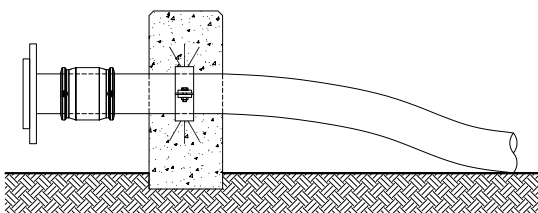
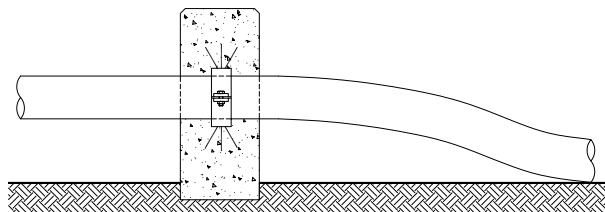

Image: Anchoring the pipe end

Anchoring the end of an inclined pipeline (for example, in the case of dewatering lines) is necessary for restraining the weight of the inclined pipeline.

Floating fixpoint devices

The central mechanical fitting is protected from pullout by two external fittings operating in tandem with two loose flanges. Before connecting the central fitting, a loose flange is mounted over the pipe and then the external fitting is mounted over the pipe, far enough from the pipe end to allow the central fitting to be mounted later.

The axial forces are transmitted from one flange to the other flange through the threaded bars. The central fitting as well as the external fittings in the picture are Victaulic connectors but they can be replaced by flanged couplers or any other type of mechanical connectors approved for Pexgol pipes.

Image: Floating fixpoint devices using two mechanical fitting

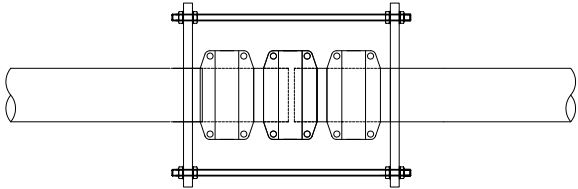

The central mechanical fitting is protected from pull-out by two external electrofusion fittings operating in tandem with two loose flanges. Before connecting the central fitting, a loose flange is mounted over the pipe and then the external electrofusion fitting is mounted over the pipe, far enough from the pipe end to allow the central fitting to be mounted later.

The axial forces are transmitted from one flange to the other flange through the threaded bars. The central fitting in the picture is a flared end connector, but it could be a flanged coupling or any other mechanical connector.

Image: Floating fixpoint devices using two loose flanges and two electrofusion couplers

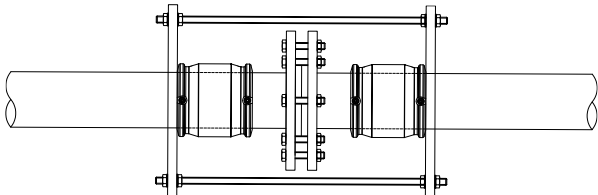

The floating fixpoint device in this picture is called a fixpoint bridge. It has two fixpoint clamps that replace the two external fittings and the two loose flanges in the previous pictures.

Image: Floating fixpoint devices using a fixpoint bridge and two electrofusion fitting

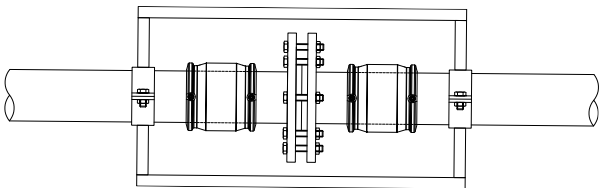

The two fixpoint clamps are connected by a steel frame that replaces the threaded bars in the previous pictures. For more details see "Fixpoint Bridge" section. The fixpoint bridge is a standard item available by ordering from Pexgol's fittings catalogue.

Image: GP fixpoint bridge

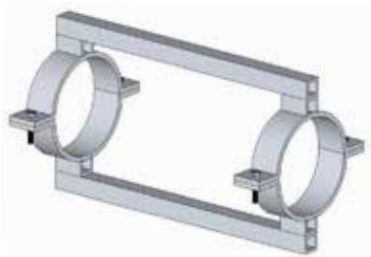

PE100 Electrofusion Fittings

Electrofusion fittings are used to connect Pexgol cross-linked polyethylene pipes.

The pipes and fitting are joined by electrofusion welding, creating a leak-proof seal. During the electrofusion process, a current is transported through a heating wire. The surrounding material (around the wire) is melted, welding the pipe to the fitting. Service temperature for the PE 100 electrofusion fittings is limited to 40°C. For higher temperatures reinforced electrofusion couplers can be used.



Golan approves and supplies the following fittings systems and installation tools: **Plasson, Friatec and GF/Wavin.**

	Group	Range
	Couplers	20 to 710 mm
	Branch saddles	63 to 710 mm
	Elbows	20 to 250 mm
	Tees & Reducing tees	20 to 250 mm
	Reducing couplers	20 to 180 mm
	End cups	20 to 315 mm
	Flange adaptors	20 to 400 mm
	PP coated flanged backing ring	20 to 400 mm
	Transition couplers	20 to 110 mm
	Tapping saddles	40 to 250 mm
	Electrofusion control boxes & Installation tools	www.plasson.com www.friatec.com www.gfps.com
	Non-standard & custom-made items	

Reinforced Electrofusion Couplers

Electrofusion couplers for high pressure and temperature applications

In order to extend the service range of the standard electrofusion couplers, the Pexgol system also includes a special range of Reinforced Electrofusion Couplers Series 1, as well as a special reinforcement kits for reinforcing standard PE 100 Electrofusion couplers.

The reinforced electrofusion couplers are compatible with all Pexgol pipes in class 30 SDR 6 in the temperature range from -30° to 70°C and the full pressure ranges of this pipe class.

High temperature electrofusion couplers solution up to 90°C

When higher working conditions are required, for which Reinforced Electrofusion Couplers Series 1 are not available, please consult Golan's Application Team.



Table 108.1: Reinforced Electrofusion Coupler Series 1 sizes 63~140

Catalogue Number Coupler	Catalogue Number Reinforcement	Pipe Diameter (mm)
190104063	3PLO63	63
190104075	3PLO75	75
190104090	3PLO90	90
190104110	3PL110	110
190104125	3PL125	125
190104140	3PL140	140

Table 108.2: Reinforced Electrofusion Coupler Series 1 sizes 160~630

Catalogue Number Coupler with Reinforcement	Pipe Diameter (mm)
EFR1-000160	160
EFR1-000180	180
EFR1-000200	200
EFR1-000225	225
EFR1-000250	250
EFR1-000280	280
EFR1-000315	315
EFR1-000355	355
EFR1-000400	400
EFR1-000450	450
EFR1-000500	500
EFR1-000560	560
EFR1-000630	630
EFR1-000710	710

PE-Xc Fittings

Standard PE-Xc fittings (Tees, Elbows, Reducers) are compatible to Class 15 Pexgol pipes, for temperature conditions up to 90°C.

Standard dimensions can be found in the product page for each fitting.

In special cases, custom-made dimensions can be provided per project requirements.

End connection fittings can be provided with plain ends for electrofusion welding or other mechanical couplers, in addition to stub end possibility for a loose flanged connection.

Notes:

- PE-Xc fittings include: Equal Tees, Reducing Tees, Lateral Tee, 45° Elbows, 90° Elbow, Concentric Reducers.
- In some cases, higher class PE-Xc fittings can be approved. Please consult with the Pexgol Application Team.
- Manufacturing process of PE-Xc fittings may include injected or mitered fittings.



PE-X Lined Fittings

PE-X lined steel fittings consist of a steel flanged fitting lined with thick black Pex coating which extends over the full face of the flanges. This type of fitting can be used as a standard fitting such as a Tee, an elbow, or a reducer. The fittings are supplied with an external epoxy coating. Standard fittings are supplied with wall thickness of PE-X layer: 3 – 5 mm for corrosion resistance and up to 10 mm for abrasion resistance.

The fittings are usually supplied with weld-neck flanges. Loose flanges are supplied on request. Shorter fittings (with slip-on flanges instead of weld-neck flanges) are supplied on request.

The elbows in the "Fittings Catalogue" are 1.5XD elbows. Long-radius (3XD) elbows or elbows with a larger radius can be supplied upon request. The minimum length of each fitting is indicated in the "Fittings Catalogue". This length can be reduced after consulting Golan.

It is possible to order a non-standard fitting, which is a combination of standard fittings, or a standard fitting with longer legs. For maximum allowable length, consult the application engineer.

Golan supplies straight sections of steel Pex-lined pipes as well, between Pex-lined fittings, in order maintain the same ID on the line. Alternatively, Golan supplies Pexgol pipes with the same or similar ID, or Pexgol reducers to match the ID.

Service temperature limits, subject to compatibility with the fluid being handled are:

PE-X: -30° to +90°C

Teflon: Up to 110°C

For more information see Page 62 "Gasket use recommendation in Pexgol pipe systems".

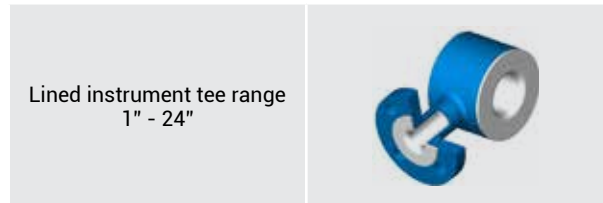
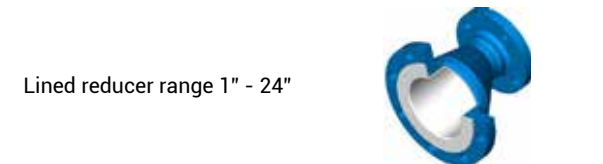
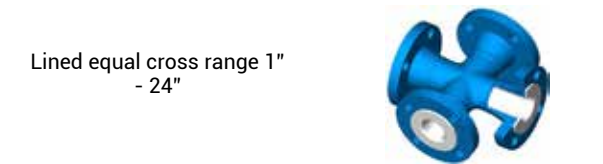

Specifications

These specifications cover materials, manufacturing, testing, inspection and packaging standards for standard and custom made PE-X lined fittings.

PE-X lined steel fittings consist of a steel flanged fitting lined with thick black PE-X coating which extends over the full face of the flanges. This type of fitting is used as a standard fitting (Tee, elbow, reducer, etc.). Non-standard items can also be supplied, subject to approval by Golan's technical department.

Manufacturing materials

All materials used are traceable to origin and records are maintained for a minimum of three years. When specified, material and/or test certificates is supplied.

PE-X lining

PE-X lining is made from resin conforming to the requirements of materials as defined in ASTM specification D1998-04.

The lining is made from virgin resin, meeting the requirements of ASTM D1998-04.

When tested in accordance with ASTM D638, the minimum tensile strength is 23 N/mm² and the minimum elongation is 300%.

Fittings

Fabricated fittings are manufactured from the materials stated above.

Cast fittings are manufactured from the following:

- Ductile iron – ASTM A395, BS2789 grade 420/12 or DIN 1693 Part 1 GGG40.
- Cast steel – ASTM A216 WCB or equivalent.
- Flanges and welding – neck collars are forged steel to ASTM A105 N.
- Slip on welding collars are steel plate to BS1501-161-430A, DIN 17100 grades RSt 37-2 or NF A 35-501 grade E24, EN 10025 or equivalent.

Fabrication standards

Qualification of welding procedures, welders and welding operators are in accordance with section IX of the ASME Boiler and Pressure Vessel Code or BS 4870: Part 1 and BS 4871: Part 1, DIN 8560 or EN-288-3.

All welds are visually examined and assessed in accordance with ASME B31.3 or relevant code.

Dimensional standards

- Flanged cast steel fittings are in accordance with ANSI B16.5 Class 150.
- Flanged ductile Iron fittings are in accordance with ANSI B16.42 Class 150.

- Fabricated fittings are in accordance with the dimensions shown in the following Tables.
- Pipe diameters and wall thicknesses are in accordance with the dimensions in the following tables.
- Flanges for pipe and fittings are in accordance with ANSI B16.5 Class 150.
- Flanges are slip on welding, socket welding or welding neck types.
- Loose backing flanges are suitable for use with welding collars.
- All relevant dimensions and tolerances are in accordance with ANSI B16.5 Class 150.
- Threaded bolt holes are not permitted except for reducing flanges. Threaded bolt holes in reducing flanges are UNC unless specified otherwise.
- Welding collars for use with loose backing flanges are slip on welding, socket welding or welding neck type.
- The diameters and thicknesses are given in the following dimension table.
- The dimension table lists the outside diameters. The outside diameter of the instrument Tee bodies are the same as the lined space. The lining on the faces of flanges have uniform thickness, not less than 80% of the actual wall thickness.
- The Pexgol lining thickness in the following table is the standard. Higher thicknesses are available on request.

Construction of flanged fittings

Completed fittings are one piece construction. Flanges are fixed. The preparation and assembly of welded branch connections are in accordance with BS 2633 or ASME B31.3.

Attachment of flanges and collars

Attachment of flanges and collars are done by both back fillet and bore welds.

Transition from the bore to the flanged face must incorporate a radius to prevent undue stressing of the liner.

Fabrication dimensional tolerances

Tolerances for flanges and fittings is in accordance with the relevant standards.

Fabricated pipework are in accordance with the following tolerances:

Squareness of flanges – Square to the axis of the pipe or fitting to within 0.05 mm per 25 mm measured across the face.

- Flange faces – Faces should not be uneven or

concave. Convexity from the bore to the periphery must not exceed 0.4 mm per 25 mm width of face.

- Flange drilling – PCD +/- 1.5 mm. c/c of bolt holes +/- 0.8mm. Eccentricity between PCD and RFD up to 2-½" +/- 0.8 mm, 3" and greater +/- 1.5 mm.
- Bolt holes – Bolt holes are off centre and equally spaced about the centre line to an accuracy of 1.5 mm.
- Linear and angular dimensions – Linear dimensions +/- 1.5 mm; angular dimensions +/- 0.25 degrees.

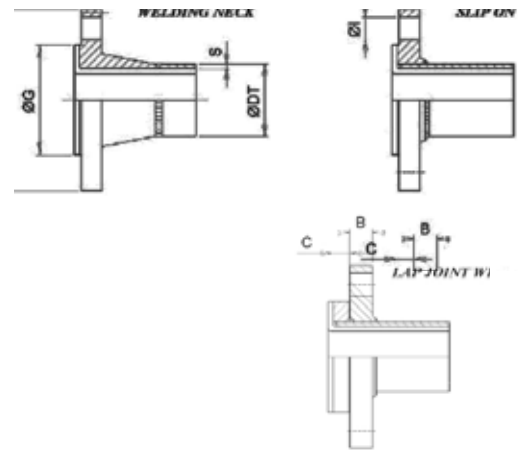

Table 112.1: Dimension Table

Nom	DT	D	G	I	B	C	S	Pex Lining thick.
Size	mm	mm	mm	n x i	mm	mm	mm	mm
1"	33.5	108	50.8	4 x 15.7	14.2	12	3.38	3.0
1 ¼"	42.2	117.3	63.5	4 x 15.7	15.7	12	3.56	3.0
1 ½"	48.3	127	73.2	4 x 19.1	17.5	12	3.68	3.0
2"	60.5	152.4	91.9	4 x 19.1	19.1	14	3.91	3.5
2 ½"	73.2	177.85	104.6	4 x 19.1	22.4	14	5.16	3.5
3"	88.9	190.5	127.0	4 x 19.1	23.9	16	5.49	4.0
3 ½"	101.6	215.9	139.7	8 x 19.1	23.9	16	5.74	4.0
4"	114.3	228.6	157.2	8 x 22.4	23.9	16	6.02	4.5
5"	141.3	254	185.7	8 x 22.4	23.9	18	6.55	4.5
6"	168.4	279.4	215.9	8 x 22.4	25.4	18	7.11	6.0
8"	219.2	342.9	269.7	8 x 22.4	28.4	20	8.18	6.0
10"	273.1	406.4	323.9	12 x 25.4	30.2	22	9.27	6.0
12"	323.9	482.6	381.0	12 x 25.4	31.8	22	9.53	7.0
14"	355.6	533.4	412.8	12 x 25.4	35.1	25	9.53	7.0
16"	406.4	596.9	469.9	12 x 28.4	36.6	25	9.53	7.0
18"	457.2	635	533.4	16 x 31.8	39.6	25	9.53	7.0
20"	508	698.5	584.2	20 x 31.8	42.9	25	9.53	7.0
24"	609.6	812.8	269.2	20 x 35.1	47.8	25	9.53	7.0

Internal finish of housings

The interior surfaces and flange faces are clean and free of sharp corners, burrs, rust, scale, weld spatter or other protrusions that could adversely affect the lining.

Lining

The method of lining and the fit of the lining ensures that the lining is capable of withstanding the temperature, pressure and vacuum ratings of the system.

All interference fit linings in straight pipes are normalised prior to flaring.

Completed linings show no evidence of pinholes, porosity, cracks or bad workmanship. Sealing surfaces are free of surface defects that could impair sealing effectiveness. Scratches, dents, nicks or tool marks on the sealing face are not deeper than 0.15 mm.

Any of these defect types less than 0.15mm but extending across the face cause the product to be rejected.

Blind flanges have linings firmly attached linings.

Production testing

For each batch, at least one representative sample of each nominal size of fittings is selected; tests are carried out to determine mechanical properties and SG.

Where samples do not comply with the requirements stated in this specification, each tube in the batch must have samples cut from each end and the samples are subjected to the same tests.

Any sample not meeting the specified requirements leads to rejection of the whole tube.

The outside diameter and wall thickness are measured. Tubes not complying with the standard are rejected.

Cracks found at the ends of tubes are cut off along with at least 50mm of adjacent material.

When specified, each liner tube is subjected to a flattening

test. Each length of tube is passed through a pre-set gap between two powered rollers. The gap is set at 50% of the outside diameter of the tube. The tube is rotated about the longitudinal axis through 90° and then passed back through the roller gap.

The tube is examined for cracks. A crack, if found, is cut out along with at least 50mm of adjacent material.

Hydrostatic pressure test

Hydrostatic pressure test is carried out at 16 Bar water in air. Any evidence of leakage are cause for rejection.

Electrostatic test

Electrostatic testing is carried out at a minimum voltage of 20,000V. The full surface of every lining is tested. Any pinholes are cause for rejection.

Final Examination

Each item is examined visually. Following satisfactory completion, the outside edge of the flange is stamped with a letter "I" to indicate compliance.

External finish

The outside surface of all pipe and fittings are finished as follows.

Shot blast SA 2-½ and coated with one coat zinc phosphate, zinc epoxy or zinc silicate primer. After painting, blocked bolt holes and vents are cleared.

Marking and identification: The following information is marked permanently on each fitting by casting into the body or by hard stamping the flange edge in letters at least 6 mm high:

- Manufacturer's marking
- Lining material

Packaging

All flanges are fitted with protective covers. These covers

Table 113.1: Pressure/Temperature Rating

Temperature °C	Pressure			
	ANSI # 150		ANSI # 300	
	PSI	BAR	PSI	BAR
20	250	17.2	450	31.0
50	244	17	425	29.3
100	235	16	390	26.9

The pressure ratings for ANSI 150# and PN16 dimensioned fittings are based on ratings in ANSI B 16.5.

The pressure ratings for ANSI 300# dimensioned fittings are based on the rating in ANSI B 16.5 300#, down rated to compensate for the decrease in mechanical properties at elevated temperatures of the lining materials.

are removed just prior to installation. Fittings are fitted with medium density fibreboard blanks or alternatively snap-on proprietary plastic blanks could be used.

Performance

All lined fittings meet the temperature, pressure, and vacuum ratings stated in the Lined Fittings manual.

Service limitations

For positive and negative pressure limitations versus temperature, see table next page.

Service temperature limits, subject to compatibility with the fluid being handled are:

PE-X: -50° to +115°C

When lined fittings are exposed to very low temperatures (below -50°C) consideration must be given as to the suitability of the material used for the housings. See section below for further information.

Notes

- Lined pipes and fittings made with PE-X inner coating can be manufactured in diameters from 2" and up to 24".
- Lined pipes and fittings made with Teflon inner coating can be manufactured in diameters from 1" and up to 24".
- For lined pipes or fittings in lower/higher diameters please consult with Golan.

Table 114.1: Vacuum/Temperature Rating

Liner	Temperature °C	Diameter											
		25	40	50	80	100	150	200	250	300	350	400	
PE-X	20	Full	Full	Full	Full	Full	Full	Full	Full	Full	Full	Full	Full
	50	Full	Full	Full	Full	Full	Full	Full	-	-	-	-	
	80	Full	Full	Full	Full	Full	Full	-	-	-	-	-	

System design and supports

Pipe systems must be adequately supported to avoid excessive deflection of flanged joints, and supports should be installed close to flanges. The requirement for adequate support is critical in areas of high levels of concentration of valves and fittings.

Butterfly valves are usually designed for straight metallic or thermoplastic systems, with the diameter of the vane being defined as a function of the inner diameter of the pipe system under consideration. The inner diameter of lined steel pipe is considerably smaller than the actual steel pipe. Inner diameters of thermoplastic pipes tend to be considerably smaller due to their heavy wall thickness. Consequently, some interference between the inner liner of a lined pipe and the valve vane might be experienced. The designer should consider this possibility early in the selection process for pipe systems and valves, and if required, incorporate adequate conical spacers between the flanges of plastic fittings and the valve.

Installation and maintenance instructions for lined fittings

Lined products must not be welded, brazed or torch cut to prevent damaging the lining.

Handle the material with due care and attention, avoiding all mechanical shocks.

All flanges are covered to protect them from damage during shipment, storage and handling onsite. If covers are removed for inspection purposes prior to installation, replace them immediately after inspection of each item is completed.

When joining a Pexgol pipe and lined fittings together, the use of gaskets between the sealing faces is usually not necessary.

Under normal conditions, remove covers only immediately prior to installation. As gaskets are often not required, utmost attention is required to avoid scratching or otherwise damaging the lining on flange faces.

In case of leakage, inspect the sealing faces of each component for grooves or chips. Grooves or nicks not deeper than approximately 15% of the flare thickness can be removed with a fine-grade abrasive paper.

Brass Fittings for Pexgol Pipes Class 15 & 24

Notes:

- It is recommended to install brass fittings above the ground.
- If you must install them, make sure they are protected from corrosion.
- Do not connect brass fittings to steel or galvanised steel pipes or fittings-
- All thread outlets are BSPT.
- NTP threads are available upon request.

Branch-off saddles: male & female thread
range 32 - 160 mm



GP bolt connectors: brass male BSPT
thread range 32 - 160 mm



Hela 8010 Pex double bolt connectors
brass class 15/24 range 32 - 160 mm



HELA 8045 Pex equal Tee bolt connectors
brass class 24 range 40 - 63 mm



HELA 8047 reducing Tee bolt connectors
brass class 24 range 25 - 50 mm



Various brass elbows, Tees, nipples and
bushings in sizes of up to 4"



For full details, see Pexgol Fittings Catalogue pages 117 to 146.

Branch-Off Saddles

Branch-off saddles are designed for side outlets of a maximum diameter equaling half of the main pipe's diameter. They are made from plastic or metal. Plastics saddles may be installed below ground. If you must install metal saddles below ground, make sure the ground is not corrosive for brass or stainless steel saddles. Do not connect brass fittings to steel or galvanized steel pipes or fittings. Pexgol pipes can be used with plastic saddles such as Plasson mechanical saddles or electrofusion saddles, with restrictions regarding the allowable temperature and pressure range, according to Golan's recommendations for Pexgol pipe connections. Golan's metal saddles are suitable for the full temperature and pressure ranges of Pexgol pipes. Brass saddles with threaded outlets are used for pipes from 32 mm to 160 mm diameter; see the next page for the installation of

saddles. For diameters bigger than 110 mm, stainless steel saddles with threaded or flanged outlets (according to standard requirements) are available. All metal saddles are suitable for pipes transporting drinking water. Saddles with internal rubber lining at the flange outlet are available for corrosive materials that might damage the stainless steel saddles. Golan supplies these saddles on special request.

Branch-off saddles - male & female
thread range 32 - 160 mm *



Pexgol stainless steel branch-off saddles
threaded outlet *



Branch saddles 63 - 710 mm **



* For full details, see Pexgol Fittings Catalogue.

** For full details, see Plasson, Friatec and GF/Wavin catalogues.

PE-Xa Pexgol Elbows

Material

Body: Cross Linked Polyethylene (PE-Xa)

Specifications

Temperature range: -50°C / -58°F to 110°C / 230°F

Notes

- The elbows are supplied with clamps and fixing elements in order to be able to supply an accurate angle. In addition this fixing elements allow for minor correction of the angle in the field if this is necessary.
- After installation it is possible to remove the clamps if required.

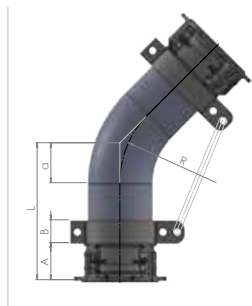

Standard Pexgol 45° and 90° (1.5D and 3D) elbows are produced from Pexgol pipes of class 15 to 30 according to a proprietary process.

Pexgol elbows are supplied in standard lengths according to the tables in the catalogue.

Pexgol elbows can be supplied with the following end versions:

- Flared-ends & Slip on flanges
- Plain ends for Electrofusion Couplers
- Fitted with Flange couplers
- Combination of the above mentioned end versions. To -2 degrees and length tolerance of +/-25 mm.

For full details see "Fittings Catalogue" where the full range of products is available. When ordering, please specify pipe ends.

Table 117.1: Dimensions of Pexgol elbows with GP flange couplers

Outside Diameter (mm)	1.5D		3D	
	45 °	90 °	45 °	90 °
	L [mm]	L [mm]	L [mm]	L [mm]
50	190	260	210	320
63	200	280	180	380
75	230	320	220	440
90	260	380	260	510
110	310	450	310	620
125	320	490	330	680
140	350	530	370	750
160	370	580	400	830
180	390	630	430	920
200	430	700	480	1010
225	480	780	520	1130
250	530	860	580	1260
280	570	940	640	1390
315	630	1040	720	1550
355	720	1190	810	1750
400	780	1310	900	1950
450	850	1440	1010	2170
500	960	1620	1140	2420
630	1080	1910	1360	2800
710	1210	2140	1530	-

The dimensions from the table are relevant only if the GP Flange Coupler are assembled in Golan, if this not the case, the dimensions in the Plain Ends table must be considered. Temperature de-rating according to the table in page 9

Table 118.1: Dimensions of Pexgol elbows with flared-ends

Pexgol Pipe O.D. (mm)	1.5D		3D	
	45 ° L [mm]	90 ° L [mm]	45 ° L [mm]	90 ° L [mm]
50	460	520	450	560
63	480	560	470	620
75	490	590	500	670
90	510	630	530	740
110	550	690	580	830
125	570	730	600	890
140	590	770	630	960
160	610	820	670	1040
180	640	880	710	1130
200	670	930	760	1220
225	700	1000	800	1330
250	730	1060	850	1430
280	760	1130	900	1550
315	800	1210	970	1700
355	870	1340	1060	1890
400	920	1450	1140	2070
450	980	1570	1240	2280
500	1030	1690	1330	2490

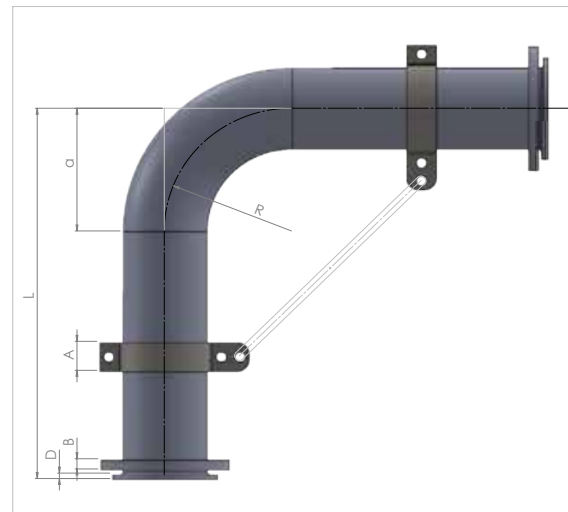
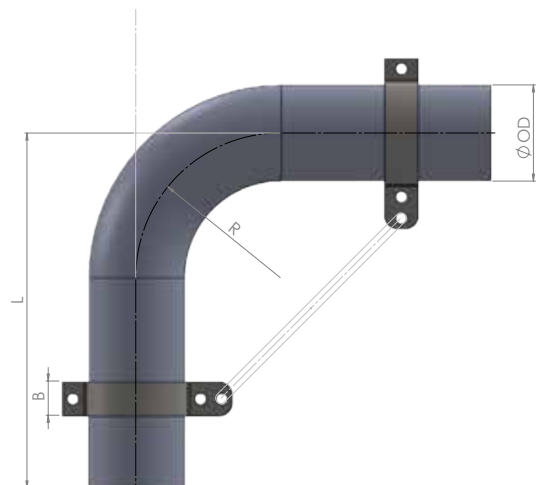

Table 118.2: Dimensions of Pexgol elbows with plain-ends

Pexgol Pipe O.D. (mm)	1.5D		3D	
	45 ° L [mm]	90 ° L [mm]	45 ° L [mm]	90 ° L [mm]
50	230	290	240	360
63	250	330	270	420
75	270	360	300	470
90	300	410	340	540
110	330	480	390	640
125	360	520	420	710
140	380	560	450	770
160	400	610	480	860
180	440	680	540	960
200	470	730	580	1050
225	530	830	660	1180
250	560	890	700	1280
280	600	970	760	1410
315	640	1060	830	1560
355	700	1170	910	1740
400	820	1350	1050	1980
450	880	1470	1150	2190
500	950	1600	1250	2410
630	1120	1940	1510	2800
710	1230	2160	1670	-



PE-Xa Flared End Connectors

Material

Body: Cross Linked Polyethylene (PE-Xa)

Specifications

Temperature range: -50°C / -58°F to 110°C / 230°F

The ends of the Pexgol pipe are heated and then flared by a proprietary process, performed at Golan Plastic Products. The final pipe end is similar to a stub end. Flared ends can be also be made at the ends of Pexgol elbows, reducers, etc.

The loose flange is usually mounted over the pipe at Golan during the flaring process. Alternatively, split flanges can be supplied and mounted later. The flanges are available according to table No. 112.1 "Compatibility of Pexgol Flanges" that conform to different standards are available by special request. Detailed drawings of flanges are supplied on request. Plastic coated flanges are available on request. Pexgol flared end pipes are available in lengths according to customer specifications. They are also available in lengths of 5.80 m to fit into 20 ft containers or in lengths of 11.80 m to fit into 40 ft containers. The elbows with flared ends are available from our catalog according to specified length. Pexgol flared end pipes are available in minimum lengths according to Table 109.1.

The straight sections with flared ends are produced with a tolerance of +/- 10 mm in length. The elbows with flared ends are produced with a tolerance of up to +5 degrees and +/- 10 mm in length

The catalogue number in Table 109.1 represents a Pexgol stub-end that is a Pexgol pipe class 15 spool with a standard length of 500 mm and with a flared end on one side. For example:

FLA16014.6 means pipe section 160 mm, wall thickness 14.6 mm, and length 500 mm

For sections shorter than 500 mm, use the length L in the table.

If a different wall thickness is required or a longer section is required, or flared end on both sides, or the section

should be supplied with loose flanges, please specify according to the following example:

For a pipe section 160 mm, wall thickness 14.6 mm, length 2500 mm with one flared end & flange – FLA16014.6 2500 mm with flaring and flange ASA 150 on one side.

Please refer to our Fittings Catalogue where the full range of fittings is available.

Table 119.1: Length (L) for Pexgol stub end

Catalogue Number	Pipe Diameter (mm)	Standard Length (mm)	Minimum Length L (mm)
FLA322.9	32	500	85
FLA403.7	40	500	85
FLA6504.6	50	500	104
FLA635.8	63	500	120
FLA756.8	75	500	130
FLA908.2	90	500	140
FLA11010	110	500	160
FLA12511.4	125	500	182
FLA14012.7	140	500	180
FLA16014.6	160	500	180
FLA18016.3	180	500	198
FLA20018.1	200	500	200
FLA22520.4	225	500	200
FLA25022.7	250	500	215
FLA28025.4	280	500	228
FLA31528.6	315	500	238
FLA35532.2	355	500	255
FLA40036.3	400	500	285
FLA45040.9	450	500	320
FLA50045.4	500	500	350
FLA56050.8	560*	500	380
FLA63057.2	630*	500	400
FLA71064.5	710*	500	450



(*)For stub ends above OD 500 mm contact Pexgol Team.

Bolts for connecting two flanged couplings with flared ends

Pexgol Pipe Diameter	Flange Size	Bolt Size*	Bolt Length (mm)	No. of Bolts	Torque N x m	Torque lb x ft
63	2"	5/8"	50	4	98	72
75	2 ½"	5/8"	50	4	98	72
90	3"	5/8"	50	4	98	72
110	4"	5/8"	50	8	98	72
125	4"	5/8"	50	8	98	72
140	6"	3/4"	60	8	163	120
160	6"	3/4"	60	8	163	120
180	6"	3/4"	60	8	163	120
200	8"	3/4"	60	8	163	120
225	8"	3/4"	60	8	163	120
250	10"	7/8"	70	12	260	192
280	10"	7/8"	70	12	260	192
315	12"	7/8"	70	12	260	192
355	14"	1"	70	12	399	294
400	16"	1"	75	16	399	294
450	18"	1-1/8"	75	16	578	426
500	20"	1-1/8"	100	20	578	426

Notes:

- Torquening the bolts should be done in a crisscross manner.
- When connecting a GP Flanged Coupler with a flared end, the torquening values of the GP Flanged Coupler are the ones that should be use.

Compatibility of Pexgol Flanges

Table 76.1 describes the compatibility of each flange. Useful dimensions are also presented in the table. The flanges were designed to be compatible with most existing flange standards. Therefore, most of the bolt holes are oval and slightly oversized.

Complete drawing of flanges according to any required standard are prepared on request. Flanges according to other flange standards can be supplied by special order. Split flanges of all flange standards are supplied by special order.

Table 121.1: Compatibility of Pexgol flanges

Catalogue Number	Pipe Diameter	ISOR 2084 B.S. 4504		ANSI B 16.5 ASA 150	AS 2129 B.S. 10:1962		Wall Thickness	No. of Bolts	Outside Diameter (mm)	Weight (kg)
		DIN 2632	DIN 2633		Table D	Table E				
		ISO PN 10	ISO PN 16		PN 10	PN 16				
65003201	32	DN25	DN25	1"	DN25-1"	DN25-1"	14	4	108	0.9
65004012	40	DN32	DN32	1.25"	DN32-1.25"	DN32-1.25"	16	4	118	1.2
65005015	50	DN40	DN40	1.5"	DN40-1.5"	DN40-1.5"	17	4	150	2.0
65006302	63	DN50	DN50	2"	DN50-2"	DN50-2"	19	4	152	2.2
65007525	75	DN65	DN65	2.5"	DN65-2.5"	DN65-2.5"	22	4	178	3.4
65009003	90	DN80	DN80	3"	DN80-3"	DN80-3"	24	4	190	4.0
65011004	110	DN100	DN100	4"	DN100-4"	DN100-4"	24	8	228	5.7
65012504	125	DN100	DN100	4"	DN100-4"	DN100-4"	24	8	228	5.1
65014006	140	DN150	DN150	6"	DN150-6"	DN150-6"	25	8	279	8.7
65016006	160	DN150	DN150	6"	DN150-6"	DN150-6"	25	8	279	7.6
65018006	180	DN150	DN150	6"	DN150-6"	DN150-6"	25	8	279	6.6
65020008	200	DN200	X	8"	DN200-8"	DN200-8"	28	8	343	12.6
65022508	225	DN200	X	8"	DN200-8"	DN200-8"	28	8	343	10.6
64825010	250	DN250	DN250	10"	X	DN250-10"	30	12	406	17.8
64925010	250	X	X	X	DN250-10"	X	22	8	406	13.0
64828010	280	DN250	DN250	10"	X	DN250-10"	30	12	406	14.5
64928010	280	X	X	X	DN250-10"	X	22	8	406	10.6
65031512	315	DN300	DN300	12"	DN300-12"	DN300-12"	32	12	482	24.1
65035514	355	DN350	DN350	14"	DN350-14"	DN350-14"	35	12	533	31.4
64840016	400	DN400	DN400	16"	X	X	36	16	597	40.2
64940016	400	X	X	X	DN400-16"	DN400-16"	36	12	578	35.3
64845018	450	X	X	18"	X	DN450-18"	40	16	635	45.3
64945018	450	X	X	X	DN450-18"	X	40	12	641	47.2
64850020	500	DN500	DN500	20"	X	X	43	20	698	57.6
64950020	500	X	X	X	DN500-20"	DN500-20"	43	16	705	60.2
64863024	630	X	DN600	24"	X	X	48	20	813	69.3
64963024	630	X	X	X	DN600-24"	DN600-24"	48	16	825	75.1

PE-Xa Short Sections with two Flared Ends

The following table lists the lengths of short flared ends Pexgol sections.

The A length is relevant for short sections which are supplied with regular flanges.

The shorter B length is applicable for short sections which are supplied with split flanges that can be mounted after the short section is flared.

The short sections with flared ends are produced with a tolerance of +/- 10 mm in length.

Table 122.1: Dimensions of PE-Xa short sections

Pipe Outside Diameter (mm)	Minimum length of a flanged Pexgol pipe with full S.O. flanges	Minimum length of a Pexgol pipe with split S.O. flange
	A (mm)	B (mm)
90	210	165
110	215	165
160	225	175
180	240	200
200	290	230
225	290	230
250	355	290
280	340	280
315	380	320
355	355	285
400	395	320
450	410	330
500	550	350

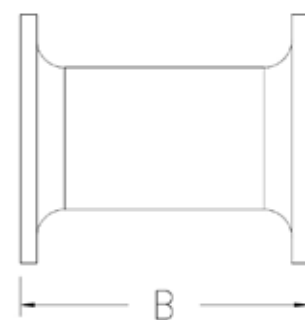
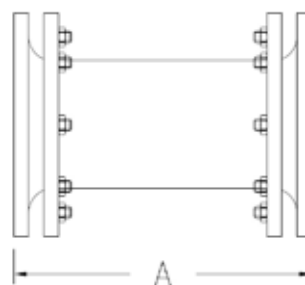

PE-Xa Spigot Reducers

Material

Body: Cross Linked Polyethylene (PE-Xa)

Specifications

Temperature range: -50°C / -58°F to 110°C / 230°F

Pexgol concentric spigot reducers are available according to the following table. Other sizes are available by special order. The working pressures and temperatures of the Pexgol spigot reducers are the same as for the d1 side of the reducer. The table "Dimensions of Pexgol spigot reducers" lists the dimensions of standard spigot reducers. The sizes in the table are a partial list only, and other sizes are available on request.

When using the Spigot reducers to connect them with electrofusion couplers, the end user can shorten lengths L1 or L2.

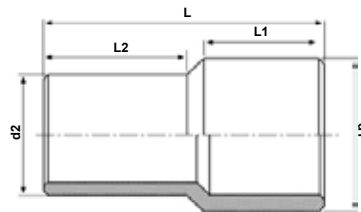

Table 124.1: Dimensions of standard Pexgol spigot reducers

Catalogue Number	Size d1 x d2 (mm)	Size L (mm)	Size L1 (mm)	Size L2 (mm)	Weight (kg) Class 10	Weight (kg) Class 15	Weight (kg) Class 24
RED75x63	75x63	405	205	175	0.20	0.3	0.43
RED90x75	90x75	420	215	180	0.34	0.49	0.7
RED90x63	90x63	420	215	175	0.35	0.49	0.71
RED110x90	110x90	580	280	270	0.55	0.79	1.14
RED110x75	110x75	580	280	255	0.56	0.8	1.16
RED110x63	110x63	580	280	240	0.57	0.81	1.17
RED125x110	125x110	620	280	280	0.73	1.04	1.48
RED125x90	125x90	620	280	270	0.78	1.12	1.59
RED140x125	140x125	700	360	290	0.98	1.38	1.98
RED140x110	140x110	700	360	280	1	1.41	2.03
RED160x140	160x140	720	355	360	1.32	1.88	2.68
RED160x125	160x125	720	355	350	1.4	2	2.85
RED160x110	160x110	720	355	340	1.43	2.04	2.9
RED180x160	180x160	580	260	255	2.1	3	4.2
RED180x140	180x140	580	260	245	1.5	2.2	3.1
RED180x125	180x125	580	260	235	1.6	2.3	3.3
RED200x160	200x160	580	260	255	2.45	3.46	4.97
RED225x200	225x200	590	250	270	3.23	4.6	6.58
RED225x180	225x180	590	260	260	3.1	4.35	6.2
RED225x160	225x160	590	260	260	3.45	4.92	7.03
RED250x225	250x225	680	330	320	4.25	6.02	8.74
RED250x200	250x200	680	330	320	4.41	6.24	9.07
RED280x250	280x250	700	340	330	5.72	8.15	15.57
RED280x225	280x225	700	300	320	5.98	8.51	16.26
RED315x280	315x280	770	340	330	7.82	11.14	18.87
RED315x250	315x250	770	340	330	8.13	11.58	19.62
RED355x315	355x315	795	350	340	10.7	15.25	23
RED355x280	355x280	795	350	340	11.31	16.12	24.3

Table 124.2: Dimensions of non-standard Pexgol spigot reducers (manufactured by special request)

Catalogue Number	Size d1 x d2 (mm)	Size L (mm)	Size L1 (mm)	Size L2 (mm)	Weight (kg) Class 10	Weight (kg) Class 15	Weight (kg) Class 24
N/A	400x355	815	355	350	15.02	21.44	28.58
N/A	400x315	815	355	350	15.72	22.43	29.91
N/A	450x400	865	275	355	21.1	30.17	36.76
N/A	450x355	865	400	355	21.96	31.4	38.26
N/A	500x450	631	302	275	28.4	40.7	43.22
N/A	500x400	659	302	249	29.66	42.51	45.14
N/A	630x500	782	340	302	55.94	79.49	67.52
N/A	630x450	809	340	275	57.87	82.24	69.85

Pexgol Reducers with Flared Ends and Flanges

The working pressures and temperatures of the Pexgol spigot reducers are the same as for the d1 side of the reducer. Pexgol reducers are supplied with flared ends, with or without flanges. If supplied without flanges, use split flanges that can be installed later by the end user.

The maximum length of each flared end is specified as L1 or L2 according to table "Length (L) for Pexgol stub end" or any length down to the minimum length L in table "Dimensions of Pexgol spigot reducers"

The reducers with flared ends are produced with a tolerance of +/- 10 mm.



PE-Xc ID Adaptor/Spacer

Golan supplies special reducers for individual projects. For example:

- Reducers to match the inside diameter of Pexgol pipes to steel pipes or pipes made from other materials.
- Adaptors for Pexgol pipes with the same ID but different OD.

To order the Pexgol special reducers/adaptors, please consult Golan's application engineers.

Spacers which are installed between Pexgol pipes and butterfly valves to allow the opening of the valve.

Material

Body: Cross Linked Polyethylene (PE-Xc)

Specifications

- **Temperature range:** -30°C / -22°F to 90°C / 194°F
- Available for flange size 3" to 20"
- Supplied in width 35 mm - 80 mm



Catalogue Number 65900040

Pexgol Instrument Tees & Water Flushing Ports

Pexgol Instrument tees & Water flushing ports for all Pexgol pipe sizes are available. They are installed between two adjacent flanges. The inlet is made of 316 stainless steel. Other corrosive resistant materials can be specified on request. The inlet is available as $\frac{3}{4}$ " or $\frac{1}{2}$ " female thread or 1", $\frac{3}{4}$ " or $\frac{1}{2}$ " male thread. To order Pexgol special reducers/adaptors, please consult Golan's application engineer.

Pexgol Single/Double Sided Orifice

Golan supplies this accessory according to the client design with one or two connecting points.

Catalogue Number 65900045



Pexgol Transition Flange

When designing Pexgol there are cases where transition flanges are required in order to allow connections between different flange sizes or between different flange standards. Comes with a special internal PE-X part which comes in contact with the abrasive/corrosive liquid. The PE-X insert will act as a barrier between the liquid and the flange, allowing a continuous full PE-X protective solution.

Standard transition flange sizes are normally supplied between 3" – 20". For smaller/bigger flange sizes please consult or to add an ID adapter inside the same transition flange please consult with us.

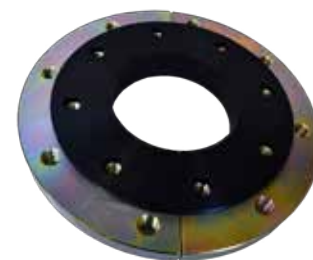

Flanged Couplers for Pexgol Pipes

Material

Body: Hot Galvanized Spheroidal Cast Iron GGG40 (ASTM A-536). The inner surface of the coupling has special stainless steel teeth

Gasket: EPDM rubber

Bolts: Galvanized carbon steel

Specifications

Pressure & Temperature rating: Suitable for the full pressure and temperature range of Pexgol pipes from class 10 to class 30.

Available in sizes from diameter 63 mm to 710 mm.

The couplers can be used for the full range of temperatures and pressures, the same as Pexgol pipes. Pexgol flange couplers consist of either two halves or four quarters depending on the pipe size. The body of the coupler is made of Spheroidal cast iron GGG40 (ASTM A-536). The inner surface of the coupler has special stainless steel teeth.

These teeth penetrate into the pipe wall during tightening of the coupler and provide good anchoring onto the pipe, preventing the pipe from pulling out from the fitting. The flange couplers are supplied with an integral gasket and bolts for connecting the two halves or four quarters.

The gasket seals between the coupler and the pipe, and also between the coupler and the opposite flange.

The gasket is designed so that the coupler does not come into contact with the liquid flowing through the pipe.

The standard gasket is made of EPDM; other materials such as Viton and HNBR can be supplied according to special request. The flange has oval holes designed to fit most international standards; see table 116.1: "General dimensions of flange couplers and bolts for connecting two quarters of coupler".

Installing the coupler is simple and easy:

- Place the gasket on the pipe.
- Open the screws and apply anti seize lube.
- Place the coupler around the pipe and tighten the screws equally. Recommended: use of electric rattle guns
- For connecting two flange couplers use table "General dimensions of flange couplers and bolts for connecting two quarters of coupler" if needed.

Note: A complete installation manual is available upon request.



Table 128.1: Compatibility with international flange standards

Catalogue Number	Pipe OD (mm)	Nominal Size Flange		DIN			ANSI		BSTD
		DN (mm)	Inches	2632	2633	2634	125	150	
				10	16	25			
50806320	63	50	2"	V	V	V	V	V	-
50807525*	75	65	2 1/2"	V	V	-	V	V	-
50809030	90	80	3"	V	V	V	V	V	-
50811040	110	100	4"	V	V	V	V	V	-
50812540	125	100	4"	V	V	V	V	V	-
50814060	140	150	6"	V	V	-	V	V	V
50816060	160	150	6"	V	V	-	V	V	-
50818060	180	150	6"	V	V	-	V	V	-
50820080	200	200	8"	V	-	-	V	V	V
50822580	225	200	8"	-	-	-	V	V	V
50825010	250	250	10"	V	V	-	V	V	-
50928010	280 ASA	-	10"	-	V	-	V	V	-
50828010	280 BS	250	-	-	-	-	-	-	V
50831512	315	300	12"	-	V	-	V	V	V
50835514	355	350	14"	-	-	-	V	V	V
50840016	400	400	16"	-	-	-	V	V	-
50845018	450	450	18"	-	-	-	V	V	-
50850020	500	500	20"	V	V	-	V	V	-
50863024	630	-	24"	-	-	-	V	V	-
50871028	710	-	28"	-	-	-	V	V	-

(* Only available by special request.

Table 129.1: "General dimensions of flange couplers and bolts for connecting two quarters of coupler".

Catalogue Number	Pipe Outside Diameter (mm)	Nominal Flange Size		A	C	Bolt size (inches)	Bolt length (mm)	No. of Bolts	Weight (kg)
		DN	Inches						
50806320	63	50	2	165	70	$\frac{3}{8}$ "	40	4	2,7
50807525	75	65	2 $\frac{1}{2}$ "	185	80	$\frac{1}{2}$ "	45	4	2,5
50809030	90	80	3	208	96	$\frac{1}{2}$ "	45	4	4
50811040	110	100	4	242	110	$\frac{5}{8}$ "	45	8	6,5
50812540	125	100	4	242	110	$\frac{5}{8}$ "	45	8	8
50814060	140	150	6	285	120	$\frac{5}{8}$ "	50	8	10
50816060	160	150	6	285	120	$\frac{5}{8}$ "	50	8	11,2
50818006	180	150	6	241	119	$\frac{5}{8}$ "	50	8	12,1
50820080	200	200	8	348	130	$\frac{5}{8}$ "	50	8	13
50822580	225	200	8	344	130	$\frac{5}{8}$ "	50	8	12,4
50825010	250	250	10	410	150	$\frac{5}{8}$ "	60	8	17
50828010	280 ASA		10	405	160	$\frac{5}{8}$ "	60	8	20
50928010	280 BS	250		405	160	$\frac{5}{8}$ "	60	8	20
50831512	315	300	12	475	180	$\frac{3}{4}$ "	70	8	27,7
50835514	355	350	14	535	200	$\frac{3}{4}$ "	70	8	40
50840016	400	400	16	600	215	$\frac{3}{4}$ "	70	8	55
50845018	450	450	18	635	235	$\frac{3}{4}$ "	70	8	65
50850020	500	500	20	715	280	$\frac{3}{4}$ "	80	8	68
50863024	630	630	24	840	280	$\frac{3}{4}$ "	80	8	86

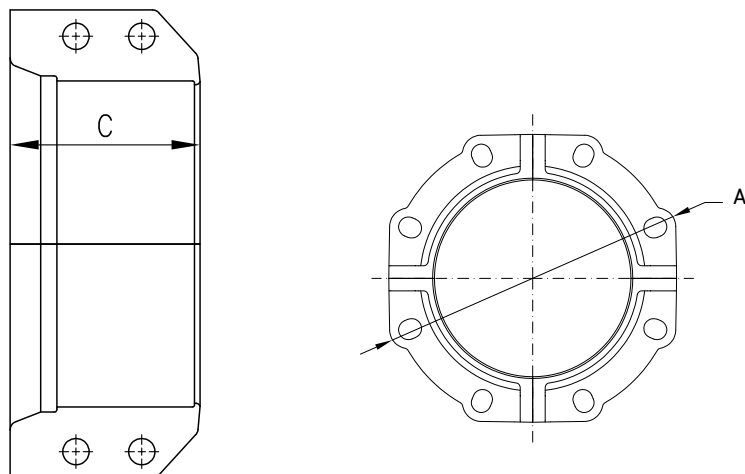

Table 130.1: Bolts for connecting two flanged couplings

Pexgol Pipe Diameter	Flange size	Bolt size**	Bolt length (mm)**	No.of bolts	Torque N x m	Torque lb x ft
63	2"	5/8"	50	4	81	60
75	2 ½"	5/8"	50	4	81	60
90	3"	5/8"	50	4	81	60
110	4"	5/8"	50	8	81	60
125	4"	5/8"	50	8	81	60
140	6"	3/4"	60	8	136	100
160	6"	3/4"	60	8	136	100
180	6"	3/4"	60	8	136	100
200	8"	3/4"	60	8	136	100
225	8"	3/4"	60	8	136	100
250	10"	7/8"	70	12	217	160
280	10"	7/8"	70	12	217	160
315	12"	7/8"	70	12	217	160
355	14"	1"	70	12	332	245
400	16"	1"	75	16	332	245
450	18"	1-1/8"	75	16	481	355
500	20"	1-1/8"	100	20	481	355
560	22"	1-1/4"	100	20	580	427
630	24"	1-1/4"	110	20	678	500
710	28"	1-1/4"	110	28	776	572

Fixpoint clamps

Material

Body: Carbon Steel body with internal gripping teeth made of 316L stainless steel

Notes

- Primer coated.
- Stainless steel internal gripping teeth.
- Installation method: welded or bolted.
- The purpose of this accessory is to prevent pull-out of mechanical fittings.

The fixpoint clamp (FPC) is made of steel with internal gripping teeth made of 316L stainless steel. The FPC is painted with a base paint.

The lower part of the clamp can be welded to the construction bridge (before installing the pipe) or it can be connected by screws.

Affix natural pipe bends with fixpoint clamps before and after each elbow. For pipe diameters of 280 mm and larger, support the natural pipe bends in the centre in addition to the two fix points noted.



Pexgol pipe behavior at high temperature

Pexgol pipes have a tendency to elongate considerably when exposed to sunlight due to a high thermal expansion coefficient which is typical for plastic pipes.

With increasing temperatures, the apparent modulus of the pipe decreases so the developing stress is not high.

When placing Pexgol pipe over pipe bridges, the thermal expansion is reduced by the use of suitable fixtures so that the pipe will develop internal stresses which do not cause any damage. There is no need to use expansion joints to protect PE-Xa pipe and fittings

Pexgol pipe behaviour at low temperature

When the ambient temperature drops below 20°C, the tendency to axial contraction could create axial stresses in the pipe. These stresses are absorbed by the pipe without causing damage (stress relaxation). Minimum service temperature is -50°C.

Maximum force at the fixpoint clamps

Determining the maximum force at the fixpoint clamp:

Pipes in above-ground installations are subjected to temperature variations which induce axial thermal movements: contraction or elongation.

These axial thermal movements are partially balanced by external friction between the pipe and the construction.

If a pipe is restrained with fixpoints, they will tend to restrain these thermal movements. As a result, these fixpoints will be subjected to axial forces which are balanced by axial thermal stresses inside the pipe's wall.

The axial thermal stresses can be calculated by the following formula:

$\sigma = E \times A \times \Delta T$ where:

- *E is the relevant (short term or long term) Modulus of Elasticity*
- *A is the coefficient of Thermal expansion or contraction*
- *ΔT is the temperature difference*

The values of the Modulus of Elasticity and the values of the coefficient of thermal expansion or contraction are temperature dependent and so are the values of the axial thermal stresses.

The highest values of the thermal stresses occur during the relatively short stage of temperature changes and

Table 132.1: Dimension table of fixpoint clamps

Catalogue Number	Pipe Diameter (mm)	L (mm)	W (mm)
66206302	63	240	40
66207525	75	252	40
66209003	90	266	40
66211004	110	286	50
66212505	125	294	50
66214006	140	308	50
66216006	160	329	50
66218006	180	349	50
66220008	200	372	60
66222508	225	398	80
66225010	250	422	80
66228010	280	453	80
66231512	315	489	80
66235514	355	529	100
66240016	400	574	100
66245018	450	624	100
66250020	500	674	100
66256022	560	734	100
66263024	630	804	100
66271028	710	925	100

therefore they involve the short term Modulus of Elasticity. These initial short term thermal stresses in the pipe decrease with time due to stress relaxation.

These long term stresses are usually low and therefore they are of no concern for the Pexgol pipe itself.

However, the initial high forces are transmitted through the fixpoints to the metal construction and they can damage it. Since the axial forces in the fixpoints and the metal construction are equal to the axial thermal forces in the pipe, it is easier to calculate directly the axial thermal forces in the pipe.

The axial thermal forces in the pipe can be calculated by multiplying the thermal stresses by the pipe cross section. It is recommended to design the metal construction based on the maximum theoretical axial forces.

The values of maximum theoretical axial forces are calculated assuming that the friction forces between the pipe and the construction are negligible.

The worst case scenario is when the pipe is installed in a certain ambient temperature T1 and then the temperature is going down to a lower temperature T2.

As the temperature is going down, the tendency of the pipe to contract is balanced by tensile forces in the fixpoints. The following table "Dimension table of fixpoint clamps" presents the values of the initial Short term thermal stresses as a function of the design temperature.

Table 132.2: Initial short term thermal stresses vs design temperature

Design Temperature		Thermal stress [MPa]
Ti [C°]	Tf [C°]	
100	110	0.25
90	100	0.26
80	90	0.28
70	80	0.29
60	70	0.31
50	60	0.36
40	50	0.41
30	40	0.53
20	30	0.65
10	20	0.66
0	10	0.88
- 10	0	1.01
- 20	- 10	1.30
- 30	- 20	1.61
- 40	- 30	2.72
- 50	- 40	1.11

These values are valid for a temperature difference of 10°C.

The following calculation example illustrates the way to calculate the Axial forces in the fixpoints.

A Pexgol pipe OD 280 mm/Wall thickness 25.4 mm

SDR 11 was installed in an ambient temperature of 40 °C.

The design temperature in this case is 40 + 20 = 60°C

In winter the temperature drops down to -30°C.

The design temperature in this case is -30°C

The axial forces in the fixpoints are calculated by adding the values of the thermal stresses for the temperature range between + 60°C to -30°C, and then multiply them by

the cross section of the pipe.

The sum of the values of the thermal stresses from Table 132.2 is 7.72 MPa:

Sum of the values: 7.72

The cross section of the pipe can be easily calculated according to page 77.

Ti [C°]	Tf [C°]	Thermal Stress [MPa]
60	70	0.31
50	60	0.36
40	50	0.41
30	40	0.53
20	30	0.65
10	20	0.66
0	10	0.88
- 10	0	1.01
- 20	- 10	1.30
- 30	- 20	1.61

Side Deflection

Large side deflection might be expected in the event of a malfunction, but there is no risk of possible damage due to one pipe "leaning" on its neighbour or rubbing against it.

Guiding Clamps for Pexgol pipes

The Pexgol pipe's tendency to "snake" is reduced by putting bars on both sides of the pipe to limit sideward deflection. Alternatively conventional clamps (FPC) without the internal gripping teeth, is recommended, using guiding clamps (GC), which are. The pipe can freely slide through in the axial direction but not sideways.

Fixpoint Bridge

Pullout protection of end couplings and other fittings

To ensure the pull-out resistance of certain fittings, do not lay the pipe perfectly straight, but rather with some surplus length (slack). In case of short pipes (up to about 10 metres), or in case of installations on pipe bridges (where it might be difficult to leave slack in the pipe), there should be a pull-out protection device such as a fixpoint clamp before and after every fitting.

This applies to some of the fittings; depending on the application design guidelines. If the pipe is installed in an inclined or a vertical position (for example – in dewatering applications) and common fixpoint clamps cannot be used, the fitting should be protected by a floating fixpoint device such as a fixpoint bridge. See Table 119.1 and page 102.

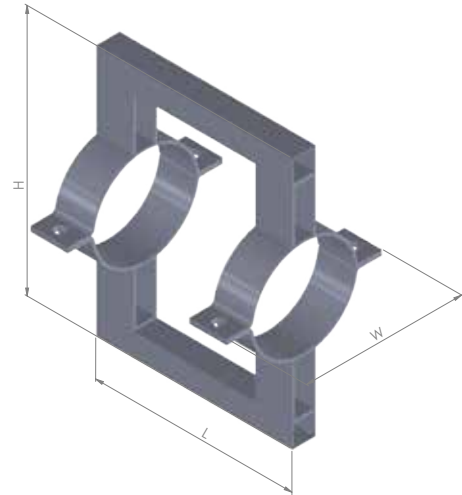

Table 134.1: Fixpoint bridge dimensions

Catalogue Number	NPS (inch)	L (mm)	H (mm)	W (mm)	Clamp Width (mm)	Bolt size
301063	63	260	290	231	40	1/2"
301075	75	270	300	242	40	1/2"
301090	90	320	350	257	40	1/2"
301110	110	360	380	278	50	5/8"
301125	125	360	380	294	50	5/8"
301140	140	380	480	308	50	5/8"
301160	160	380	480	330	50	5/8"
301180	180	400	480	350	50	3/4"
301200	200	420	480	372	60	3/4"
301225	225	460	500	398	80	3/4"
301250	250	510	560	423	80	3/4"
301280	280	520	560	453	80	3/4"
301315	315	580	650	490	80	3/4"
301355	355	650	700	530	100	1"
301400	400	750	750	574	100	1"
301450	450	750	800	624	100	1"
301500	500	800	850	674	100	1"
301560	560	800	900	734	100	1"
301630	630	800	950	804	100	1"



Fittings Catalogue





Index

- Flared Ends/Stub Ends
- Loose Flanges
- Pexgol Elbow
- Pexgol Reducer
- Flange Coupler
- Hydrant Connector
- Branch-Off Saddles - Flanged Outlet
- Branch-off Saddles - Female
- Flanged Outlet
- Brass Fittings
- GP Bolt Connector Stainless Steel
- Fixpoint Clamps
- Fixpoint Bridge
- Lined Concentric Reducer
- Lined Eccentric Reducer
- Lined Elbows
- Lined Equal Cross
- Lined Equal Tee
- Lined Instrument Tee
- Lined Lateral Tee
- Lined Reducing Tee
- Mechanical Double Connector

Flared Ends/Stub Ends

Standard Length (L) for Pexgol stub end

Catalogue Number	Pipe Diameter	Standard Length	Minimum Length L
FLA322.9	32	500	85
FLA403.7	40	500	85
FLA6504.6	50	500	104
FLA635.8	63	500	120
FLA756.8	75	500	130
FLA908.2	90	500	140
FLA11010	110	500	160
FLA12511.4	125	500	182
FLA14012.7	140	500	180
FLA16014.6	160	500	180
FLA18016.3	180	500	198
FLA20018.1	200	500	200
FLA22520.4	225	500	200
FLA25022.7	250	500	215
FLA28025.4	280	500	228
FLA31528.6	315	500	238
FLA35532.2	355	500	255
FLA40036.3	400	500	285
FLA45040.9	450	500	320
FLA50045.4	500	500	350



Loose Flanges

Material

Body: Galvanized Carbon Steel

Specifications

- The following table lists dimensions of flanges for Pexgol flared ends according to ANSI150 or BS 10 Table D.
- Flanges according to other flange standards are available by special order.
- Split flanges of all flange standards are also supplied by special order.



Flange BSTD



Flange ASA150

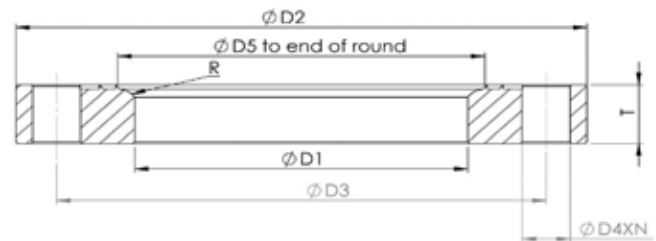

Catalogue Number	Pipe Diameter (mm)	Flange Diameter (inch)	Screw Circle Diameter (mm)	OD (mm)	Wall Thickness (mm)	Outer Radius (mm)	Radius (mm)	Inside Diameter (mm)	Bolt Hole Diameter (mm)	Amount of holes	Bolt Size	Weight (kg)
			D3	D2	T	D5	R	D1	D4			
64805015	50	1.5	98	127	17	62	6	52	16	4	5/8	1.4
64806302	63	2	118	152	19	77	7	65	22	4	5/8	2.3
64807525	75	2.5	140	178	22	91	8	78	19	4	5/8	3.5
64809003	90	3	150	190	24	106	8	93	22	4	5/8	4.1
64811004	110	4	190	228	24	130	10	116	19	8	5/8	5.8
64812504	125	4	216	254	24	145	10	131	23.5	8	3/4	7.1
64814006	140	6	240	279	25	160	10	146	23.5	8	3/4	8.9
64816006	160	6	240	279	25	180	10	167	23.5	8	3/4	7.8
64818006	180	6	240	279	25	180	10	167	23.5	8	3/4	7.8
64820008	200	8	297.5	343	28	230	15	210	23.5	8	3/4	12.9
64822508	225	8	297.5	343	28	255	15	236	23.5	8	3/4	10.9
64825010	250	10	362	406	30	284	17	262	25	12	7/8	18.2
64828010	280	10	362	406	30	314	17	293	25	12	7/8	14.9
64831512	315	12	432	482	32	355	20	331	25	12	7/8	24.7
64835514	355	14	475	533	35	395	20	371	30	12	1	32.2
64840016	400	16	540	597	36	444	22	417	30	16	1	41.3
64845018	450	18	577.6	635	40	494	22	467	32	16	1 1/8	46.5
64850020	500	20	635	698	43	550	25	518	32	20	1 1/8	59.1
64863024	630	24	749	813	48	690	30	652	35	20	1 1/4	71.1

Split Flanges for Flared Ends

Material

Body: Spheroidal cast iron 450-10 according to ISO 1083 with FBE 300µm RAL 7000 coating.

Specifications

- Pressure rating and temperature according to ANSI 150.

Notes

According to standard:

- ANSI B16.5 class150
- AS2129/B.S 10:1962 TABLE E
- DIN 16



Catalog Number	Pipe diameter (mm)	Flange diameter (inch)	OD [mm]	WT [mm]	PCD 1 [mm]	PCD 2 [mm]	Number of bolts	Bolt hole diameter [mm]	Weight [Kg]
SFF06301	63	2"	165	20	125	114.3	4	19	2
SFF07501	75	2.5"	185.0	22	145	127	4	19	2.6
SFF09001	90	3"	200	24	160	146	4	19	3.3
SFF11001	110	4"	228.6	24	190.5	177.8	8	19	4
SFF12501	125	4"	228.6	24	190.5	177.8	8	19	3.7
SFF14001	140	6"	285	25	241.3	235	8	22	6
SFF16001	160	6"	285	25	241.3	235	8	22	5.5
SFF18001	180	6"	285	25	241.3	235	8	22	4.9

Split Flanges for PE-Xc Fittings

Material

Body: Spheroidal cast iron 450-10 according to ISO 1083 with hot deep galvanizing 85 µ coating.

Specifications

- Pressure rating and temperature according to the chosen pipe.

Notes

- Compatible with ASA150.
- Available in sizes 63-630 mm
- When order PE-Xc fitting, the split flanges will be packed separately but delivered together.
- A Prefabricated Fitting that connects to another Prefabricated Fitting will require use of special gasket.
- PE-Xc in size 450 mm requires a special stub end.



Catalog Number	Part Description	OD [mm]	WT [mm]	PCD [MM]	Number of bolts	Bolt hole diameter [mm]	Weight [Kg]
SFR006302	Split Flange 63 (2") ASA 150	152.4	19	120.7	4	19	1.4
SFR007525	Split Flange 75 (2.5") ASA 150	177.8	22	139.7	4	19	2.2
SFR009003	Split Flange 90 (3") ASA 150	190.5	24	152.4	4	19	2.6
SFR011004	Split Flange 110 (4") ASA 150	228.6	24	190.5	8	19	3.8
SFR012504	Split Flange 125 (4") ASA 150	228.6	24	190.5	8	19	3.5
SFR014006	Split Flange 140 (6") ASA 150	279.4	25	241.3	8	22	5.5
SFR016006	Split Flange 160 (6") ASA 150	279.4	25	241.3	8	22	4.9
SFR018006	Split Flange 180 (6") ASA 150	279.4	25	241.3	8	22	4.5
SFR020008	Split Flange 200 (8") ASA 150	343	29	298.5	8	22	8.2
SFR022508	Split Flange 225 (8") ASA 150	343	29	298.5	8	22	7.8
SFR025010	Split Flange 250 (10") ASA 150	406.4	30	362	12	25	11.7
SFR028010	Split Flange 280 (10") ASA 150	406.4	30	362	12	25	10.7
SFR031512	Split Flange 315 (12") ASA 150	482.6	32	431.8	12	25	16.9
SFR035514	Split Flange 355 (14") ASA 150	533.4	35	476.3	12	29	22.5
SFR040016	Split Flange 400 (16") ASA 150	597	37	539.8	16	29	29.7
SFR045018	Split Flange 450 (18") ASA 150	635	40	577.9	16	32	31.6
SFR050020	Split Flange 500 (20") ASA 150	698.5	43	635	20	32	44
SFR063024	Split Flange 630 (24") ASA 150	812.8	48	749.3	20	35	55.2

Pexgol Elbow

- The elbows are supplied with clamps and fixing elements in order to be able to supply an accurate angle. In addition this fixing elements allow for minor correction of the angle in the field if this is necessary.
- After installation it is possible to remove the clamps if required.
- Prefabricated elbows are produced from Pexgol pipes of all classes according to a proprietary process. The length of each leg of a Pexgol elbows is specified according to dimension A or dimension B in the table below. Prefabricated elbows with flared-ends are available in any length between the minimum and maximum values, dimension A. Prefabricated elbows with plain ends are available in minimum lengths according to dimension B.
- Each leg can be supplied with plain ends or with flared ends with or without flanges. and in varying length for each leg.
- For ordering please write the length A or B and describe the pipe ends.
- **For example:**
ELB16014.6 - 453D one leg 550 mm with flared end and flange ASA 150, other leg 420 mm plain end.
- The weight of the elbow is calculated by adding the A or B values of the legs, dividing them by 1,000 (to get the total length of the elbow in meters) and then multiplying by the weight of the pipe per meter according to the pipe dimensions tables.

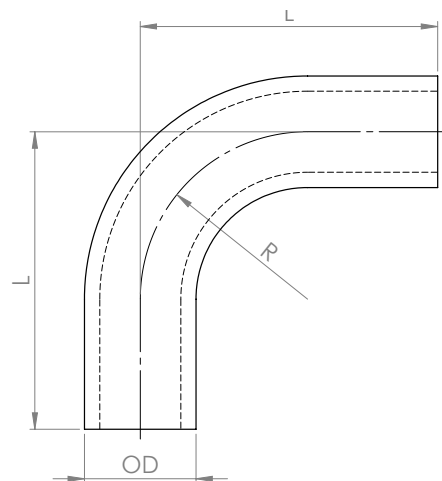
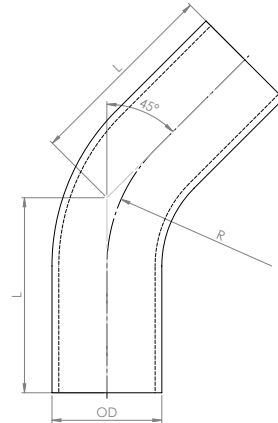

OD	Class	1.5D		3D	
		45 °	90 °	45 °	90 °
		Catalogue Number	Catalogue Number	Catalogue Number	Catalogue Number
50	15	ELB504.6-451.5D	ELB504.6-901.5D	ELB504.6-453D	ELB504.6-903D
50	19	ELB505.6-451.5D	ELB505.6-451.5D	ELB505.6-453D	ELB505.6-453D
50	24	ELB506.9-451.5D	ELB506.9-901.5D	ELB506.9-453D	ELB506.9-903D
50	30	ELB508.3-451.5D	ELB508.3-451.5D	ELB508.3-453D	ELB508.3-453D
63	15	ELB635.8-451.5D	ELB635.8-901.5D	ELB635.8-453D	ELB635.8-903D
63	19	ELB637.1-451.5D	ELB637.1-901.5D	ELB637.1-453D	ELB637.1-903D
63	24	ELB638.6-451.5D	ELB638.6-901.5D	ELB638.6-453D	ELB638.6-903D
63	30	ELB6310.5-451.5D	ELB6310.5-901.5D	ELB6310.5-453D	ELB6310.5-903D
75	15	ELB756.8-451.5D	ELB756.8-901.5D	ELB756.8-453D	ELB756.8-903D
75	19	ELB758.4-451.5D	ELB758.4-901.5D	ELB758.4-453D	ELB758.4-903D
75	24	ELB7510.3-451.5D	ELB7510.3-901.5D	ELB7510.3-453D	ELB7510.3-903D
75	30	ELB7512.5-451.5D	ELB7512.5-901.5D	ELB7512.5-453D	ELB7512.5-903D
90	15	ELB908.2-451.5D	ELB908.2-901.5D	ELB908.2-453D	ELB908.2-903D
90	19	ELB9010.1-451.5D	ELB9010.1-901.5D	ELB9010.1-453D	ELB9010.1-903D
90	24	ELB9012.3-451.5D	ELB9012.3-901.5D	ELB9012.3-453D	ELB9012.3-903D
90	30	ELB9015.0-451.5D	ELB9015.0-901.5D	ELB9015.0-453D	ELB9015.0-903D
110	15	ELB11010-451.5D	ELB11010-901.5D	ELB11010-453D	ELB11010-903D
110	19	ELB11012.3-451.5D	ELB11012.3-901.5D	ELB11012.3-453D	ELB11012.3-903D
110	24	ELB11015.1-451.5D	ELB11015.1-901.5D	ELB11015.1-453D	ELB11015.1-903D
110	30	ELB11018.3-451.5D	ELB11018.3-901.5D	ELB11018.3-453D	ELB11018.3-903D
125	15	ELB12511.4-451.5D	ELB12511.4-901.5D	ELB12511.4-453D	ELB12511.4-903D
125	19	ELB12514.1-451.5D	ELB12514.1-901.5D	ELB12514.1-453D	ELB12514.1-903D
125	24	ELB12517.1-451.5D	ELB12517.1-901.5D	ELB12517.1-453D	ELB12517.1-903D
125	30	ELB12520.8-451.5D	ELB12520.8-901.5D	ELB12520.8-453D	ELB12520.8-903D
140	15	ELB14012.7-451.5D	ELB14012.7-901.5D	ELB14012.7-453D	ELB14012.7-903D
140	19	ELB14015.7-451.5D	ELB14015.7-901.5D	ELB14015.7-453D	ELB14015.7-903D
140	24	ELB14019.2-451.5D	ELB14019.2-901.5D	ELB14019.2-453D	ELB14019.2-903D
140	30	ELB14023.3-451.5D	ELB14023.3-901.5D	ELB14023.3-453D	ELB14023.3-903D
160	15	ELB16014.6-451.5D	ELB16014.6-901.5D	ELB16014.6-453D	ELB16014.6-903D
160	19	ELB16017.9-451.5D	ELB16017.9-901.5D	ELB16017.9-453D	ELB16017.9-903D
160	24	ELB16021.9-451.5D	ELB16021.9-901.5D	ELB16021.9-453D	ELB16021.9-903D
160	30	ELB16026.6-451.5D	ELB16026.6-901.5D	ELB16026.6-453D	ELB16026.6-903D
180	15	ELB18016.3-451.5D	ELB18016.3-901.5D	ELB18016.3-453D	ELB18016.3-903D
180	19	ELB18020.1-451.5D	ELB18020.1-901.5D	ELB18020.1-453D	ELB18020.1-903D
180	24	ELB18024.6-451.5D	ELB18024.6-901.5D	ELB18024.6-453D	ELB18024.6-903D
180	30	ELB18029.9-451.5D	ELB18029.9-901.5D	ELB18029.9-453D	ELB18029.9-903D
200	15	ELB20018.1-451.5D	ELB20018.1-901.5D	ELB20018.1-453D	ELB20018.1-903D
200	19	ELB20022.4-451.5D	ELB20022.4-901.5D	ELB20022.4-453D	ELB20022.4-903D
200	24	ELB20027.4-451.5D	ELB20027.4-901.5D	ELB20027.4-453D	ELB20027.4-903D
200	30	ELB20033.2-451.5D	ELB20033.2-901.5D	ELB20033.2-453D	ELB20033.2-903D
225	15	ELB22520.4-451.5D	ELB22520.4-901.5D	ELB22520.4-453D	ELB22520.4-903D
225	19	ELB22525.0-451.5D	ELB22525.0-901.5D	ELB22525.0-453D	ELB22525.0-903D
225	24	ELB22530.8-451.5D	ELB22530.8-901.5D	ELB22530.8-453D	ELB22530.8-903D
225	30	ELB22537.4-451.5D	ELB22537.4-901.5D	ELB22537.4-453D	ELB22537.4-903D
250	15	ELB25022.7-451.5D	ELB25022.7-901.5D	ELB25022.7-453D	ELB25022.7-903D

OD	Class	1.5D		3D	
		45 °	90 °	45 °	90 °
		Catalogue Number	Catalogue Number	Catalogue Number	Catalogue Number
250	19	ELB25027.9-451.5D	ELB25027.9-901.5D	ELB25027.9-453D	ELB25027.9-903D
250	24	ELB25034.2-451.5D	ELB25034.2-901.5D	ELB25034.2-453D	ELB25034.2-903D
250	30	ELB25041.5-451.5D	ELB25041.5-901.5D	ELB25041.5-453D	ELB25041.5-903D
280	15	ELB28025.4-451.5D	ELB28025.4-901.5D	ELB28025.4-453D	ELB28025.4-903D
280	19	ELB28031.3-451.5D	ELB28031.3-901.5D	ELB28031.3-453D	ELB28031.3-903D
280	24	ELB28038.3-451.5D	ELB28038.3-901.5D	ELB28038.3-453D	ELB28038.3-903D
280	30	ELB28046.5-451.5D	ELB28046.5-901.5D	ELB28046.5-453D	ELB28046.5-903D
315	15	ELB31528.6-451.5D	ELB31528.6-901.5D	ELB31528.6-453D	ELB31528.6-903D
315	19	ELB31535.2-451.5D	ELB31535.2-901.5D	ELB31535.2-453D	ELB31535.2-903D
315	24	ELB31543.1-451.5D	ELB31543.1-901.5D	ELB31543.1-453D	ELB31543.1-903D
315	30	ELB31552.3-451.5D	ELB31552.3-901.5D	ELB31552.3-453D	ELB31552.3-903D
355	15	ELB35532.2-451.5D	ELB35532.2-901.5D	ELB35532.2-453D	ELB35532.2-903D
355	19	ELB35539.7-451.5D	ELB35539.7-901.5D	ELB35539.7-453D	ELB35539.7-903D
355	24	ELB35548.5-451.5D	ELB35548.5-901.5D	ELB35548.5-453D	ELB35548.5-903D
355	30	ELB35559.0-451.5D	ELB35559.0-901.5D	ELB35559.0-453D	ELB35559.0-903D
400	15	ELB40036.3-451.5D	ELB40036.3-901.5D	ELB40036.3-453D	ELB40036.3-903D
400	19	ELB40044.7-451.5D	ELB40044.7-901.5D	ELB40044.7-453D	ELB40044.7-903D
400	24	ELB40054.7-451.5D	ELB40054.7-901.5D	ELB40054.7-453D	ELB40054.7-903D
400	30	ELB40066.7-451.5D	ELB40066.7-901.5D	ELB40066.7-453D	ELB40066.7-903D
450	15	ELB45040.9-451.5D	ELB45040.9-901.5D	ELB45040.9-453D	ELB45040.9-903D
450	19	ELB45050.3-451.5D	ELB45050.3-901.5D	ELB45050.3-453D	ELB45050.3-903D
450	24	ELB45061.5-451.5D	ELB45061.5-901.5D	ELB45061.5-453D	ELB45061.5-903D
450	30	ELB45075.0-451.5D	ELB45075.0-901.5D	ELB45075.0-453D	ELB45075.0-903D
500	15	ELB50045.4-451.5D	ELB50045.4-901.5D	ELB50045.4-453D	ELB50045.4-903D
500	19	ELB50055.8-451.5D	ELB50055.8-901.5D	ELB50055.8-453D	ELB50055.8-903D
500	24	ELB50068.5-451.5D	ELB50068.5-901.5D	ELB50068.5-453D	ELB50068.5-903D
500	30	ELB500 83.5-451.5D	ELB500 83.5-901.5D	ELB500 83.5-453D	ELB500 83.5-903D
560	15	ELB56050.8-451.5D	ELB56050.8-901.5D	ELB56050.8-453D	ELB56050.8-903D
560	19	ELB56062.5-451.5D	ELB56062.5-901.5D	ELB56062.5-453D	ELB56062.5-903D
560	24	ELB56076.7-451.5D	ELB56076.7-901.5D	ELB56076.7-453D	ELB56076.7-903D
560	30	ELB56093.5-451.5D	ELB56093.5-901.5D	ELB56093.5-453D	ELB56093.5-903D
630	15	ELB63057.2-451.5D	ELB63057.2-901.5D	ELB63057.2-453D	ELB63057.2-903D
630	19	ELB63070.0-451.5D	ELB63070.0-901.5D	ELB63070.0-453D	ELB63070.0-903D
630	24	ELB63086.3-451.5D	ELB63086.3-901.5D	ELB63086.3-453D	ELB63086.3-903D
630	30	ELB630105-451.5D	ELB630105-901.5D	ELB630105-453D	ELB630105-903D
710	15	ELB71064.5-451.5D	ELB71064.5-901.5D	ELB71064.5-453D	ELB71064.5-903D
710	19	ELB71078.9-451.5D	ELB71078.9-901.5D	ELB71078.9-453D	ELB71078.9-903D
710	24	ELB71097.3-453D	ELB71097.3-901.5D	ELB71097.3-453D	ELB71097.3-903D
710	30	ELB710118.3-453D	ELB710118.3-901.5D	ELB710118.3-453D	ELB710118.3-903D

Pexgol Reducer

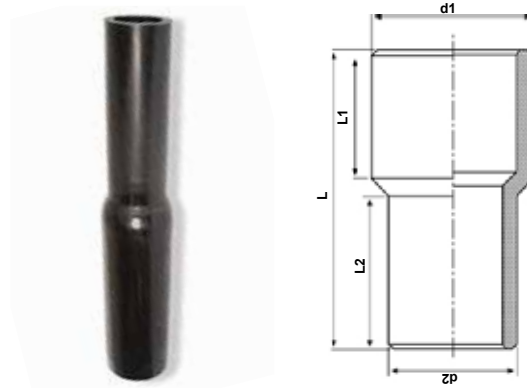

Table 145.1: Dimensions of standard Pexgol spigot reducers

Catalogue Number	Size d1 x d2 (mm)	Size L (mm)	Size L1 (mm)	Size L2 (mm)	Weight (kg) Class 10	Weight (kg) Class 15	Weight (kg) Class 24
RED75x63	75x63	405	205	175	0.20	0.3	0.43
RED90x75	90x75	420	215	180	0.34	0.49	0.7
RED90x63	90x63	420	215	175	0.35	0.49	0.71
RED110x90	110x90	580	280	270	0.55	0.79	1.14
RED110x75	110x75	580	280	255	0.56	0.8	1.16
RED110x63	110x63	580	280	240	0.57	0.81	1.17
RED125x110	125x110	620	280	280	0.73	1.04	1.48
RED125x90	125x90	620	280	270	0.78	1.12	1.59
RED140x125	140x125	700	360	290	0.98	1.38	1.98
RED140x110	140x110	700	360	280	1	1.41	2.03
RED160x140	160x140	720	355	360	1.32	1.88	2.68
RED160x125	160x125	720	355	350	1.4	2	2.85
RED160x110	160x110	720	355	340	1.43	2.04	2.9
RED180x160	180x160	580	260	255	2.1	3	4.2
RED180x140	180x140	580	260	245	1.5	2.2	3.1
RED180x125	180x125	580	260	235	1.6	2.3	3.3
RED200x160	200x160	580	260	255	2.45	3.46	4.97
RED225x200	225x200	590	250	270	3.23	4.6	6.58
RED225x180	225x180	590	260	260	3.1	4.35	6.2
RED225x160	225x160	590	260	260	3.45	4.92	7.03
RED250x225	250x225	680	330	320	4.25	6.02	8.74
RED250x200	250x200	680	330	320	4.41	6.24	9.07
RED280x250	280x250	700	340	330	5.72	8.15	15.57
RED280x225	280x225	700	300	320	5.98	8.51	16.26
RED315x280	315x280	770	340	330	7.82	11.14	18.87
RED315x250	315x250	770	340	330	8.13	11.58	19.62
RED355x315	355x315	795	350	340	10.7	15.25	23
RED355x280	355x280	795	350	340	11.31	16.12	24.3

Table 146.1: Dimensions of non-standard Pexgol spigot reducers (manufactured by special request)

Catalogue Number	Size d1 x d2 (mm)	Size L (mm)	Size L1 (mm)	Size L2 (mm)	Weight (kg) Class 10	Weight (kg) Class 15	Weight (kg) Class 24
N/A	400x355	815	355	350	15.02	21.44	28.58
N/A	400x315	815	355	350	15.72	22.43	29.91
N/A	450x400	865	275	355	21.1	30.17	36.76
N/A	450x355	865	400	355	21.96	31.4	38.26
N/A	500x450	631	302	275	28.4	40.7	43.22
N/A	500x400	659	302	249	29.66	42.51	45.14
N/A	630x500	782	340	302	55.94	79.49	67.52
N/A	630x450	809	340	275	57.87	82.24	69.85

Flange Coupler



Compatibility with international flange standards

Catalogue Number	Pipe OD (mm)	Nominal Flange size		DIN			ANSI		BSTD
		DN (mm)	In.	2632	2633	2634	125	150	
				10	16	25			
50806320	63	50	2"	V	V	V	V	V	-
50807525	75	65	2 1/2"	V	V	-	V	V	-
50809030	90	80	3"	V	V	V	V	V	-
50811040	110	100	4"	V	V	V	V	V	V
50812540	125	100	4"	V	V	V	V	V	V
50814060	140	150	6"	V	V	-	V	V	V
50816060	160	150	6"	V	V	-	V	V	V
50818060	180	150	6"	V	V	-	V	V	V
50820080	200	200	8"	V	-	-	V	V	V
50822580	225	200	8"	V	V	-	V	V	V
50825010	250	250	10"	V	V	-	V	V	-
50928010	280 ASA	-	10"	-	V	-	V	V	-
50828010	280 BS	250		-	-	-	-	-	V
50831512	315	300	12"	-	V	-	V	V	V
50835514	355	350	14"	-	-	-	V	V	V
50840016	400	400	16"	-	-	-	V	V	-
50845018	450	450	18"	-	-	-	V	V	-
50850020	500	500	20"	V	V	-	V	V	-
50863024	630	-	24"	-	-	-	V	V	-
50871028	710	-	28"	-	-	-	V	V	-

General dimensions of flanged couplings and bolts for connecting two quarters of coupler

Catalogue Number	Outside diameter of pipe (mm)	Nominal Flange size		A	C	Bolt size (in.)	Bolt length (mm)*	No. of bolts	Weight (kg)
		DN	in.						
50806320	63	50	2	165	70	3/8"	40	4	2.7
50807525	75*	65	2 1/2"	185	80	1/2"	45	4	2.5
50809030	90	80	3	208	96	1/2"	45	4	4.0
50811040	110	100	4	242	110	5/8"	45	8	6.5
50812540	125	100	4	242	110	5/8"	45	8	8
50814060	140	150	6	285	120	5/8"	50	8	10
50816060	160	150	6	285	120	5/8"	50	8	11.2
50818006	180	150	6	285	119	5/8"	50	8	12.1
50820080	200	200	8	348	130	5/8"	50	8	13.0
50822580	225	200	8	344	130	5/8"	50	8	12.4
50825010	250	250	10	410	150	5/8"	60	8	17.0
50928010	280 ASA		10	405	160	5/8"	60	8	20.0
50828010	280 BS	250		405	160	5/8"	60	8	20.0
50831512	315	300	12	475	180	3/4"	70	8	27.7
50835514	355	350	14	535	200	3/4"	70	8	40.0
50840016	400	400	16	600	215	3/4"	70	8	55.0
50845018	450	450	18	635	235	3/4"	70	8	65.0
50850020	500	500	20	715	280	3/4"	80	8	68.0
50863024	630		24	840	280	3/4"	80	8	86.0
50871028	710		28	930	320	3/4"	80	8	135.0

Notes:

- (*) For a 75 mm flange coupler a special production is required and therefore a minimum quantity order is required.

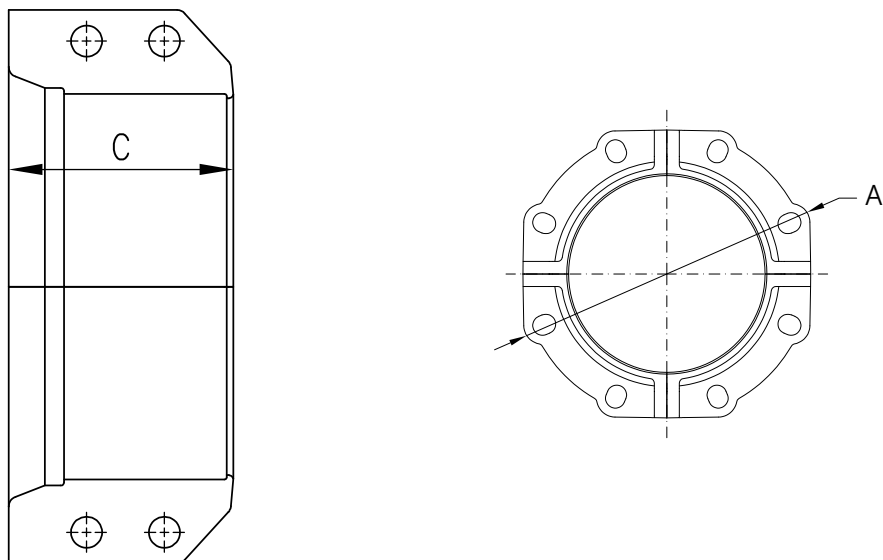

Bolts for connecting two flanged couplings

Pexgol Pipe Diameter	Flange size	Bolt size**	Bolt length (mm)**	No. of bolts	Torque N x m	Torque lb x ft
63	2"	5/8"	50	4	81	60
75	2 ½"	5/8"	50	4	81	60
90	3"	5/8"	50	4	81	60
110	4"	5/8"	50	8	81	60
125	4"	5/8"	50	8	81	60
140	6"	3/4"	60	8	136	100
160	6"	3/4"	60	8	136	100
180	6"	3/4"	60	8	136	100
200	8"	3/4"	60	8	136	100
225	8"	3/4"	60	8	136	100
250	10"	7/8"	70	12	217	160
280	10"	7/8"	70	12	217	160
315	12"	7/8"	70	12	217	160
355	14"	1"	70	12	332	245
400	16"	1"	75	16	332	245
450	18"	1-1/8"	75	16	481	355
500	20"	1-1/8"	100	20	481	355
560	22"	1-1/4"	100	20	580	427
630	24"	1-1/4"	110	20	678	500
710	28"	1-1/4"	110	28	776	572

Notes:

- Torquening the bolts should be done in a crisscross manner.
- When connecting a GP Flanged Coupler with a flared end, the torquening values of the GP Flanged Coupler are the ones that should be use.

Hydrant Connector

Catalogue Number	Nominal Diameter
85511004	110 mm
85516006	160 mm

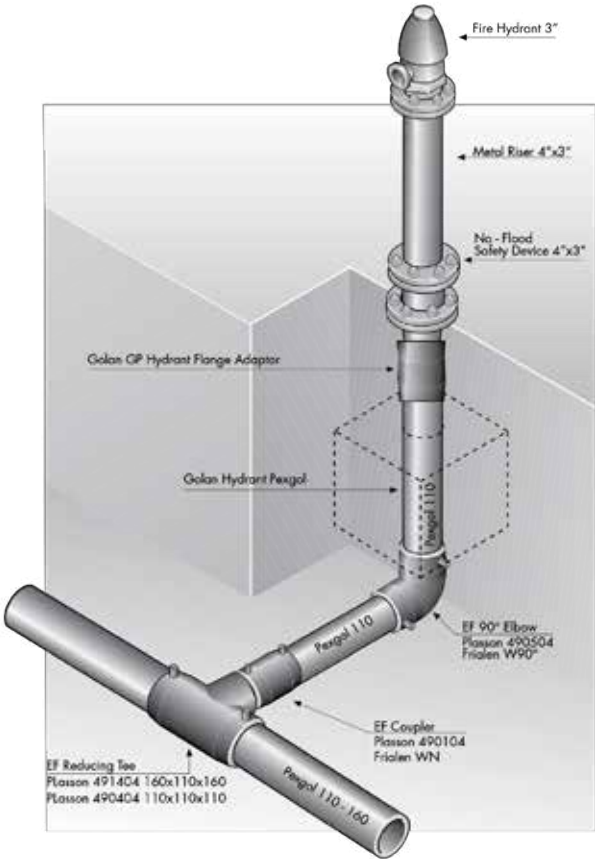

Branch-off Saddles - Flanged Outlet

Material

Body: Stainless Steel DIN 1.4401 (AISI 316)

Pressure Assisted Gasket: EPDM. Compounded for water and sewerage, meets international standards for contact with drinking water.

Lugs: Polycarbonate

Compression Beam: Casting Type 304 (ASTM-A351-CF8)

Bolts & Nuts: Type 304 stainless steel. Rolled thread and anti galling coating.

Specifications

Temperature rating: -30 °C/-22 °F to 85 °C/185 °F

Pressure Rating: Up to 12 bar

Stainless Steel Branch-off Saddles/ ASA 150 Flanged Outlet

Catalogue Number Coupler	OD (Pipe Diameter) & Flange Size	H (mm)	L (mm)	Weight (kg)
46811002	110x2"	120	225	5.5
46811003	110x3"	120	225	6.3
46812502	125x2"	120	225	7
46812503	125x3"	120	225	7
46814002	140x2"	120	300	7
46814003	140x3"	120	300	7
468916002	160x2"	120	300	7
46816003	160x3"	120	300	9
46816004	160x4"	120	300	9.5
468918002	180x2"	120	300	7
46818003	180x3"	120	300	9
46818004	180x4"	120	300	9.5
46820002	200x2"	120	375	14
46820003	200x3"	120	375	15
46820004	200x4"	120	375	15
46822502	225x2"	120	375	15
46822503	225x3"	120	375	15.6
46822504	225x4"	120	375	16
46822506	225x6"	150	375	19

Catalogue Number Coupler	OD (Pipe Diameter) & Flange Size	H (mm)	L (mm)	Weight (kg)
46825002	250x2"	120	450	16
46825003	250x3"	120	450	17
46825004	250x4"	120	450	18
46825006	250x6"	150	450	20
46928002	280x2"	120	450	17
46928003	280x3"	120	450	18
46928004	280x4"	120	450	20
46828006	280x6"	150	450	23
46831502	315x2"	120	450	18
46831503	315x3"	120	450	20
46831504	315x4"	120	450	21
46831506	315x6"	150	450	23
46831508	315x8"	150	450	28
46835502	355x2"	120	450	19
46835503	355x3"	120	450	21
46835504	355x4"	120	450	22
46835506	355x6"	150	450	25
46835508	355x8"	150	450	29
46840003	400x3"	120	525	23
46840004	400x4"	120	525	23
46840006	400x6"	150	525	26
46840008	400x8"	150	525	30
46845003	450x3"	120	525	24

2023

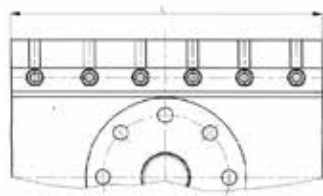
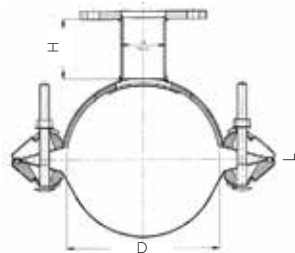

Branch-off Saddles - Female Flanged Outlet

Material

Body: Stainless Steel DIN 1.4401 (AISI 316)

Pressure Assisted Gasket: EPDM. Compounded for water and sewerage, meets international standards for contact with drinking water.

Lugs: Polycarbonate

Compression Beam: Casting Type 304 (ASTM-A351-CF8)

Bolts & Nuts: Type 304 stainless steel. Rolled thread and anti galling coating.



Specifications

Temperature rating: -30 °C/-22 °F to 85 °C/185 °F

Pressure Rating: Up to 12 bar

Catalogue Number Coupler	OD (Pipe Diameter) & Flange Size	H (mm)	L (mm)	Weight (kg)
47011020	110x2"	120	225	5.5
47011030	110x3"	120	225	6.3
47016020	160x2"	120	300	7
47016030	160x3"	120	300	9
47018020	180x2"	120	300	7
47018030	180x3"	120	300	9
47020020	200x2"	120	375	14
47020030	200x3"	120	375	15
47022520	225x2"	120	375	15
47022530	225x3"	120	375	15.6
47025020	250x2"	120	450	16
47025030	250x3"	120	450	17
47028020	280x2"	120	450	17
47028030	280x3"	120	450	18
47031520	315x2"	120	450	18
47031530	315x3"	120	450	20
47035520	355x2"	120	450	19
47035530	355x3"	120	450	21
47040030	400x3"	120	525	23
47045030	450x3"	120	525	24
47050030	500x3"	120	525	26
47063030	630x3"	120	525	29

Brass Fittings

Material

Body: Brass

Specifications

Temperature rating: 0 °C/32 °F to 90 °C/194 °F

Pressure Rating: Maximum pressure according to the pipe pressure.

Notes

- Fitting available for Pexgol pipes class 15 & 24.
- Can be provided with threaded BSPT.
- The fitting includes bolts.

Branch-Off Saddles - Male/Female Thread

Catalogue Number Coupler	Pipe	Thread
44203205	32	1/2"f
44403207	32	3/4"m
44204005	40	1/2"f
44404007	40	3/4"m
44205007	50	3/4"f
44405007	50	1"m
44206307	63	3/4"f
44206310	63	1"m
44506315	63	1 1/4" m
44506302	63	2" f
44207515	75	1 1/2" m
44507502	75	2" f
44509002	90	2" f
44511002	110	2" f
44516002	160	2" f



GP Bolt Connector - Male thread

Catalogue Number Coupler	Pipe	Class	Thread
29423210	32	15	1"
30473210	32	24	1"
29424012	40	15	1 1/4"
30474012	40	24	1 1/4"
29425015	50	15	1 1/2"
30475015	50	24	1 1/2"
29426320	63	15	2"
30476320	63	24	2"
29427525	75	15	2 1/2"
30477525	75	24	2 1/2"
29429030	90	15	3"
30479030	90	24	3"
29421104	110	15	4"
30471104	110	24	4"
294212504	125	15	4"
304712504	125	24	4"
294214005	140	15	5"
304714005	140	24	5"
29421606	160	15	6"
30471606	160	24	6"



PE-X Double Bolt Connector

Catalogue Number Coupler	Pipe	Class
91032001	32	15
91032002	32	24
91040001	40	15
91040002	40	24
91050001	50	15
91050002	50	24
91063001	63	15
91063002	63	24
91075001	75	15
91075002	75	24
91090001	90	15
91090002	90	24
91011001	110	15
91011002	110	24
91012501	125	15
91012502	125	24
91016001	160	15
91016002	160	24



TEE Female DZR Brass

Catalogue Number	Catalogue Number DZR Brass	Thread (in.)
42250511	-	0.50
42250711	-	0.75
-	42251011	1.00
-	42231211	1.25
-	42231511	1.50
-	42232011	2.00
-	42232511	2.50
-	42233011	3.00
-	42234011	4.00



Bushing DZR Brass

Catalogue Number	Catalogue Number DZR Brass	Thread (in.)
53320507		$\frac{3}{4}$ " x $\frac{1}{2}$ "
-	53320510	1" x $\frac{1}{2}$ "
-	53320710	1" x $\frac{3}{4}$ "
-	53310712	1 $\frac{1}{4}$ " x $\frac{3}{4}$ "
-	53310715	1 $\frac{1}{2}$ " x $\frac{3}{4}$ "
-	53331012	1 $\frac{1}{4}$ " x 1"
-	53331015	1 $\frac{1}{2}$ " x 1"
-	53331215	1 $\frac{1}{2}$ " x 1 $\frac{1}{4}$ "
-	53330720	2" x $\frac{3}{4}$ "
-	53331020	2" x 1"
-	53331220	2" x 1 $\frac{1}{4}$ "
-	53331520	2" x 1 $\frac{1}{2}$ "
-	53332512	2 $\frac{1}{2}$ " x 1 $\frac{1}{4}$ "
-	53331525	2 $\frac{1}{2}$ " x 1 $\frac{1}{2}$ "
-	53332025	2 $\frac{1}{2}$ " x 2"
-	53332030	3" x 2"
-	53333025	3" x 2 $\frac{1}{2}$ "
-	53334020	4" x 2"
-	53334025	4" x 2 $\frac{1}{2}$ "
-	53334030	4" x 3"



Female Coupler DZR Brass

Catalogue Number	Catalogue Number DZR Brass	Thread (in.)
57220511	-	0.50
57220711	-	0.75
-	57221011	1.00
-	57231211	1.25
-	57231511	1.50
-	57232011	2.00
-	57232015	2.50
-	57233011	3.00
-	57234011	4.00



Nipple DZR Brass

Catalogue Number	Catalog Number DZR brass	Thread (in.)
55410511	-	1/2"
55410711	-	3/4"
-	55431011	1"
-	55431211	1 1/4"
-	55431511	1 1/2"
-	55432011	2"
-	55432511	2 1/2"
-	55433011	3"
-	55434011	4"



Reducing Nipple DZR Brass

Catalogue Number	Catalog Number DZR brass	Thread (in.)
27420705	-	3/4" x 1/2"
-	27420710	1" x 3/4"
-	27411215	1 1/2" x 1 1/4"
-	27431220	2" x 1 1/4"
-	27431520	2" x 1 1/2"
-	27431525	2 1/2" x 1 1/2"
-	27432025	2 1/2" x 2"
-	27433020	3" x 2"
-	27434030	4" x 3"



Male/Female Elbow 90° (Material Brass CuZn40Pb2/DZR Brass)

Catalogue Number Stand. brass	Catalogue Number DZR brass	Size
-	32310511	1/2"
-	32310711	3/4"
-	32331011	1"
-	32331211	1 1/4"
-	32331511	1 1/2"
-	32332011	2"
-	32332511	2 1/2"
-	32333011	3"



Female Elbow 90°

Catalogue Number Stand. brass	Catalogue Number DZR brass	Size
32230511	-	1/2"
32230711	-	3/4"
-	32231011	1"
-	32231211	1 1/3"
-	32231511	1 1/2"
-	32232011	2"
-	32232511	2 1/2"
-	32233011	3"
-	32234011	4"



GP Bolt Connector Stainless Steel

Material

Body: Stainless Steel 316 L

Specifications

Temperature rating: -50°C/-58°F to 90°C/194°F

Pressure Rating: Maximum pressure according to the pipe pressure.

Notes

- Fitting available for Pexgol pipes class 15 & 24.
- Can be provided with threaded NPT or BSPT.
- The fitting includes bolts.



Catalogue Number	OD (Pipe Diameter)	Class	Thread
29426320-SS	63	15	2"
30476320-SS	63	24	2"
29429030-SS	90	15	3"
30479030-SS	90	24	3"
29421104-SS	110	15	4"
30471104-SS	110	24	4"
29421606-SS	160	15	6"
30471606-SS	160	24	6"
294222508	225	15	8"
304722508	225	24	8"

Fixpoint Clamps



Catalogue Number	Pipe Diameter	L (mm)	W (mm)
66206302	63	240	40
66207525	75	252	40
66209003	90	266	40
66211004	110	286	50
66212505	125	294	50
66214006	140	308	50
66216006	160	329	50
66218006	180	349	50
66220008	200	372	60
66222508	225	398	80
66225010	250	422	80
66228010	280	453	80
66231512	315	489	80
66235514	355	529	100
66240016	400	574	100
66245018	450	624	100
66250020	500	674	100
66256022	560	734	100
66263024	630	804	100
66271028	710	925	100

Fixpoint Bridge

Material

Body: Carbon Steel with internal gripping teeth made of 316L stainless steel.

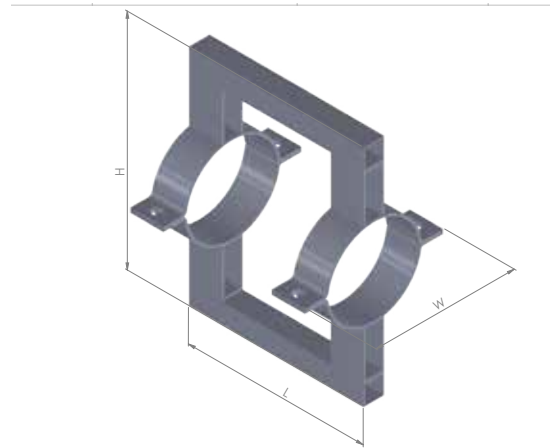

Catalogue Number	Pipe Diameter	L (mm)	H (mm)	W (mm)	Clamp width	Bolt size
301063	63	260	290	231	40	1/2"
301075	75	270	300	242	40	1/2"
301090	90	320	350	257	40	1/2"
301110	110	360	380	278	50	5/8"
301125	125	360	380	294	50	5/8"
301140	140	380	480	308	50	5/8"
301160	160	380	480	330	50	5/8"
301180	180	400	480	350	50	3/4"
301200	200	420	480	372	60	3/4"
301225	225	460	500	398	80	3/4"
301250	250	510	560	423	80	3/4"
301280	280	520	560	453	80	3/4"
301315	315	580	650	490	80	3/4"
301355	355	650	700	530	100	1"
301400	400	750	750	574	100	1"
301450	450	750	800	624	100	1"
301500	500	800	850	674	100	1"
301560	560	800	900	734	100	1"
301630	630	800	950	804	100	1"

PE-X Lined Fittings

Material

Body: St 37.0-DIN 1629

Lining: PE-X ASTM D1998-04

Available on request

- Teflon lining.
- One or two loose flanges.
- ANSI B16.5 Class 300 flanges.
- Stainless steel body and flanges 304/316.
- Different lengths (L).

Notes

- Lined pipes and fittings made with PE-X inner coating can be manufactured in diameters from 2" and up to 24".
- Lined pipes and fittings made with Teflon inner coating can be manufactured in diameters from 1" and up to 24".
- For lined pipes or fittings in lower/higher diameters please consult with Golan.

Lined Concentric Reducer

Catalogue Number	DN (inches)	DN2 (inches)	L (mm)	Pex lining thickness	Weight (kg)
Pex-LCR-15032-25	1 ¼"	1"	114	3.0	3.0
Pex-LCR-15038-19	1 ½"	¾"	114	X 3.0	3.1
Pex-LCR-15038-25		1"			3.3
Pex-LCR-15050-25	2"	1"	127	3.0	4.1
Pex-LCR-15050-38		1 ½"			4.8
Pex-LCR-15062-25	2 ½"	1"	140	3.0	5.8
Pex-LCR-15062-50		2"			6.9
Pex-LCR-15080-25	3"	1"	152	4.0 / 3	6.7
Pex-LCR-15080-38		1 ½"			6.2
Pex-LCR-15080-50		2"			6.9
Pex-LCR-150100-25	4"	1"	178	4.0 / 3	9.9
Pex-LCR-150100-38		1 ½"			9.3
Pex-LCR-150100-50		2"			9.8
Pex-LCR-150100-80		3"			12.4
Pex-LCR-150125-80	5"	3"	203	4.5 / 3.5	12.7
Pex-LCR-150125-100		4"			15.0
Pex-LCR-150150-25	6"	1"	229	4.5 / 3.0	18.9
Pex-LCR-150150-50		2"			19.9
Pex-LCR-150150-80		3"			17.4
Pex-LCR-150150-100		4"			18.3
Pex-LCR-150200-100	8"	4"	279	6.0	22.0
Pex-LCR-150200-150		6"			25.3
Pex-LCR-150250-100	10"	4"	305	6.0	33.0
Pex-LCR-150250-150		6"			37.5
Pex-LCR-150250-200		8"			44.7
Pex-LCR-150300-150	12"	6"	356	7.0	45.9
Pex-LCR-150300-200		8"			47.8
Pex-LCR-150300-250		10"			52.5
Pex-LCR-150350-200	14"	8"	406	7.0	69.0
Pex-LCR-150350-250		10"			73.5
Pex-LCR-150350-300		12"			80.0
Pex-LCR-150400-250	16"	10"	457	7.0	98.0
Pex-LCR-150400-300		12"			105.0
Pex-LCR-150400-350		14"			115.0
Pex-LCR-150450-300	18"	12"	483	7.0	135.0
Pex-LCR-150450-350		14"			148.0
Pex-LCR-150450-400		16"			157.0
Pex-LCR-150500-300	20"	12"	508	7.0	185.0
Pex-LCR-150500-350		14"			198.0
Pex-LCR-150500-400		16"			210.0
Pex-LCR-150500-450		18"			218.0
Pex-LCR-150600-400	24"	16"	610	7.0	272.0
Pex-LCR-150600-450		18"			282.0
Pex-LCR-150600-500		20"			291.0

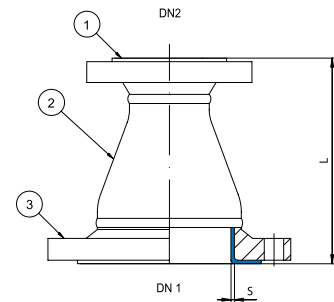

Lined Eccentric Reducer

Catalogue Number	DN (inches)	DN2 (inches)	L (mm)	Pex lining thickness	Weight (kg)
Pex-LECR-15038-25	1 ½"	1"	114	3.0	3.0
Pex-LECR-15050-25	2"	1"	127	3.0	4.0
Pex-LECR-15050-38		1 ½"			4.3
Pex-LECR-15080-25	3"	1"	152	4.0 / 3	6.7
Pex-LECR-15080-38		1 ½"			6.2
Pex-LECR-15080-50		2"			6.9
Pex-LECR-150100-38	4"	1 ½"	178	4.5 / 3.5	9.3
Pex-LECR-150100-50		2"			9.8
Pex-LECR-150100-80		3"			12.4
Pex-LECR-150150-50	6"	2"	229	5.0 / 4.0	15.6
Pex-LECR-150150-80		3"			17.0
Pex-LECR-150150-100		4"			18.7
Pex-LECR-150200-100	8"	4"	279	6.0	22.0
Pex-LECR-150200-150		6"			28.0
Pex-LECR-150250-100		4"			33.0
Pex-LECR-150250-150	10"	6"	305	6.0	37.5
Pex-LECR-150250-200		8"			44.7
Pex-LECR-150300-150	12"	6"	356	7.0	45.9
Pex-LECR-150300-200		8"			47.8
Pex-LECR-150300-250		10"			52.5
Pex-LECR-150350-200	14"	8"	406	7.0	69.0
Pex-LECR-150350-250		10"			73.5
Pex-LECR-150350-300		12"			80.0
Pex-LECR-150400-250	16"	10"	457	7.0	98.0
Pex-LECR-150400-300		12"			105.0
Pex-LECR-150400-350		14"			115.0
Pex-LECR-150450-300	18"	12"	483	7.0	135.0
Pex-LECR-150450-350		14"			148.0
Pex-LECR-150450-400		16"			157.0
Pex-LECR-150500-300	20"	12"	508	7.0	185.0
Pex-LECR-150500-350		14"			198.0
Pex-LECR-150500-400		16"			210.0
Pex-LECR-150500-450		18"			218.0
Pex-LECR-150600-500	24"	20"	610	7.0	291.0

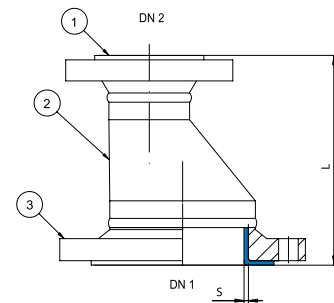

Lined Elbows 90°
ANSI B16.5 - Class 150#

Catalogue Number	DN (inches)	L (mm)	Pex lining thickness	Weight (kg)
Pex-LE90-15025	1"	89	3	3.1
Pex-LE90-15032	1 ¼"	95	3	4
Pex-LE90-15038	1 ½"	102	3	4.5
Pex-LE90-15050	2"	114	3.5	6.5
Pex-LE90-15063	2 ½"	127	3.5	9
Pex-LE90-15080	3"	140	4	12
Pex-LE90-150100	4"	165	4	19
Pex-LE90-150125	5"	190	4	22
Pex-LE90-150150	6"	203	6	34
Pex-LE90-150200	8"	229	6	57
Pex-LE90-150250	10"	279	6	82
Pex-LE90-150300	12"	305	7	115
Pex-LE90-150350	14"	546	7	150
Pex-LE90-150400	16"	610	7	192
Pex-LE90-150450	18"	673	7	225
Pex-LE90-150500	20"	737	7	280
Pex-LE90-150600	24"	864	7	395

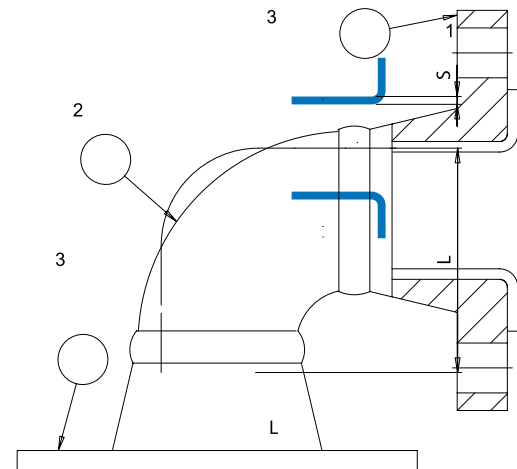

Lined Elbows 45°
ANSI B16.5 - Class 150#

Catalogue Number	DN (inches)	L (mm)	Pex lining thickness	Weight (kg)
Pex-LE45-15025	1"	45	3	3
Pex-LE45-15032	1 ¼"	51	3	4
Pex-LE45-15038	1 ½"	57	3	6
Pex-LE45-15050	2"	64	3.5	9
Pex-LE45-15063	2 ½"	76	3.5	13
Pex-LE45-15080	3"	76	4	15
Pex-LE45-150100	4"	102	4	20
Pex-LE45-150125	5"	114	4	26
Pex-LE45-150150	6"	127	6	33
Pex-LE45-150200	8"	140	6	54
Pex-LE45-150250	10"	165	6	75
Pex-LE45-150300	12"	190	7	110
Pex-LE45-150350	14"	190	7	117
Pex-LE45-150400	16"	203	7	145
Pex-LE45-150450	18"	216	7	165
Pex-LE45-150500	20"	241	7	210
Pex-LE45-150600	24"	279	7	290

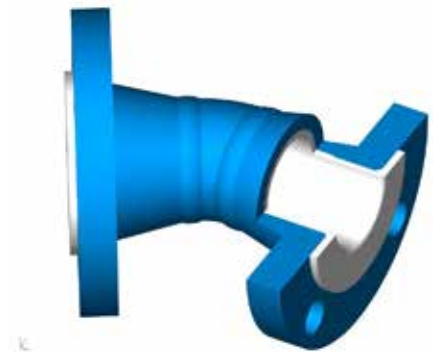

Lined Elbows 60°
ANSI B16.5 - Class 150#

Catalogue Number	DN (inches)	L (mm)	Pex lining thickness	Weight (kg)
Pex-LE60-15025	1"	45	3	2.7
Pex-LE60-15032	1 ¼"	51	3	3.6
Pex-LE60-15038	1 ½"	57	3	5.4
Pex-LE60-15050	2"	64	3.5	8.1
Pex-LE60-15063	2 ½"	76	3.5	11.7
Pex-LE60-15080	3"	76	4	13.5
Pex-LE60-150100	4"	102	4	18
Pex-LE60-150125	5"	114	4	20.5
Pex-LE60-150150	6"	127	6	26.1
Pex-LE60-150200	8"	140	6	42.7
Pex-LE60-150250	10"	165	6	59.3
Pex-LE60-150300	12"	190	7	86.9
Pex-LE60-150350	14"	190	7	92.4
Pex-LE60-150400	16"	203	7	114.6
Pex-LE60-150450	18"	216	7	130.4
Pex-LE60-150500	20"	241	7	165.9
Pex-LE60-150600	24"	279	7	229.1



Lined Elbows 30°
ANSI B16.5 - Class 150#

Catalogue Number	DN (inches)	L (mm)	Pex lining thickness	Weight (kg)
Pex-LE30-15025	1"	45	3	2.7
Pex-LE30-15032	1 ¼"	51	3	3.6
Pex-LE30-15038	1 ½"	57	3	5.4
Pex-LE30-15050	2"	64	3.5	8.1
Pex-LE30-15063	2 ½"	76	3.5	11.7
Pex-LE30-15080	3"	76	4	13.5
Pex-LE30-150100	4"	102	4	16
Pex-LE30-150125	5"	114	4	20.8
Pex-LE30-150150	6"	127	6	26.4
Pex-LE30-150200	8"	140	6	43.2
Pex-LE30-150250	10"	165	6	56.3
Pex-LE30-150300	12"	190	7	82.5
Pex-LE30-150350	14"	190	7	87.8
Pex-LE30-150400	16"	203	7	108.8
Pex-LE30-150450	18"	216	7	123.8
Pex-LE30-150500	20"	241	7	157.5
Pex-LE30-150600	24"	279	7	217.5



Lined Equal Cross

Catalogue Number	DN (inches)	L (mm)	PE-X lining thickness	Weight (kg)
Pex-LC-15025	1"	89	3.0	5.5
Pex-LC-15032	1 1/4"	95	3.0	6.5
Pex-LC-15038	1 1/2"	102	3.0	8.2
Pex-LC-15050	2"	114	3.5	13.6
Pex-LC-15063	2 1/2"	127	3.5	16.5
Pex-LC-15080	3"	140	4.0	23.6
Pex-LC-150100	4"	165	4.5	33.0
Pex-LC-150125	5"	190	4.5	43.0
Pex-LC-150150	6"	203	6.0	52.3
Pex-LC-150200	8"	229	6.0	86.3
Pex-LC-150250	10"	279	6.0	124.0
Pex-LC-150300	12"	305	7.0	169.0
Pex-LC-150350	14"	356	7.0	300.0
Pex-LC-150400	16"	381	7.0	372.0
Pex-LC-150450	18"	419	7.0	427.0
Pex-LC-150500	20"	457	7.0	547.0
Pex-LC-150600	24"	559	7.0	713.0

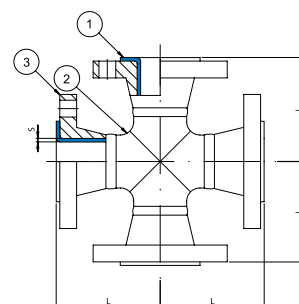

Lined Equal Tee

Catalogue Number	DN (inches)	L (mm)	Pex lining thickness	Weight (kg)
Pex-LET-15025	1"	89	3,0	3,5
Pex-LET-15032	1 1/4"	95	3,0	4,6
Pex-LET-15038	1 1/2"	102	3,0	6,5
Pex-LET-15050	2"	114	3,5	10,0
Pex-LET-15063	2 1/2"	127	3,5	13,7
Pex-LET-15080	3"	140	4,0	21,0
Pex-LET-150100	4"	165	4,5	36,0
Pex-LET-150125	5"	190	4,5	43,0
Pex-LET-150150	6"	203	6,0	49,0
Pex-LET-150200	8"	229	6,0	75,0
Pex-LET-150250	10"	279	6,0	113,0
Pex-LET-150300	12"	305	7,0	153,0
Pex-LET-150350	14"	356	7,0	197,0
Pex-LET-150400	16"	381	7,0	263,0
Pex-LET-150450	18"	419	7,0	303,0
LET-150500	20"	457	7,0	330,0
LET-150600	24"	559	7,0	397,0

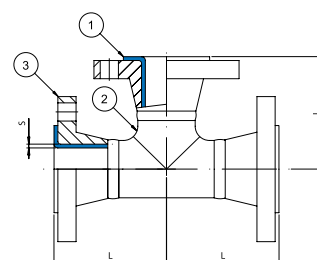

Lined Instrument Tee

Catalogue Number	DN (inches)	DN2 (inches)	L (mm)	Pex lining thickness	Weight (kg)
Pex-LIT-15025-25	1"	1"	50	4.0	2.2
Pex-LIT-15038-25	1 ½"	1"		4.0	2.8
Pex-LIT-15038-38		1 ½"	75		4.4
Pex-LIT-15050-25	2"	1"	50	4.0	3.6
Pex-LIT-15050-38		1 ½"	75		6.2
Pex-LIT-15050-50		2"	90		8.1
Pex-LIT-15062-25	2 ½"	1"	50	4.0	3.9
Pex-LIT-15062-38		1 ½"	75		7.2
Pex-LIT-15062-50		2"	90		9.8
Pex-LIT-15080-25	3"	1"	50	4.0	4.7
Pex-LIT-15080-38		1 ½"	75		8.3
Pex-LIT-15080-50		2"	90		12.6
Pex-LIT-150100-25	4"	1"	50	4.0	5.9
Pex-LIT-150100-38		1 ½"	75		8.9
Pex-LIT-150100-50		2"	90		16.0
Pex-LIT-150100-80		3"	130		24.5
Pex-LIT-150150-25	6"	1"	50	4.0	8.2
Pex-LIT-150150-38		1 ½"	75		14.7
Pex-LIT-150150-50		2"	90		21.8
Pex-LIT-150150-80		3"	130		30.1
Pex-LIT-150200-25	8"	1"	50	4.0	10.5
Pex-LIT-150200-38		1 ½"	75		17.8
Pex-LIT-150200-50		2"	90		23.3
Pex-LIT-150200-80		3"	130		33.3
Pex-LIT-150100-25	10"	1"	50	4.0	13.7
Pex-LIT-150100-38		1 ½"	75		23.3
Pex-LIT-150100-50		2"	90		26.0
Pex-LIT-150100-80		3"	160		36.7
Pex-LIT-150100-25	12"	1"	50	4.0	43.0
Pex-LIT-150100-38		1 ½"	75		55.5
Pex-LIT-150100-50		2"	90		62.0
Pex-LIT-150100-80		3"	160		69.0
Pex-LIT-150100-25	14"	1"	50	4.0	53.1
Pex-LIT-150100-38		1 ½"	75		66.5
Pex-LIT-150100-50		2"	90		73.7
Pex-LIT-150100-80		3"	160		103.0
Pex-LIT-150100-25	16"	1"	90	4.0	59.0
Pex-LIT-150100-38		1 ½"	110		74.0
Pex-LIT-150100-50		2"	120		83.0
Pex-LIT-150100-80		3"	160		116.7
Pex-LIT-150100-25	18"	1"	90	4.0	68.5
Pex-LIT-150100-38		1 ½"	110		90.5
Pex-LIT-150100-50		2"	120		93.7
Pex-LIT-150100-80		3"	160		129.7
Pex-LIT-150100-19	20"		90	4.0	X
Pex-LIT-150100-25		1"			72.0
Pex-LIT-150100-38		1 ½"	110		89.7
Pex-LIT-150100-50		2"	120		100.0
Pex-LIT-150100-80		3"	160		137.0
Pex-LIT-150100-25	24"	1"	90	4.0	79.1
Pex-LIT-150100-38		1 ½"	110		94.5
Pex-LIT-150100-50		2"	120		107.5
Pex-LIT-150100-80		3"	160		150.0

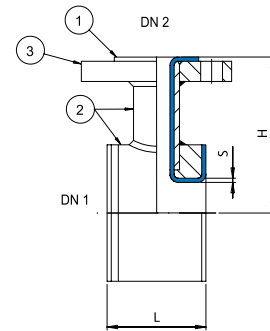

Lined Lateral Tee

Catalogue Number	DN (inches)	L (mm)	L1 (mm)	PE-X lining thickness	Weight (kg)
Pex-LLT-15025	1"	146	45	3.0	7.0
Pex-LLT-15038	1 1/2"	178	51	3.0	9.0
Pex-LLT-15050	2"	203	64	3.5	19.5
Pex-LLT-15080	3"	254	76	4.0	36.0
Pex-LLT-150100	4"	305	76	4.5	53.0
Pex-LLT-150150	6"	368	89	6.0	80.0
Pex-LLT-150200	8"	445	115	6.0	13.0

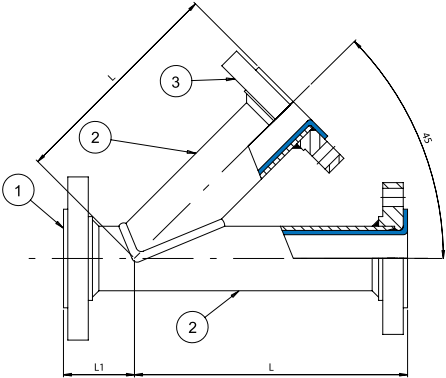

Lined Reducing Tee

Catalogue Number	DN (inches)	DN2 (inches)	L (mm)	Pex lining thickness	Weight (kg)
Pex-LRT-15032-19	1 ¼"	1 ¼"	95	x	5.3
Pex-LRT-15032-25		3.0		5.5	
Pex-LRT-15062-19	2 ½"	2 ½"	127	x	5.3
Pex-LRT-15062-25		3.0		5.5	
Pex-LRT-150100-25	5"	1"	190	4.5 / 3	19.0
Pex-LRT-150100-38		1 ½"			19.8
Pex-LRT-150100-50		2"			21.5
Pex-LRT-150100-80		3"			23.5
Pex-LRT-15038-19		¾"			102
Pex-LRT-15038-25	1 ½"	1"	3.0	5.5	
Pex-LRT-15050-25	2"	1"	114	3.0	7.9
Pex-LRT-15050-38		1 ½"			9.4
Pex-LRT-15080-25	3"	1"	140	4.0 / 3	13.8
Pex-LRT-15080-38		1 ½"			14.0
Pex-LRT-15080-50		2"			15.0
Pex-LRT-150100-25		1"			19.0
Pex-LRT-150100-38	4"	1 ½"	165	4.5 / 3	19.8
Pex-LRT-150100-50		2"			21.5
Pex-LRT-150100-80		3"			23.5
Pex-LRT-150150-25		1"			28.2
Pex-LRT-150150-38	6"	1 ½"	203	4.5 / 3	30.7
Pex-LRT-150150-50		2"			32.0
Pex-LRT-150150-80		3"			35.2
Pex-LRT-150150-100		4"			37.0
Pex-LRT-150200-25	8"	1"	229	6.0 / 3	42.5
Pex-LRT-150200-38		1 ½"			45.6
Pex-LRT-150200-50		2"			47.0
Pex-LRT-150200-80		3"			54.0
Pex-LRT-150200-100		4"			57.0
Pex-LRT-150200-150		6"			63.0
Pex-LRT-150250-25	10"	1"	280	6.0 / 3	64.6
Pex-LRT-150250-38		1 ½"			66.3
Pex-LRT-150250-50		2"			68.3
Pex-LRT-150250-80		3"			75.3
Pex-LRT-150250-100		4"			79.3
Pex-LRT-150250-150		6"			83.0
Pex-LRT-150250-200	8"	94.0			
Pex-LRT-150300-25	12"	1"	305	6.0 / 3	127.0
Pex-LRT-150300-38		1 ½"			133.0
Pex-LRT-150300-50		2"			136.0
Pex-LRT-150300-80		3"			146.0
Pex-LRT-150300-100		4"		152.0	
Pex-LRT-150300-150		6"		165.0	
Pex-LRT-150300-200		8"		219.0	
Pex-LRT-150300-250		10"		223.0	

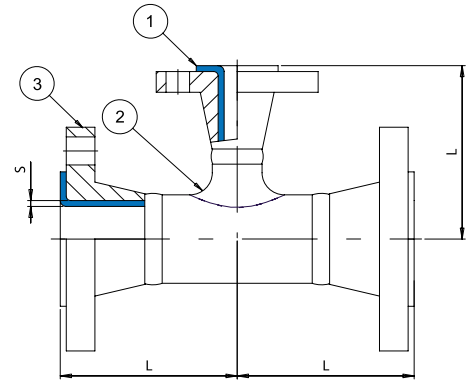

Pex-LRT-150350-25		1"			169.0		
Pex-LRT-150350-38		1 ½"			173.0		
Pex-LRT-150350-38		2"		6.0/3	175.0		
Pex-LRT-150350-50		3"			186.0		
Pex-LRT-150350-80	14"	4"	356		191.0		
Pex-LRT-150350-100		6"			204.0		
Pex-LRT-150350-150		8"		6.0	293.0		
Pex-LRT-150350-200		10"			299.0		
Pex-LRT-150350-300		12"		7.0	307.0		
Pex-LRT-150400-25	16"	1"	305	6.0 / 3	227.0		
Pex-LRT-150400-38		1 ½"			231.0		
Pex-LRT-150400-50		2"			233.0		
Pex-LRT-150400-80		3"			244.0		
Pex-LRT-150400-100		4"		250.0			
Pex-LRT-150400-150		6"		263.0			
Pex-LRT-150400-200		8"		291.0			
Pex-LRT-150400-250		10"		355.0			
Pex-LRT-150400-300		12"		359.0			
Pex-LRT-150400-350		14"		373.0			
Pex-LRT-150450-25		18"		1"	419	6.0 / 3	303.0
Pex-LRT-150450-38				1 ½"			307.0
Pex-LRT-150450-50				2"			309.0
Pex-LRT-150450-80				3"			319.0
Pex-LRT-150450-100	4"		323.0				
Pex-LRT-150450-150	6"		338.0				
Pex-LRT-150450-200	8"		372.0				
Pex-LRT-150450-250	10"		443.0				
Pex-LRT-150450-300	12"		455.0				
Pex-LRT-150450-350	14"		465.0				
Pex-LRT-150450-400	16"		473.0				
Pex-LRT-150500-25	20"		1"	457		6.0 / 3	279.0
Pex-LRT-150500-38			1 ½"				283.0
Pex-LRT-150500-50			2"				286.0
Pex-LRT-150500-80		3"	294.0				
Pex-LRT-150500-100		4"	299.0				
Pex-LRT-150500-150		6"	313.0				
Pex-LRT-150500-200		8"	343.0				
Pex-LRT-150500-250		10"	413.0				
Pex-LRT-150500-300		12"	421.0				
Pex-LRT-150500-350		14"	429.0				
Pex-LRT-150500-400		16"	439.0				
Pex-LRT-150500-450		18"	447.0				
Pex-LRT-150600-25		24"	1"		500	6.0 / 3	363.0
Pex-LRT-150600-38			1 ½"				367.0
Pex-LRT-150600-500	2"		370.0				
Pex-LRT-150600-80	3"		377.0				
Pex-LRT-150600-100	4"		383.0				
Pex-LRT-150600-150	6"		396.0				
Pex-LRT-150600-200	8"		427.0				
Pex-LRT-150600-250	10"		533.0				
Pex-LRT-150600-300	12"		543.0				
Pex-LRT-150600-350	14"		553.0				
Pex-LRT-150600-400	16"		567.0				
Pex-LRT-150600-450	18"		577.0				
Pex-LRT-150600-500	20"		589.0				

Solid and Lined Spacers

Catalogue Number	DN (in)	L (mm)
Pex-SPC-15025	1"	55
Pex-SPC-15032	1 1/4"	68
Pex-SPC-15038	1 1/2"	75
Pex-SPC-15050	2"	95
Pex-SPC-15062	2 1/2"	108
Pex-SPC-15080	3"	130
Pex-SPC-150100	4"	162
Pex-SPC-150125	5"	190
Pex-SPC-150150	6"	218
Pex-SPC-150200	8"	273
Pex-SPC-150250	10"	336
Pex-SPC-150300	12"	406
Pex-SPC-150350	14"	447
Pex-SPC-150400	16"	511
Pex-SPC-150450	18"	546
Pex-SPC-150500	20"	603
Pex-SPC-150600	24"	714

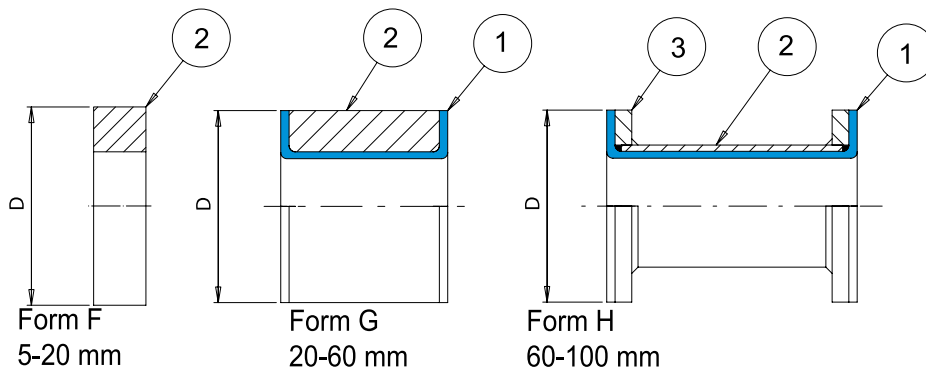

Lined Swing Check Valve

R	B	M	A	C	L	DN
50	43	26	140	100	62	65
80	46	45	170	135	65	85
100	52	65	208	170	65	55
150	56	104	270	220	65	70
200	60	145	320	275	65	90
250	68	185	400	335	65	70
300	78	230	470	405	65	95
350	78	252	510	445	65	95
400	102	300	575	510	65	95

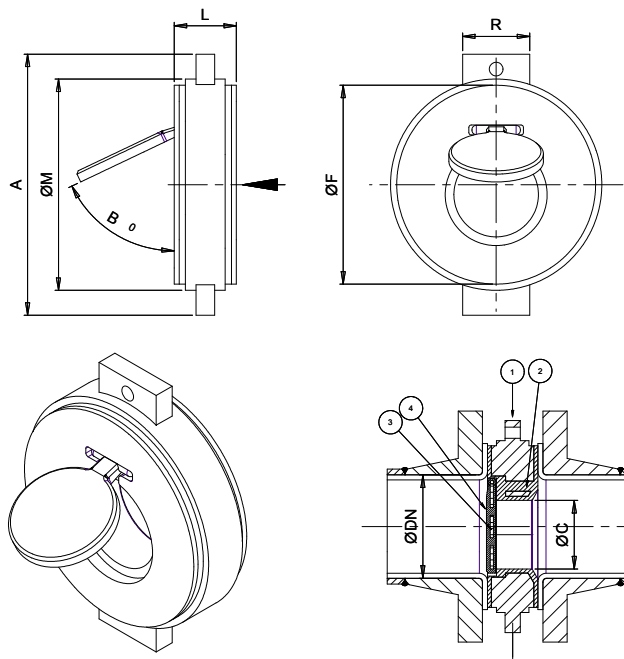

Mechanical Double Connector



Material

Body: Electro Galvanized Carbon Steel 1117

Specifications

Pressure & temperature rating:

- Sizes 63-280 mm are suitable up to class 30
- Size 315 mm is suitable up to class 24

Notes

- Connects pipe with pipe.
- EPDM gasket.

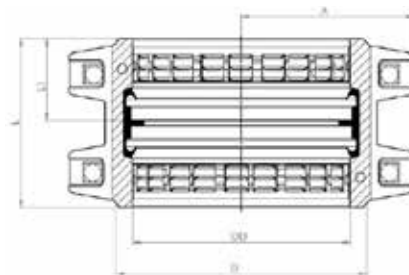

Catalogue Number	OD (Pipe Diameter)	L (mm)	L1 (mm)	D (mm)	A (mm)	W (kg)
MSF5080063	63	140	68	92	78.6	4.05
MSF5080090	90	140	68	119	92.2	5.04
MSF5080110	110	140	68	139	102.1	5.96
MSF5080160	160	156	75.5	139	140.3	11.65
MSF5080200	200	156	75.5	233	158.8	13.27
MSF5080225	225	160	75.5	258	171	15.45



PEXGO
X-LINKED PIPING SOLUTIONS

Disclaimer:

- The Engineering guide contains technical information and recommendations for the selection of products for a specific application, installing and testing them.
- All our technical information consist of the most up to date information that we have regarding our products and solutions. As such, they are subject to constant assessment, modifications and updating .
- The technical information is presented on a Bona-Fida base, for assisting the end user to gain the maximum advantage from our products.
- When using any Technical information contained here, the end user should note that the Technical data are not binding. They neither constitute expressly warranted characteristics nor guaranteed properties nor a guaranteed Lifetime durability.



www.pexgol.com

2023 © Copyright Pexgol

Pexgol PE-Xa Pipes

Pexgol PE-Xa cross-linked polyethylene line pipe has many features that make it an excellent, cost-effective alternative to other pipe materials:

- Excellent chemical and corrosion resistance (chemical agents, slurries, toxic materials, radioactive materials).
- Reduced installation costs with long-length coils/spools.
- Improved flow capacity due to smooth interior surface.
- High resistance to abrasion and UV exposure.
- Wide working temperature range.

PEXGOL
X-LINKED PIPING SOLUTIONS

Pexgol | Golan Plastic Products Ltd.
Kibbutz Shaar HaGolan, 15145, Israel

T. +972-77-9021040

F. +972-77-9021010

contact@pexgol.com

www.pexgol.com



SCAN ME